

COUNCIL MEETING AGENDA

Casper City Council
City Hall, Council Chambers
Tuesday, July 7, 2020, 6:00 p.m.



COUNCIL POLICY PUBLIC STATEMENTS

- I. Members of the Public Wishing to Speak to an Item Already on the Agenda, Other Than a Public Hearing, or Second or Third Reading Ordinance, Must Submit a Request to the City Clerk's Office by 12:00 Noon on the Monday Immediately Preceding the Council Meeting, or May Speak During the Communications From Persons Present.
- II. When Speaking to the City Council Please:
 - Clearly State Your Name and Address.
 - Direct all questions/comments to the Mayor and only the Mayor.
 - No personal attacks on staff or Council.
 - Speak to the City Council with Civility and Decorum.
- III. The City Council Will Not Respond to Any Comments or Questions Concerning Personnel Matters. Any Such Comments or Questions Will be Handled by the Appropriate Persons. Public Hearing Comments and Presentations Will be Limited to Five Minutes or Less per Person, nor Will Time Extensions be Permitted. No Duplication of Speakers will be Allowed.
- IV. Questions Posed by Speakers May, or May Not be Responded to by Council Members.
- V. Willful Disruption of, or the Breach of the Peace at, a Council Meeting may Result in the Removal of any Such Individuals or Groups from the Council Chambers.
(These Guidelines Are Also Posted at the Podium in the Council Chambers)

Please silence cell phones during the City Council meeting.

AGENDA

1. ROLL CALL
2. PLEDGE OF ALLEGIANCE
3. CONSIDERATION OF MINUTES OF THE JUNE 16, 2020 REGULAR COUNCIL MEETING, AS PUBLISHED IN THE CASPER STAR-TRIBUNE ON JUNE 26, 2020
4. CONSIDERATION OF MINUTES OF THE JUNE 16, 2020 EXECUTIVE SESSION – LITIGATION

We are **CASPER**

Communication Accountability Stewardship Professionalism Efficiency Responsiveness

5. CONSIDERATION OF BILLS AND CLAIMS

6. COMMUNICATIONS

A. From Persons Present

7. ESTABLISH DATE OF PUBLIC HEARING

A. Consent

1. Establish July 21, 2020, as the Public Hearing Date for Consideration of:

a. Ordinance Amending Sections of Chapter 6.04 - **Animal Care and Control**

8. PUBLIC HEARINGS

A. Ordinance

1. **Vacation of West 8th Street**, from South David to South Center Street.

B. Resolution

1. Adoption of Revisions to the Current Rate Resolution for **Residential and Commercial Solid Waste Collection, Recycling, and Disposal at the Casper Solid Waste Facility**.

9. RESOLUTIONS

A. Consent

1. Authorizing a Sole Source Contract for Professional Services with **Granite Peak Pump Station, Inc.**, in the Amount not to Exceed \$107,945, for **Watertronics Pump Station** for the Casper Municipal Golf Course.

2. Authorizing an Agreement with **Airgas** of Casper, Wyoming, in the Amount of \$52,495, for the Purchase and Installation of a **Machitech Silver Model Plasma Table to be Used in the Solid Waste Division**.

3. Authorizing a Contract for Professional Services with **Jacobs Engineering Group**, in the Amount of \$1,128,870 for the **North Platte Sanitary Sewer Rehabilitation Project**.

4. Authorizing amendment No. 1 to a Grant from the **Wyoming Water Development Commission** for Additional Funds in the Amount of \$643,000 for the **CY Booster Station Replacement Project**.

We are **CASPER**

Communication Accountability Stewardship Professionalism Efficiency Responsiveness

9. RESOLUTIONS (continued)

A. Consent

5. Authorizing a License Agreement with **Advanced Communications Technology, Inc.**, for Installation of **Buried Fiber Optic Cable** Infrastructure Within City Right-of-Way.
6. Authorizing Change Order No. 8 with **Haass Construction Company, Inc.**, in the Amount of \$35,375 and a Time Extension of 21 Days, for the **Casper Ice Arena Ice Chiller System Replacement Project**.
7. Authorizing a Right-of-Way Easement from the **Board of Natrona County Commissioners** as part of the **Midwest Avenue Reconstruction from Elm Street to Walnut Street Project**.
8. Authorizing Submission of an Application for a Fiscal Year 2021 Transportation Alternatives Program Funding from the **Wyoming Department of Transportation** in the Amount of \$500,000 for the **Paradise Valley to Robertson Road Bridge Project**.
9. Authorizing the Purchase of **Court Software and Services**, in the Amount of \$260,397, from **Tyler Technologies, Inc.**
10. Accepting a Grant from the **Wyoming Governor's Big Game Coalition**, in the Amount of \$10,000, to be Used to Fund **Wetlands Construction and Enhancement**.
11. Authorize an Amendment to the Professional Services Contract with **PowerPhone Total Response Emergency Medical Dispatch**, in the Total Amount of \$71,410.
12. Authorizing a Contract for Professional Services with the **Downtown Development Authority** for the Operation and Management of the **Downtown Parking Facilities** for the Period of July 1, 2020 through August 31, 2020.

10. MINUTE ACTION

A. Consent

1. Authorizing the Use of a **Patio for Restaurant Liquor License No. 44**, for Occasions by Cory, LLC, d/b/a **Occasions Entertainment Group**, Located at 303 South Wolcott Street.

We are **CASPER**

Communication Accountability Stewardship Professionalism Efficiency Responsiveness

11. INTRODUCTION OF MEASURES AND PROPOSALS BY MEMBERS OF THE CITY COUNCIL

12. ADJOURN INTO EXECUTIVE SESSION – LITIGATION AND PERSONNEL

13. ADJOURNMENT

Upcoming Council meetings

Council meetings

6:00 p.m. Tuesday, July 21, 2020– Council Chambers

6:00 p.m. Tuesday, August 4, 2020 – Council Chambers

Work sessions

4:30 p.m. Tuesday, July 14, 2020 –Council Chambers

4:30 p.m. Tuesday, July 28, 2020–Council Chambers

ZONING CLASSIFICATIONS

FC	Major Flood Channels & Riverbanks	PUD	Planned Unit Development
AG	Urban Agriculture	HM	Hospital Medical
R-1	Residential Estate	C-1	Neighborhood Convenience
R-2	One Unit Residential	C-2	General Business
R-3	One to Four Unit Residential	C-3	Central Business
R-4	High-Density Residential	C-4	Highway Business
R-5	Mixed Residential	M-1	Limited Industrial
R-6	Manufactured Home (Mobile) Park	M-2	General Industrial
PH	Park Historic	SMO	Soil Management Overlay
HO	Historic Overlay	ED	Education
OB	Office Business	OYD	Old Yellowstone District

We are **CASPER**

Communication Accountability Stewardship Professionalism Efficiency Responsiveness

COUNCIL PROCEEDINGS
 Casper City Hall – Video Conference Call
 June 16, 2020

1. ROLL CALL

Casper City Council met in regular session at 6:12 p.m., Tuesday, June 16, 2020. Present at City Hall: Mayor Freel and Vice-Mayor Lutz. Councilmembers Bates, Cathey, Hopkins, Huber, Johnson, Pacheco and Powell attended via conference call.

2. PLEDGE OF ALLEGIANCE

Mayor Freel led the audience in the Pledge of Allegiance.

3. MINUTES

Moved by Councilmember Cathey, seconded by Councilmember Hopkins, to, by minute action, approve the minutes of the June 2, 2020, regular Council meeting, as published in the Casper-Star Tribune on June 10, 2020. Motion passed.

4. EXECUTIVE SESSION MINUTES

Moved by Councilmember Johnson, seconded by Vice-Mayor Lutz, to, by minute action, approve the minutes of the June 2, 2020, executive session. Motion passed.

5. BILLS & CLAIMS

Moved by Councilmember Bates, seconded by Vice-Mayor Lutz, to, by minute action, approve payment of the June 16, 2020, bills and claims, as audited by City Manager Napier. Motion passed.

Bills & Claims 06/16/20

307CllsnCtr	Services	914.20
3D'sWldng	Services	2,000.00
477KM	Goods	278.00
71Const	Services	5,556.94
AMBI	Services	995.11
AceHdw	Goods	161.42
ACoyle	Reimb	1,088.42
Adecco	Services	1,513.20
Airgas	Goods	744.26
AllianceElect	Services	1,052.80
Alluretech	Goods	42.00
AlSCO	Services	407.96
Alumitech	Goods	4,987.75
AmeriTech	Goods	40,050.59
ARaver	Reimb	165.00
ARSFlood	Services	525.00
AtlasOffice	Goods	565.01
AtlasReprod	Services	203.74
B32Eng	Services	4,330.00
Bargreen	Goods	44.44

BnkofAmerica	Goods	102,740.23
BloedornLmbr	Goods	2,367.22
Breezytrees	Goods	950.00
Brenntag	Goods	9,995.70
BWilladson	Reimb	17.87
CATC	Funding	130,457.18
CsprPblcUt	Services	824,446.22
CsprStarTrib	Ads	4,878.88
CsprTire	Goods	45.00
CsprWinnlson	Goods	42.45
CtrlWySrSvcs	Funding	590,322.75
CtrlWYHspc	Funding	3,194.44
CenturyLink	Services	17,891.93
ChldrnsAdvc	Funding	5,808.88
CtyofCspr	Services	101,039.72
CMITeco	Goods	4,681.66
Comtrnx	Services	150.00
Convrgeone	Goods	31,360.09
CourtAppSpeci	Services	1,296.25
CPU	Goods	5,744.38
CrumElect	Services	11.14
DavidsonFxdIncm	Services	3,886.88
DavidsonMech	Services	5,359.00
DCourtade	Reimb	150.00
DennisSply	Goods	520.59
DesertMtn	Goods	4,097.25
DmndVogel	Goods	2,358.90
DooleyEnt	Goods	2,384.00
DPCInd	Goods	12,860.20
EmrgncyMed	Goods	899.40
EngDsgn	Services	1,737.50
FalconEnv	Goods	4,065.00
FrmrBros	Goods	77.26
FrfghtrsOfNC	Services	166.66
FirstData	Goods	22.85
FowelsCstm	Services	4,815.00
FrntlneFirePrt	Goods	1,505.00
FugroUSA	Services	42,147.33
Galls	Services	66.65
GlblSpctrum	Services	82,909.91
GolderAssoc	Services	25,503.00
Grainger	Goods	92.61
GranitePkPmp	Services	1,266.78
GravesCnslt	Services	9,000.00
HighPlnsConst	Services	513,034.40

HitekComm	Services	5,168.00
Homax	Goods	41,518.17
InnovativeData	Services	28,170.00
KnifeRiver	Goods	10,713.52
LairdPlstes	Goods	4,516.00
LwOffcHYoung	Services	1,350.00
LisasSpcnSpn	Services	395.00
LongBldg	Services	1,918.32
McMurry	Goods	216.50
MDay	Reimb	150.00
MillsPD	Services	257.93
MKolker	Reimb	71.84
MonsonJntrl	Services	10,229.62
Motion&Flow	Goods	266.52
Motorola	Goods	141,752.07
MtnStatesLitho	Services	616.20
MtnWestTele	Utilities	503.74
MunicipleCode	Services	450.00
Napa	Goods	169,565.27
NCHCorp	Goods	375.00
NCConserv	Services	35,000.00
NCSheriff	Services	257.93
NCPble	Funding	75,203.75
Nelson/Nygaard	Services	6,865.65
Norco	Goods	1,896.11
NWCntrcts	Services	1,424.98
OneCall	Services	1,155.75
PCNStrtgs	Goods	665.28
PlcnCorp	Goods	1,293.57
PltteRvrCrss	Goods	435.00
Pella	Goods	690.39
PrfrcLawEnf	Goods	16,147.00
RCavalluzzi	Reimb	99.70
RckyMtnPwr	Goods	101,808.58
Ricoh	Services	281.57
RJsCrpt	Services	80.00
RooterSwr	Goods	2,041.48
RussellInd	Goods	4,261.99
SheetMtlSpec	Goods	74,336.75
ShrwnWlms	Goods	547.02
Smarsh	Services	1,852.50
StofWY-DeptofAg	Services	50.00
StofWy	Services	6,748.47
Stateline7	Services	5,700.00
Sterling	Services	829.20

TopOffice	Services	128.20
TretoConst	Services	212,046.00
Trihydro	Goods	3,021.64
Tweeds	Services	571.42
Uniforms2Gear	Services	402.31
VeoliaEsTech	Services	6,328.35
Verizon	Goods	1,002.33
VermeerSl	Services	1,601.13
VolanceLng	Goods	143.94
WamcoLbs	Services	1,800.00
WrdwllWtr	Utilities	29.68
WColemanConst	Services	10,729.35
Wydor	Services	71.66
WyattElect	Services	5,250.00
WyOfficeProd	Goods	22,250.69
WySftyGrp	Goods	780.00
XeroxCorp	Services	221.08
Total		3,646,248.15

6. COMMUNICATIONS FROM PERSONS VIA TELEPHONE

Mayor Freel announced that several businesses had agreed to sponsor the Fourth of July fireworks display, but that at this time there would be no public festivities at the Casper Events Center.

Drew Perkins, representing Treto Construction, asked Council to re-consider the bid submitted by Treto Construction for the Midwest Avenue reconstruction contract. Councilmembers had questions for Mr. Perkins, which he addressed.

7. ESTABLISH PUBLIC HEARINGS

Moved by Councilmember Cathey, seconded by Councilmember Powell, to, by minute action: establish July 7, 2020, as the public hearing date for the consideration of the vacation of West 8th Street, from South David to South Center Street; and the adoption of revisions to the current rate resolution for residential and commercial solid waste collection, recycling, and disposal at the Casper Solid Waste Facility. Motion passed.

8.A.1 PUBLIC HEARING - RESOLUTION

Mayor Freel opened the public hearing for the consideration of budget amendment no. 3 to the fiscal year 2020 budget.

City Attorney Henley entered two (2) exhibits: correspondence from Tom Pitlick to J. Carter Napier, dated June 11, 2020 and an affidavit of publication, as published in the Casper-Star Tribune, dated June 4, 2020. City Manager Napier provided a brief report.

There being no one to speak for or against the issue, the public hearing was closed.

Following resolution read:

RESOLUTION NO. 20-135
A RESOLUTION AMENDING THE CURRENT BUDGET FOR
THE FISCAL YEAR ENDING JUNE 30, 2020.

Councilmember Powell presented the foregoing resolution for adoption. Seconded by Councilmember Hopkins. Motion passed.

8.A.2 PUBLIC HEARING - RESOLUTION

Mayor Freel opened the public hearing for the consideration of the fiscal year 2020-2021 budget.

City Attorney Henley entered two (2) exhibits: correspondence from Tom Pitlick to J. Carter Napier, dated June 10, 2020 and an affidavit of publication, as published in the Casper-Star Tribune, dated June 4, 2020. City Manager Napier provided a brief report.

There being no one to speak for or against the issue, the public hearing was closed.
Following resolution read:

RESOLUTION NO. 20-136
A RESOLUTION MAKING APPROPRIATIONS OF FUNDS TO
COVER EXPENDITURES OF THE CITY OF CASPER,
WYOMING FOR THE FISCAL YEAR OF JULY 1, 2020 TO
JUNE 30, 2021.

Councilmember Hopkins presented the foregoing resolution for adoption. Seconded by Councilmember Bates. Motion passed.

9.A ORDINANCE— THIRD READING

Following ordinance read:

ORDINANCE NO.12-20
AN ORDINANCE AMENDING SECTION 15.02.120 AND
15.04.070 OF THE CITY OF CASPER MUNICIPAL CODE.

Councilmember Powell presented the foregoing ordinance for approval, on third reading. Seconded by Vice-Mayor Lutz.

Individuals addressing the Council in opposition were: Linda Bergeron, 2355 Larkspur; Doug Bergeron, 2355 Larkspur; Brenda Mongold, 1216 S. Kenwood; Cathy Ide, 159 N. Wolcott; Eric Paulson, 751 N. Durbin; Pam Elrod, 12920 Dusty Lane; Wendy Degroot, 376 Zinnia; Jody Von Seggern, 1724 S. Wilson; Gia Dugan, 664 CY; and Justin Hackett, 4441 Moose.

Individuals addressing the Council in favor were: Christopher Gardner; Kim Summerall-Wright, Casper Housing Authority; Ruth Heald, Casper-Natrona County Health Department; and David Ziemer and Amy Taheri, Legal Aid of Wyoming, Inc.

Also speaking in opposition were: Josh Wheeler, 1950 Bonnie Brae; and Dale Zimmerle, 3035 Bellaire.

Councilmembers made statements about the subject and clarified several points they felt speakers had misunderstood or where unaware of. Mayor Freel requested staff address questions presented by the speakers.

Dan Elston, City Building Supervisor, addressed questions about pellet stoves and the warrant process.

Moved by Vice-Mayor Lutz, to amend the ordinance so it would pertain only to rentals and properties that have an executed land lord/renter agreement. She requested assistance with the language from the City Attorney. City Attorney Henley made a suggestion. Councilmember Huber suggested the phrase owner-occupied (as an exclusion). City Attorney Henley clarified the language and Vice-Mayor Lutz approved. Seconded by Councilmember Cathey. Council discussed the amendment at length. Councilmembers Hopkins, Huber, Pacheco and Powell voted nay. Motion to amend passed.

Moved by Councilmember Bates, to amend the ordinance by requiring the permission of the occupant of a property for people to take photos or videos of a property in order to obtain a warrant for entry. Motion died for a lack of a second.

Council then voted on the ordinance, on third reading, as amended. Motion passed. Ordinance as amended follows:

ORDINANCE NO. 12-20
AN ORDINANCE AMENDING SECTION 15.02.120 AND
15.04.070 OF THE CITY OF CASPER MUNICIPAL CODE.

WHEREAS, it is the desire of the governing body of the City of Casper to provide, within the City's existing Ordinance structure, a means to protect against and/or remediate STRUCTURES UNSAFE FOR HUMAN OCCUPANCY; and,

WHEREAS, the current Casper Code in Sections 15.02.010 et. seq. addresses one and two family dwellings; and,

WHEREAS, the current Casper Code in Sections 15.04.010 et. seq. addresses structures other than one and two family dwellings;

NOW, THEREFORE, BE IT ORDAINED BY THE GOVERNING BODY OF THE CITY OF CASPER, WYOMING:

SECTION 1:

Section 15.02.120 of the Casper Municipal Code is created to define and control unsafe structures, but section 15.02.120 shall not apply to owner occupied residential properties.

[1] **Unsafe Structures.** An unsafe structure is one that is found to be dangerous to the life, health, property or safety of the public or the occupants of the structure by not providing minimum safeguards to protect or warn occupants in the event of fire, or because the structure contains unsafe

equipment or is so damaged, decayed, dilapidated, structurally unsafe or of such faulty construction or unstable foundation, that partial or complete collapse is possible.

[2] **Conditions.** Structures or existing equipment that are or hereafter become unsafe, unsanitary or deficient because of inadequate means of egress, inadequate light, ventilation, or which constitute a fire hazard, or are otherwise dangerous to human life or the public welfare, or that involve illegal or improper occupancy or hazardous maintenance as defined herein, shall be deemed unsafe. Unsafe structures shall be taken down and removed or made safe, as the building official deems necessary and as provided for in this section.

- A. Inadequate means of egress. Means a safe, continuous and unobstructed path of travel shall be provided from any point in a building or structure to the public way. Means of egress shall comply with the International Fire Code. Locked doors shall be able to be readily opened from the side from which egress is to be made without the use of keys, special knowledge or effort, except where permitted by the International Building Code. Emergency escape openings shall be maintained in accordance with the code in effect at the time of construction.
- B. Multi-Family Egress Lighting. Every common hall and stairway in residential multi-family occupancies shall be lighted at all times. Interior and exterior means of egress, stairways shall be illuminated at all times with not less than 1-foot candle at floors, landings and treads.
- C. Ventilation. Every habitable space shall be ventilated by natural or mechanical means. Natural ventilation means each habitable space shall have not less than one operable window. Mechanical ventilation requires supply and return or exhaust air be provided by approved equipment and produce equal amounts of supply and return or exhaust air. Bathrooms, toilet rooms, closets, halls, storage or utility spaces, and similar areas are not considered habitable spaces.
- D. Fire Hazard - multi-family dwellings and rental units. The required fire resistant-rated construction, including walls, fire stops, shaft enclosures, partitions, smoke barriers, floors, ceilings and sprayed fire resistant materials shall be maintained to limit the spread of fire and smoke. Existing Fire protection systems shall be inspected and maintained. Smoke alarms shall be installed and maintained in institutional and residential dwellings where required. Carbon Monoxide alarms shall be installed and maintained when applicable.
- E. Heating Facilities. Dwellings shall be provided with an approved heating appliance such as a furnace or boiler capable of maintaining a room temperature of 68 degrees Fahrenheit in all habitable rooms, bathrooms, and toilet rooms. Cooking appliances shall not be used, nor shall portable unvented fuel burning space heaters be used, as a means to provide required heating. Electrical space heaters are allowed for supplemental heat only.

Exception: Fuel burning space heaters shall be allowed for emergency use only, until repairs are complete on the required approved heating appliance.

- F. **Electrical System Hazards.** Where it is found that the electrical system in a structure constitutes a hazard to the occupants or the structure by reason of inadequate service, improper fusing, insufficient receptacles and lighting outlets, improper wiring or installation, deterioration or damage, or for similar reasons, the code official shall require the defects to be corrected to eliminate the hazard.
- G. **Water system.** Every sink, lavatory, bathtub or shower, drinking fountain, water closet or other plumbing fixture shall be properly connected to either a public water system or to an approved private water system. Kitchen sinks, lavatories, laundry facilities, bathtubs and showers shall be supplied with hot or tempered and cold running water in accordance with the International Plumbing Code.
- H. **Sanitary Drainage.** Plumbing fixtures shall be properly connected to either a public sewer system or to an approved private sewage septic system. Every plumbing stack, vent, waste and sewer line shall function properly and be kept free from obstructions, leaks and defects. Prohibited: Sanitary waste shall not be collected, stored or disposed of on any property other than as referenced herein.
- I. A vacant structure that is not secured against entry shall be deemed unsafe.

[3] **Structures unfit for human occupancy.** A structure is unfit for human occupancy whenever the code official finds that such structure is unsafe, unlawful or, because of the degree to which the structure is in disrepair or lacks maintenance, is unsanitary, vermin or rat infested, contains filth and contamination, or lacks ventilation, illumination, sanitary or heating facilities or other essential equipment required by ordinance or code, or because the location of the structure or the facility or equipment within the structure constitutes a hazard to the occupants of the structure or to the public.

[4] **Unlawful Structure.** An unlawful structure is one found whole or in part to be occupied by more persons than permitted by code, or was erected, altered or occupied contrary to law.

SECTION 2:

Section 15.04.070-Section 105.1, which shall not apply to owner occupied residential structures, is amended to read:

Section 105.1 – Structures Unsafe for Human Occupancy

[1] **Unsafe Structures.** An unsafe structure is one that is found to be dangerous to the life, health, property or safety of the public or the occupants of the structure by not providing minimum safeguards to protect or warn occupants in the event of fire, or because the structure contains unsafe equipment or is so damaged, decayed, dilapidated, structurally unsafe or of such faulty construction or unstable foundation, that partial or complete collapse is possible.

[2] **Conditions.** Structures or existing equipment that are or hereafter become unsafe, unsanitary or deficient because of inadequate means of egress, inadequate light, ventilation, or which

constitute a fire hazard, or are otherwise dangerous to human life or the public welfare, or that involve illegal or improper occupancy or hazardous maintenance as defined herein, shall be deemed unsafe. Unsafe structures shall be taken down and removed or made safe, as the building official deems necessary and as provided for in this section.

- A. Inadequate means of egress. Means a safe, continuous and unobstructed path of travel shall be provided from any point in a building or structure to the public way. Means of egress shall comply with the International Fire Code. Locked doors shall be able to be readily opened from the side from which egress is to be made without the use of keys, special knowledge or effort, except where permitted by the International Building Code. Emergency escape openings shall be maintained in accordance with the code in effect at the time of construction.
- B. Multi-Family Egress Lighting. Every common hall and stairway in residential multi-family occupancies shall be lighted at all times. Interior and exterior means of egress, stairways shall be illuminated at all times with not less than 1-foot candle at floors, landings and treads.
- C. Ventilation. Every habitable space shall be ventilated by natural or mechanical means. Natural ventilation means each habitable space shall have not less than one operable window. Mechanical ventilation requires supply and return or exhaust air be provided by approved equipment and produce equal amounts of supply and return or exhaust air. Bathrooms, toilet rooms, closets, halls, storage or utility spaces, and similar areas are not considered habitable spaces.
- D. Fire Hazard - multi-family dwellings and rental units. The required fire resistant-rated construction, including walls, fire stops, shaft enclosures, partitions, smoke barriers, floors, ceilings and sprayed fire resistant materials shall be maintained to limit the spread of fire and smoke. Existing Fire protection systems shall be inspected and maintained. Smoke alarms shall be installed and maintained in institutional and residential dwellings where required. Carbon Monoxide alarms shall be installed and maintained when applicable.
- E. Heating Facilities. Dwellings shall be provided with an approved heating appliance such as a furnace or boiler capable of maintaining a room temperature of 68 degrees Fahrenheit in all habitable rooms, bathrooms, and toilet rooms. Cooking appliances shall not be used, nor shall portable unvented fuel burning space heaters be used, as a means to provide required heating. Electrical space heaters are allowed for supplemental heat only.

Exception: Fuel burning space heaters shall be allowed for emergency use only, until repairs are complete on the required approved heating appliance.

- F. Electrical System Hazards. Where it is found that the electrical system in a structure constitutes a hazard to the occupants or the structure by reason of inadequate service, improper fusing, insufficient receptacles and lighting outlets, improper wiring or installation, deterioration or damage, or for similar reasons, the code official shall require the defects to be corrected to eliminate the hazard.

G. Water system. Every sink, lavatory, bathtub or shower, drinking fountain, water closet or other plumbing fixture shall be properly connected to either a public water system or to an approved private water system. Kitchen sinks, lavatories, laundry facilities, bathtubs and showers shall be supplied with hot or tempered and cold running water in accordance with the International Plumbing Code.

H. Sanitary Drainage. Plumbing fixtures shall be properly connected to either a public sewer system or to an approved private sewage septic system. Every plumbing stack, vent, waste and sewer line shall function properly and be kept free from obstructions, leaks and defects. Prohibited: Sanitary waste shall not be collected, stored or disposed of on any property other than as referenced herein.

I. A vacant structure that is not secured against entry shall be deemed unsafe.

[3] **Structures unfit for human occupancy.** A structure is unfit for human occupancy whenever the code official finds that such structure is unsafe, unlawful or, because of the degree to which the structure is in disrepair or lacks maintenance, is unsanitary, vermin or rat infested, contains filth and contamination, or lacks ventilation, illumination, sanitary or heating facilities or other essential equipment required by ordinance or code, or because the location of the structure or the facility or equipment within the structure constitutes a hazard to the occupants of the structure or to the public.

[4] **Unlawful Structure.** An unlawful structure is one found whole or in part to be occupied by more persons than permitted by code, or was erected, altered or occupied contrary to law.

[5] **Unlawful Activity.** It shall be unlawful for any person, firm, or corporation to erect, construct, enlarge, alter, repair, move, improve, remove, convert, demolish, equip, use, occupy, or maintain any building or structure in the city, or cause or permit the same to be done, in violation of this code.

SECTION 3:

This ordinance shall be in full force and effect from and after passage on three readings and publication.

PASSED ON 1st reading the 19th day of May, 2020.

PASSED ON 2nd reading the 2nd day of June, 2020

PASSED, APPROVED, AND ADOPTED, on the 3rd and final reading the 16th day of June, 2020.

9.B ORDINANCE— THIRD READING

Following ordinance read:

ORDINANCE NO. 13-20

AN ORDINANCE APPROVING A ZONE CHANGE OF
LOTS 344 AND 345, KENWOOD ADDITION SUBDIVISION
IN THE CITY OF CASPER, WYOMING.

WHEREAS, an application has been made to rezone Lots 344 and 345, Kenwood Addition Subdivision in the City of Casper, located at the southwest corner of East 12th Street and South Melrose Street, from zoning classification R-2 (One Unit Residential) to C-2 (General Business); and,

WHEREAS, after a public hearing on April 16, 2020, the City of Casper Planning and Zoning Commission passed a motion recommending that City Council approve the zone change request; and,

WHEREAS, the governing body of the City of Casper finds that the above described zone change should be approved.

NOW, THEREFORE, BE IT ORDAINED BY THE GOVERNING BODY OF THE CITY OF CASPER, WYOMING:

SECTION 1:

Lots 344 and 345, Kenwood Addition, are hereby rezoned from R-2 (One Unit Residential) to C-2 (General Business).

SECTION 2:

This ordinance shall be in full force and effect from and after passage on three readings and publication pursuant to law.

PASSED ON 1st reading the 19th day of May, 2020.

PASSED ON 2nd reading the 2nd day of June, 2020

PASSED, APPROVED, AND ADOPTED, on the 3rd and final reading the 16th day of June, 2020.

Councilmember Hopkins presented the foregoing ordinance for approval, on third reading. Seconded by Vice-Mayor Lutz. There being no one to speak regarding the ordinance, and no discussion or amendments, motion passed.

9.C ORDINANCE— THIRD READING

Following ordinance read:

ORDINANCE NO. 14-20

AN ORDINANCE APPROVING THE GORGAN HILLS ADDITION SUBDIVISION AGREEMENT AND A VACATION AND REPLAT CREATING GORGAN HILLS ADDITION, COMPRISING 31.52 ACRES, MORE OR LESS.

WHEREAS, an application has been made TO VACATE AND REPLAT Lot 1, Block 1, Cemetery Addition, to create the Gorgan Hills Addition Subdivision, comprising 31.52- acres, more or less, generally located south of West 46th Street and east of Moose Street (the "plat"); and,

WHEREAS, a written subdivision agreement will be entered into with the City of Casper, which will be approved with the plat upon third reading of this ordinance; and,

WHEREAS, the vacation and replat requires approval by ordinance following a public hearing; and,

WHEREAS, after a public hearing, the City of Casper Planning and Zoning Commission passed a motion recommending that the City Council approve the requested vacation and replat; and,

WHEREAS, the governing body of the City of Casper finds that the above described vacation, replat and subdivision agreement should be approved.

NOW, THEREFORE, BE IT ORDAINED BY THE GOVERNING BODY OF THE CITY OF CASPER, WYOMING:

SECTION 1:

That the Mayor is hereby authorized and directed to execute, and the City Clerk to attest, the Gorgan Hills Subdivision Agreement.

SECTION 2:

That the vacation and replat creating the Gorgan Hills Addition is hereby approved under terms and conditions of the Gorgan Hills Subdivision Agreement.

PASSED ON 1st reading the 19th day of May, 2020.

PASSED ON 2nd reading the 2nd day of June, 2020

PASSED, APPROVED, AND ADOPTED, on the 3rd and final reading the 16th day of June, 2020.

Councilmember Hopkins presented the foregoing ordinance for approval, on third reading. Seconded by Councilmember Huber.

Speaking in support was Jesse Morgan, applicant.

Individuals speaking in opposition were: Cheryl Hackett, 4441 Moose; Bill Birkett, 4610 Puma; Connie Rodgers, 4511 Moose; Eric Lawrence, 3710 W. 46th; Susan Frank, 3519 Aspen; Wendy Degroot, 376 Zinnia; and Linda Stribling, 3610 W. 46th. City Manager Napier addressed several questions about the level of responsibility and costs to City for the infrastructure of the development.

Councilmember Bates requested clarification on questions from some of the speakers. City Manager Napier requested that staff address the topic of fire hydrants and fire protection of the area. Mayor Freel requested information about whether the cross street is needed for a response. Fire Chief Solberg requested the support of the code for cross streets, hydrants and a cul-de-sac.

Mayor Freel asked about the cross street at the north end of the property. Craig Collins, City Planner, indicated that the street would have limited value because it is already very close to existing streets.

Councilmember Powell asked for more information about fire suppression issues with the development, including if a cross street is needed for this purpose. Fire Chief Solberg indicated that a cross street would help support fire suppression because it would provide a means to access the wildland interface.

Councilmember Cathey asked about service for residential fires in the area and expressed his concern about future connectivity as the area continues to be developed. Fire Chief Solberg indicated that access for fire suppression is important, but so is access for emergency medical support. Councilmember Hopkins shared his opinion on water service for fire suppression in the area. Councilmember Huber asked how a lack of a cross street can be dealt with. Fire Chief Solberg said that things would depend on the location of driveways, but shared that if things aren't built out now, then it is very unlikely that they will be added later.

Councilmember Huber shared his thoughts on the matter. Councilmember Cathey asked city staff if the cross street could be placed up the hill as proposed. Andrew Beamer, Public Services Director, said that it could but that switchbacks would probably be needed to lessen the grade. Councilmembers Cathey and Bates spoke about other places in the community where steep roads have been constructed and said that a cross street should be built. Councilmember Hopkins indicated that the cross street is not needed because fires can be managed from the higher elevation. Vice-Mayor Lutz asked if the unpaved easement could be used to access these homes and what driveway requirements are in place for this development. Mr. Collins said that the primary access to homes would need to be paved, but not necessarily other access, such as an alley and that the standards for this development are what we think of as typical in the City. Vice-Mayor Lutz asked if the developers had planned for this and Mr. Collins said he would need to confirm with the applicant. Councilmember Cathey expressed concerns about the compliance of the developer to the City standards.

Moved by Councilmember Bates, to add the cross street that was recommended by the Planning and Zoning Commission. Seconded by Councilmember Cathey. Council discussed the matter. Councilmembers Bates, Cathey and Powell voted aye. Mayor Freel abstained. Motion to amend failed. Council then voted on the ordinance, on third reading, as read. Councilmembers Bates and Cathey voted nay. Mayor Freel abstained. Motion passed.

10. CONSENT RESOLUTIONS

The following resolutions were considered, by consent agenda:

RESOLUTION NO. 20-123

A RESOLUTION AUTHORIZING A CONTRACT WITH POWERPHONE, INC. TO INSTALL A TOTAL RESPONSE COMPUTER AIDED CALL HANDLING SYSTEM TO GAIN A COMPATIBLE APPROACH TO EMERGENCY MEDICAL DISPATCH.

RESOLUTION NO. 20-124

A RESOLUTION AUTHORIZING ACCEPTANCE OF A GRANT FROM THE NATRONA COUNTY RECREATION JOINT POWERS BOARD

RESOLUTION NO. 20-125

A RESOLUTION A CONTRACT BETWEEN THE CASPER AREA METROPOLITAN PLANNING ORGANIZATION AND AECOM TECHNICAL SERVICES, INC. FOR THE THIRD PARTY QUALITY CONTROL/QUALITY ASSURANCE OF GEOGRAPHIC INFORMATION SYSTEM OF GEOGRAPHIC INFORMATION SYSTEM DELIVERABLES FROM THE 2020 AERIAL MAPPING UPDATE IN AN AMOUNT OF \$15,850.

RESOLUTION NO. 20-126

A RESOLUTION AUTHORIZING AMENDMENT NO. 1 TO THE CONTRACT FOR PROFESSIONAL SERVICES WITH CIVIL ENGINEERING PROFESSIONALS, INC., FOR THE 2020 WATER SYSTEM MASTER PLAN.

RESOLUTION NO. 20-127

A RESOLUTION AUTHORIZING AN AGREEMENT WITH 71 CONSTRUCTION, INC., FOR THE MIDWEST AVENUE RECONSTRUCTION – ELM STREET TO WALNUT STREET PROJECT NO. 18-066.

RESOLUTION NO. 20-128

A RESOLUTION AUTHORIZING AN AGREEMENT WITH ATLANTIC ELECTRIC, INC., FOR THE LUMINAIRE SERVICES FY21-FY24, PROJECT NO. 20-009.

RESOLUTION NO. 20-129

A RESOLUTION AUTHORIZING AMENDMENT NO. 1 TO THE PROJECT AGREEMENT WITH WYOMING WATER DEVELOPMENT COMMISSION FOR FUNDING OF THE WEST CASPER ZONE II WATER SYSTEM IMPROVEMENTS, PROJECT NO. 15-59.

RESOLUTION NO. 20-130

A RESOLUTION AUTHORIZING AN AGREEMENT WITH TRETO CONSTRUCTION, LLC, FOR THE RIDGECREST ZONE 2 AND ZONE 3 WATERLINE REPLACEMENT, PROJECT NO. 19-037.

RESOLUTION NO. 20-131

A RESOLUTION ACCEPTING A GRANT FROM THE WYOMING OFFICE OF HOMELAND SECURITY.

RESOLUTION NO. 20-132

A RESOLUTION AUTHORIZING THE LEVYING OF 8 MILLS OF PROPERTY TAX BY THE NATRONA COUNTY ASSESSOR ON BEHALF OF THE CITY OF CASPER.

RESOLUTION NO. 20-133

A RESOLUTION AUTHORIZING A CONTRACT WITH COMMUNICATION TECHNOLOGIES, INC. TO PROVIDE AN EVENTIDE LOGGING RECORDER TO PROVIDE A RADIO AND PHONE CALL RECORDING AT THE PUBLIC SAFETY COMMUNICATION CENTER.

RESOLUTION NO. 20-134

A RESOLUTION AUTHORIZING AN AGREEMENT BETWEEN THE CITY OF CASPER AND THE UNIVERSITY OF WYOMING FOR THE PURPOSE OF A JOINT HORTICULTURE SERVICE.

Councilmember Hopkins presented the foregoing twelve (12) resolutions for adoption. Seconded by Vice-Mayor Lutz. Motion passed.

11. INTRODUCTION OF MEASURES AND PROPOSALS

Councilmember Bates asked that Council support two potential upcoming events in the downtown. Councilmember Powell asked that Council consider a non-discrimination ordinance for the lesbian, gay, bisexual, transgender, and queer (LGBTQ) community, which would protect their housing and employment rights.

Mayor Freel stated that the recycling program was being re-opened and that three pools would soon be opened. He also thanked the sponsors of the Fourth of July fireworks for their donations and staff for their work on the project.

12. ADJOURN INTO EXECUTIVE SESSION

Mayor Freel noted the next meetings of the City Council will be a work session to be held at 4:30 p.m., Tuesday, June 23, 2020; and, a regular Council meeting to be held at 6:00 p.m., Tuesday, July 7, 2020, with the locations to be determined.

At 10:10 p.m., it was moved Councilmember Hopkins, seconded by Vice-Mayor Lutz, to adjourn into executive session to discuss litigation. Motion passed.

At 10:32 p.m., it was moved by Councilmember Cathey, seconded by Vice-Mayor Lutz, to adjourn the executive session. Motion passed.

13. ADJOURNMENT

At 10:33 p.m., it was moved by Councilmember Cathey, seconded by Councilmember Huber, to adjourn the regular Council meeting. Motion passed.

ATTEST:

CITY OF CASPER, WYOMING
A Municipal Corporation

Fleur Tremel
City Clerk

Steven K. Freel
Mayor

City of Casper - Bills and Claims for July 7, 2020

- Total For

- ALL DEPARTMENTS

307 COLLISION

307 COLLISION	Fleet Maintenance Fund	191937 repairs- AMOUNT LESS SALES TAX	\$4,342.42
---------------	------------------------	---------------------------------------	------------

<i>307 COLLISION - Total For Fleet Maintenance Fund</i>			<i>\$4,342.42</i>
---	--	--	-------------------

307 COLLISION - ALL DEPARTMENTS			\$4,342.42
--	--	--	-------------------

477 KM LLC

477 KM LLC	Refuse - Recycling	COVID 19 disinfect depot	\$4,999.62
------------	--------------------	--------------------------	------------

477 KM LLC	Refuse - Recycling	COVID 19 disinfect depot	\$110.38
------------	--------------------	--------------------------	----------

<i>477 KM LLC - Total For Refuse - Recycling</i>			<i>\$5,110.00</i>
--	--	--	-------------------

477 KM LLC - ALL DEPARTMENTS			\$5,110.00
-------------------------------------	--	--	-------------------

4AllPromos

4AllPromos	Fire-EMS Operations	Toddy Ice Cooling Active Band with CFD Logo	\$689.89
------------	---------------------	---	----------

<i>4AllPromos - Total For Fire-EMS Operations</i>			<i>\$689.89</i>
---	--	--	-----------------

4AllPromos - ALL DEPARTMENTS			\$689.89
-------------------------------------	--	--	-----------------

4IMPRINT

4IMPRINT	Police State Grants	victim witness volunteer jackets/coaster	\$1,659.45
----------	---------------------	--	------------

<i>4IMPRINT - Total For Police State Grants</i>			<i>\$1,659.45</i>
4IMPRINT - ALL DEPARTMENTS			\$1,659.45

5.11, INC.

5.11, INC.	Fire-EMS Operations	Uniform	\$146.98
<i>5.11, INC. - Total For Fire-EMS Operations</i>			<i>\$146.98</i>
5.11, INC. - ALL DEPARTMENTS			\$146.98

71 CONSTRUCTION, INC

71 CONSTRUCTION, INC	Water Distribution	1/2" Hot Mix for Conwell water line project	\$36,062.16
<i>71 CONSTRUCTION, INC - Total For Water Distribution</i>			<i>\$36,062.16</i>
71 CONSTRUCTION, INC - ALL DEPARTMENTS			\$36,062.16

A.M.B.I. & SHIPPING,

A.M.B.I. & SHIPPING,	City Attorney	Postage	\$40.76
<i>A.M.B.I. & SHIPPING, - Total For City Attorney</i>			<i>\$40.76</i>
A.M.B.I. & SHIPPING,	Code Enforcement	stamps	\$517.80
<i>A.M.B.I. & SHIPPING, - Total For Code Enforcement</i>			<i>\$517.80</i>
A.M.B.I. & SHIPPING,	Customer Service	Postage	\$610.36
<i>A.M.B.I. & SHIPPING, - Total For Customer Service</i>			<i>\$610.36</i>
A.M.B.I. & SHIPPING,	Engineering	Postage	\$25.00
<i>A.M.B.I. & SHIPPING, - Total For Engineering</i>			<i>\$25.00</i>
A.M.B.I. & SHIPPING,	Ft. Caspar Museum	Postage	\$1.80
A.M.B.I. & SHIPPING,	Ft. Caspar Museum	Postage	\$5.25
A.M.B.I. & SHIPPING,	Ft. Caspar Museum	Postage	\$1.20
<i>A.M.B.I. & SHIPPING, - Total For Ft. Caspar Museum</i>			<i>\$8.25</i>
A.M.B.I. & SHIPPING,	Human Resources	Postage	\$103.40
<i>A.M.B.I. & SHIPPING, - Total For Human Resources</i>			<i>\$103.40</i>
A.M.B.I. & SHIPPING,	Municipal Court	Postage	\$439.92
<i>A.M.B.I. & SHIPPING, - Total For Municipal Court</i>			<i>\$439.92</i>
A.M.B.I. & SHIPPING,	Parks - Parks Maint.	Postage	\$16.16
<i>A.M.B.I. & SHIPPING, - Total For Parks - Parks Maint.</i>			<i>\$16.16</i>
A.M.B.I. & SHIPPING,	Planning	stamps	\$285.00

A.M.B.I. & SHIPPING, - Total For Planning \$285.00

A.M.B.I. & SHIPPING, - ALL DEPARTMENTS \$2,046.65

AAA LANDSCAPING

AAA LANDSCAPING Balefill - Disposal & Landfill Mowing and trimming grass \$165.00

AAA LANDSCAPING - Total For Balefill - Disposal & Landfill \$165.00

AAA LANDSCAPING Code Enforcement Mowing on honeysuckle \$188.68

AAA LANDSCAPING Code Enforcement 2118 jefferson mowing \$89.68

AAA LANDSCAPING - Total For Code Enforcement \$278.36

AAA LANDSCAPING - ALL DEPARTMENTS \$443.36

ACCENT ENVIROBALE, I

ACCENT ENVIROBALE, I Balefill - Baler Processing Joy stick button \$702.58

ACCENT ENVIROBALE, I - Total For Balefill - Baler Processing \$702.58

ACCENT ENVIROBALE, I - ALL DEPARTMENTS \$702.58

ACTION GLASS

ACTION GLASS Buildings & Structures Fund Glass repair supplies for North Casper Clubhous \$13.73

ACTION GLASS - Total For Buildings & Structures Fund \$13.73

ACTION GLASS - ALL DEPARTMENTS \$13.73

ACTION GLASS INC

ACTION GLASS INC Buildings & Structures Fund Glass repair for Golf Maintenance Shop \$261.62

ACTION GLASS INC Buildings & Structures Fund Failed attempt to credit for sales tax \$0.65

ACTION GLASS INC Buildings & Structures Fund parking garage repairs \$765.91

ACTION GLASS INC - Total For Buildings & Structures Fund \$1,028.18

ACTION GLASS INC - ALL DEPARTMENTS \$1,028.18

ADECCO USA, INC.

ADECCO USA, INC. Balefill - Disposal & Landfill Contract labor \$465.60

ADECCO USA, INC. Balefill - Disposal & Landfill contract labor \$582.00

ADECCO USA, INC. - Total For Balefill - Disposal & Landfill \$1,047.60

ADECCO USA, INC. - ALL DEPARTMENTS **\$1,047.60**

ADOBE CREATIVE CLOUD

ADOBE CREATIVE CLOUD	Refuse - Recycling	COMPUTER SOFTWARE STORES - ADOBE	\$52.99
ADOBE CREATIVE CLOUD	Refuse - Recycling	COMPUTER SOFTWARE STORES	\$52.99
ADOBE CREATIVE CLOUD	Refuse - Recycling	COMPUTER SOFTWARE STORES	\$52.99

ADOBE CREATIVE CLOUD - Total For Refuse - Recycling *\$158.97*

ADOBE CREATIVE CLOUD - ALL DEPARTMENTS **\$158.97**

AGTERRA TECHNOLOGIES

AGTERRA TECHNOLOGIES	Weed & Pest Fund	Sprayer Log annual fee	\$1,300.00
----------------------	------------------	------------------------	------------

AGTERRA TECHNOLOGIES - Total For Weed & Pest Fund *\$1,300.00*

AGTERRA TECHNOLOGIES - ALL DEPARTMENTS **\$1,300.00**

AHERN RENTALS INC

AHERN RENTALS INC	Water Distribution	GLASS BEADS	\$67.18
-------------------	--------------------	-------------	---------

AHERN RENTALS INC - Total For Water Distribution *\$67.18*

AHERN RENTALS INC - ALL DEPARTMENTS **\$67.18**

AIR INNOVATIONS

AIR INNOVATIONS	Balefill - Baler Processing	Service hvac	\$85.00
-----------------	-----------------------------	--------------	---------

AIR INNOVATIONS - Total For Balefill - Baler Processing *\$85.00*

AIR INNOVATIONS - ALL DEPARTMENTS **\$85.00**

AIRGAS USA LLC

AIRGAS USA LLC	Balefill - Disposal & Landfill	Tools	\$71.72
----------------	--------------------------------	-------	---------

AIRGAS USA LLC	Balefill - Disposal & Landfill	Safety vests	\$160.00
----------------	--------------------------------	--------------	----------

AIRGAS USA LLC - Total For Balefill - Disposal & Landfill *\$231.72*

AIRGAS USA LLC - ALL DEPARTMENTS **\$231.72**

AIRGAS USA, LLC

AIRGAS USA, LLC	Buildings & Structures Fund	Gas for plumbing work for Parks	\$57.47
<i>AIRGAS USA, LLC - Total For Buildings & Structures Fund</i>			<i>\$57.47</i>
AIRGAS USA, LLC	Water Distribution	Safety supplies	\$244.60
<i>AIRGAS USA, LLC - Total For Water Distribution</i>			<i>\$244.60</i>
AIRGAS USA, LLC - ALL DEPARTMENTS			\$302.07

ALBERTSONS #0060

ALBERTSONS #0060	Engineering	BREAKROOM SUPPLIES	\$110.19
<i>ALBERTSONS #0060 - Total For Engineering</i>			<i>\$110.19</i>
ALBERTSONS #0060	Human Resources	Chili Skate Night Supplies	\$10.98
<i>ALBERTSONS #0060 - Total For Human Resources</i>			<i>\$10.98</i>
ALBERTSONS #0060 - ALL DEPARTMENTS			\$121.17

ALL OUT FIRE EXTINGU

ALL OUT FIRE EXTINGU	Refuse - Residential	FIRE EXTINGUISHER 222285	\$120.00
<i>ALL OUT FIRE EXTINGU - Total For Refuse - Residential</i>			<i>\$120.00</i>
ALL OUT FIRE EXTINGU - ALL DEPARTMENTS			\$120.00

ALLPARTITIONS

ALLPARTITIONS	Buildings & Structures Fund	Partition parts for Golf Course Clubhouse	\$48.00
<i>ALLPARTITIONS - Total For Buildings & Structures Fund</i>			<i>\$48.00</i>
ALLPARTITIONS - ALL DEPARTMENTS			\$48.00

ALSCO

ALSCO	Balefill - Baler Processing	Uniforms	\$82.16
ALSCO	Balefill - Baler Processing	Uniforms	\$82.16
ALSCO	Balefill - Baler Processing	Uniforms	\$82.16
<i>ALSCO - Total For Balefill - Baler Processing</i>			<i>\$246.48</i>
ALSCO	Balefill - Disposal & Landfill	mats	\$53.30
ALSCO	Balefill - Disposal & Landfill	Floor mats	\$53.50
ALSCO	Balefill - Disposal & Landfill	floor mats	\$53.50
<i>ALSCO - Total For Balefill - Disposal & Landfill</i>			<i>\$160.30</i>
ALSCO	Police Federal Grants	laundry	\$15.00

ALSCO	Police Federal Grants	laundry	\$15.00
ALSCO	Police Federal Grants	Towels, laundry	\$15.00
ALSCO	Police Federal Grants	laundry	\$15.00
<i>ALSCO - Total For Police Federal Grants</i>			<i>\$60.00</i>
ALSCO	Refuse - Residential	Uniforms	\$56.10
ALSCO	Refuse - Residential	Uniforms	\$56.10
ALSCO	Refuse - Residential	Uniforms	\$56.10
<i>ALSCO - Total For Refuse - Residential</i>			<i>\$168.30</i>
ALSCO - ALL DEPARTMENTS			\$635.08

ALSCO INC.

ALSCO INC.	WWTP Operations	LAUNDRY, CLEANING, AND GARMENT SERVICES	\$524.68
<i>ALSCO INC. - Total For WWTP Operations</i>			<i>\$524.68</i>
ALSCO INC. - ALL DEPARTMENTS			\$524.68

AMAZON.COM GK6KB23P3

AMAZON.COM GK6KB23P3	Customer Service	Marlene's Keyboard - mouse-less.	\$63.99
<i>AMAZON.COM GK6KB23P3 - Total For Customer Service</i>			<i>\$63.99</i>
AMAZON.COM GK6KB23P3 - ALL DEPARTMENTS			\$63.99

AMAZON.COM MS3X215E2

AMAZON.COM MS3X215E2	Aquatics - Pool	AED Batteries	\$335.72
<i>AMAZON.COM MS3X215E2 - Total For Aquatics - Pool</i>			<i>\$335.72</i>
AMAZON.COM MS3X215E2 - ALL DEPARTMENTS			\$335.72

AMAZON.COM MY1SM0VT2

AMAZON.COM MY1SM0VT	Rec Center - Operations	HIGHLIGHTERS, GLUE, LAMINATION	\$28.14
<i>AMAZON.COM MY1SM0VT2 - Total For Rec Center - Operations</i>			<i>\$28.14</i>
AMAZON.COM MY1SM0VT2 - ALL DEPARTMENTS			\$28.14

AMAZON.COM MY2GA12X0

AMAZON.COM MY2GA12X0	Municipal Court	Office Supplies	\$15.41
----------------------	-----------------	-----------------	---------

AMAZON.COM MY2GA12X0 - Total For Municipal Court	\$15.41
AMAZON.COM MY2GA12X0 - ALL DEPARTMENTS	\$15.41

AMERIGAS - CASPER

AMERIGAS - CASPER	Balefill - Disposal & Landfill	Forklift propane	\$193.86
<i>AMERIGAS - CASPER - Total For Balefill - Disposal & Landfill</i>			\$193.86
AMERIGAS - CASPER - ALL DEPARTMENTS			\$193.86

AMERI-TECH EQUIPMENT

AMERI-TECH EQUIPMENT	Balefill - Disposal & Landfill	Roll off liners paint bin	\$1,996.32
<i>AMERI-TECH EQUIPMENT - Total For Balefill - Disposal & Landfill</i>			\$1,996.32
AMERI-TECH EQUIPMENT	Refuse - Commercial	300 AND 400 CONTAINERS	\$14,390.00
AMERI-TECH EQUIPMENT	Refuse - Commercial	2 AND 3 YD BINS	\$10,979.30
AMERI-TECH EQUIPMENT	Refuse - Commercial	300 AND 400 CONTAINERS	\$572.00
<i>AMERI-TECH EQUIPMENT - Total For Refuse - Commercial</i>			\$25,941.30
AMERI-TECH EQUIPMENT	Refuse - Recycling	cap. lift eq. recycle containers	\$1,584.52
<i>AMERI-TECH EQUIPMENT - Total For Refuse - Recycling</i>			\$1,584.52
AMERI-TECH EQUIPMENT - ALL DEPARTMENTS			\$29,522.14

AMZN Mktp US

AMZN Mktp US	Aquatics - Pool	Bio Hazard Bins for Outdoor Pools	\$48.50
AMZN Mktp US	Aquatics - Pool	Pool Valve and Bio Hazard Bags	\$88.67
<i>AMZN Mktp US - Total For Aquatics - Pool</i>			\$137.17
AMZN Mktp US	City Council	BOOK STORES	\$138.00
AMZN Mktp US	City Council	Amazon - Refund for Sales Tax for Thermometer	(\$19.80)
<i>AMZN Mktp US - Total For City Council</i>			\$118.20
AMZN Mktp US	Fire-EMS Administration	Dry erase board and supplies	\$22.58
<i>AMZN Mktp US - Total For Fire-EMS Administration</i>			\$22.58
AMZN Mktp US	Municipal Court	COVID Supplies, Tape and Pens	\$58.26
AMZN Mktp US	Municipal Court	Incorrect Card Used, reversal issued and will foll	\$28.85
AMZN Mktp US	Municipal Court	Wrong card used, reversal per conversation wit	(\$28.85)
<i>AMZN Mktp US - Total For Municipal Court</i>			\$58.26
AMZN Mktp US	Parks - Parks Maint.	Reservation sign holders for parks shelters	\$136.00

<i>AMZN Mktp US - Total For Parks - Parks Maint.</i>			<i>\$136.00</i>
AMZN Mktp US	Police Administration	ipad tripod case and screen protector	\$87.97
<i>AMZN Mktp US - Total For Police Administration</i>			<i>\$87.97</i>
AMZN Mktp US	Police Federal Grants	med kit supplies	\$55.96
AMZN Mktp US	Police Federal Grants	mpr bag for med kits	\$115.76
AMZN Mktp US	Police Federal Grants	med kit supplies	\$55.96
AMZN Mktp US	Police Federal Grants	med kit supplies	\$515.55
AMZN Mktp US	Police Federal Grants	med kit supplies	\$479.17
AMZN Mktp US	Police Federal Grants	fox chest seal for med kits	\$148.72
AMZN Mktp US	Police Federal Grants	primed gauze for med kits	\$193.50
AMZN Mktp US	Police Federal Grants	first aid waterproof tape	\$167.60
AMZN Mktp US	Police Federal Grants	celox blood clotting granule applicator	\$903.80
<i>AMZN Mktp US - Total For Police Federal Grants</i>			<i>\$2,636.02</i>
AMZN Mktp US - ALL DEPARTMENTS			\$3,196.20

APPLE COMPUTER, INC.

APPLE COMPUTER, INC.	Fire-EMS Administration	iCloud Storage	\$0.99
<i>APPLE COMPUTER, INC. - Total For Fire-EMS Administration</i>			<i>\$0.99</i>
APPLE COMPUTER, INC.	Fire-EMS Training	SimsUshare App	\$0.65
<i>APPLE COMPUTER, INC. - Total For Fire-EMS Training</i>			<i>\$0.65</i>
APPLE COMPUTER, INC. - ALL DEPARTMENTS			\$1.64

ARCHITECTURALGLAZING

ARCHITECTURALGLAZING	Capital Projects Fund	Overhead Door - Install Doors and Windows at	\$1,283.00
<i>ARCHITECTURALGLAZING - Total For Capital Projects Fund</i>			<i>\$1,283.00</i>
ARCHITECTURALGLAZING - ALL DEPARTMENTS			\$1,283.00

ARROWHEAD HEATING

ARROWHEAD HEATING	WWTP Operations	HEATING, PLUMBING, AIR CONDITIONING CONT	\$872.60
<i>ARROWHEAD HEATING - Total For WWTP Operations</i>			<i>\$872.60</i>
ARROWHEAD HEATING - ALL DEPARTMENTS			\$872.60

AT&T BILL PAYMENT

AT&T BILL PAYMENT	Sewer Wastewater Collection remote device data		\$120.12
<i>AT&T BILL PAYMENT - Total For Sewer Wastewater Collection</i>			\$120.12
AT&T BILL PAYMENT	Water Distribution	TELECOMMUNICATION SERV.INCLUD. LOCAL/L.	\$160.16
<i>AT&T BILL PAYMENT - Total For Water Distribution</i>			\$160.16
AT&T BILL PAYMENT - ALL DEPARTMENTS			\$280.28

ATLANTIC ELECTRIC, I

ATLANTIC ELECTRIC, I	Balefill - Disposal & Landfill	Light cold storage welder room	\$273.52
<i>ATLANTIC ELECTRIC, I - Total For Balefill - Disposal & Landfill</i>			\$273.52
ATLANTIC ELECTRIC, I	Traffic Control	FY20 Luminaire Services 16-008	\$13,786.53
<i>ATLANTIC ELECTRIC, I - Total For Traffic Control</i>			\$13,786.53
ATLANTIC ELECTRIC, I - ALL DEPARTMENTS			\$14,060.05

ATLAS OFFICE PRODUCT

ATLAS OFFICE PRODUCT	Balefill - Disposal & Landfill	ink	\$101.79
ATLAS OFFICE PRODUCT	Balefill - Disposal & Landfill	Ink	\$896.16
<i>ATLAS OFFICE PRODUCT - Total For Balefill - Disposal & Landfill</i>			\$997.95
ATLAS OFFICE PRODUCT	City Attorney	COMMERCIAL EQUIPMENT, NOT ELSEWHERE CL	\$68.45
ATLAS OFFICE PRODUCT	City Attorney	COMMERCIAL EQUIPMENT, NOT ELSEWHERE CL	\$71.89
<i>ATLAS OFFICE PRODUCT - Total For City Attorney</i>			\$140.34
ATLAS OFFICE PRODUCT	Customer Service	COFFEE	\$25.98
ATLAS OFFICE PRODUCT	Customer Service	Customer Serv. Disinfecting Wipes	\$54.12
ATLAS OFFICE PRODUCT	Customer Service	CUSTOMER SERVICE WIRELESS MOUSE	\$33.00
ATLAS OFFICE PRODUCT	Customer Service	INFORMATION DESK CARTRIDGE	\$106.23
<i>ATLAS OFFICE PRODUCT - Total For Customer Service</i>			\$219.33
ATLAS OFFICE PRODUCT	Engineering	BR & Office supplies	\$78.73
ATLAS OFFICE PRODUCT	Engineering	BR supplies	\$11.83
<i>ATLAS OFFICE PRODUCT - Total For Engineering</i>			\$90.56
ATLAS OFFICE PRODUCT	Fire-EMS Administration	Ink Cartridges	\$197.46
ATLAS OFFICE PRODUCT	Fire-EMS Administration	Ink Cartridges	\$95.16
<i>ATLAS OFFICE PRODUCT - Total For Fire-EMS Administration</i>			\$292.62
ATLAS OFFICE PRODUCT	Ft. Caspar Museum	Office supplies; some for Covid-19 precautions	\$21.01
<i>ATLAS OFFICE PRODUCT - Total For Ft. Caspar Museum</i>			\$21.01
ATLAS OFFICE PRODUCT	Human Resources	1 pack standard size paper clips	\$8.78

ATLAS OFFICE PRODUCT	Human Resources	2 monthly file folders, fasteners for personnel fi	\$31.75
<i>ATLAS OFFICE PRODUCT - Total For Human Resources</i>			<i>\$40.53</i>
ATLAS OFFICE PRODUCT	Information Services	Batteries, key rack	\$51.15
<i>ATLAS OFFICE PRODUCT - Total For Information Services</i>			<i>\$51.15</i>
ATLAS OFFICE PRODUCT	Municipal Court	Paper	\$267.92
<i>ATLAS OFFICE PRODUCT - Total For Municipal Court</i>			<i>\$267.92</i>
ATLAS OFFICE PRODUCT	Planning	COVERS FOR BINDING	\$30.70
ATLAS OFFICE PRODUCT	Planning	LABELS	\$8.99
<i>ATLAS OFFICE PRODUCT - Total For Planning</i>			<i>\$39.69</i>
ATLAS OFFICE PRODUCT	Police Administration	misc supplies	\$142.82
ATLAS OFFICE PRODUCT	Police Administration	post it notes	\$15.55
<i>ATLAS OFFICE PRODUCT - Total For Police Administration</i>			<i>\$158.37</i>
ATLAS OFFICE PRODUCT	Public Safety Communication	Ink	\$227.25
ATLAS OFFICE PRODUCT	Public Safety Communication	Ink	\$227.25
<i>ATLAS OFFICE PRODUCT - Total For Public Safety Communications</i>			<i>\$454.50</i>
ATLAS OFFICE PRODUCT	Regional Water Operations	office	\$21.24
ATLAS OFFICE PRODUCT	Regional Water Operations	office supplies	\$1,388.84
ATLAS OFFICE PRODUCT	Regional Water Operations	Office Supply	\$114.18
<i>ATLAS OFFICE PRODUCT - Total For Regional Water Operations</i>			<i>\$1,524.26</i>
ATLAS OFFICE PRODUCT	Sewer Administration	Office Supplies	\$37.34
ATLAS OFFICE PRODUCT	Sewer Administration	White board	\$26.02
<i>ATLAS OFFICE PRODUCT - Total For Sewer Administration</i>			<i>\$63.36</i>
ATLAS OFFICE PRODUCT	Sewer Wastewater Collection	office supplies	\$88.08
<i>ATLAS OFFICE PRODUCT - Total For Sewer Wastewater Collection</i>			<i>\$88.08</i>
ATLAS OFFICE PRODUCT	Water Administration	White board	\$31.79
ATLAS OFFICE PRODUCT	Water Administration	Office Supplies	\$45.63
<i>ATLAS OFFICE PRODUCT - Total For Water Administration</i>			<i>\$77.42</i>
ATLAS OFFICE PRODUCT - ALL DEPARTMENTS			\$4,527.09

AUDIMATION

AUDIMATION	Finance	IDEA Software maintenance	\$3,550.00
<i>AUDIMATION - Total For Finance</i>			<i>\$3,550.00</i>
AUDIMATION - ALL DEPARTMENTS			\$3,550.00

B32 ENGINEERING GROU

B32 ENGINEERING GROU	Capital Projects Fund	CIA chiller replacement 15-58	\$1,505.78
<i>B32 ENGINEERING GROU - Total For Capital Projects Fund</i>			<i>\$1,505.78</i>
B32 ENGINEERING GROU - ALL DEPARTMENTS			\$1,505.78

BADGER METER INC

BADGER METER INC	Meter Services	Orion cellular	\$161.98
<i>BADGER METER INC - Total For Meter Services</i>			<i>\$161.98</i>
BADGER METER INC - ALL DEPARTMENTS			\$161.98

BAILEY'S ACE HARDWAR

BAILEY'S ACE HARDWAR	Refuse - Residential	padlock, spraypaint	\$100.41
<i>BAILEY'S ACE HARDWAR - Total For Refuse - Residential</i>			<i>\$100.41</i>
BAILEY'S ACE HARDWAR - ALL DEPARTMENTS			\$100.41

BAILEYS ACE HDWE

BAILEYS ACE HDWE	Aquatics - Pool	Wrench to repair faucet seats	\$7.99
<i>BAILEYS ACE HDWE - Total For Aquatics - Pool</i>			<i>\$7.99</i>
BAILEYS ACE HDWE	Buildings & Structures Fund	Supplies to install toilet partitions at Golf Cour	\$30.94
<i>BAILEYS ACE HDWE - Total For Buildings & Structures Fund</i>			<i>\$30.94</i>
BAILEYS ACE HDWE	Fire-EMS Operations	Hose Nozzle, Utility Lighter, Tube Heat Shrink	\$21.96
<i>BAILEYS ACE HDWE - Total For Fire-EMS Operations</i>			<i>\$21.96</i>
BAILEYS ACE HDWE	Meter Services	Parts for a map gas torch	\$38.97
<i>BAILEYS ACE HDWE - Total For Meter Services</i>			<i>\$38.97</i>
BAILEYS ACE HDWE	Parks - Athletic Maint.	Keys for Lights at softball fields	\$11.95
<i>BAILEYS ACE HDWE - Total For Parks - Athletic Maint.</i>			<i>\$11.95</i>
BAILEYS ACE HDWE	Parks - Parks Maint.	Caulk for monument at Veterans Park	\$13.58
<i>BAILEYS ACE HDWE - Total For Parks - Parks Maint.</i>			<i>\$13.58</i>
BAILEYS ACE HDWE	Sewer Wastewater Collection	shop tools	\$9.58
<i>BAILEYS ACE HDWE - Total For Sewer Wastewater Collection</i>			<i>\$9.58</i>
BAILEYS ACE HDWE	Traffic Control	Replacement pliers for signal repairs	\$26.99
<i>BAILEYS ACE HDWE - Total For Traffic Control</i>			<i>\$26.99</i>
BAILEYS ACE HDWE	WWTP Operations	Gas can	\$12.99

BAILEYS ACE HDWE	WWTP Operations	Sprinkler lock box	\$5.99
<i>BAILEYS ACE HDWE - Total For WWTP Operations</i>			<i>\$18.98</i>
BAILEYS ACE HDWE - ALL DEPARTMENTS			\$180.94

BARGREEN ELLINGSON

BARGREEN ELLINGSON	Golf - Operations	supplies	\$80.52
BARGREEN ELLINGSON	Golf - Operations	36 Oak Street Bar Stools	\$4,462.92
BARGREEN ELLINGSON	Golf - Operations	Invoices 009478438, 39, 32, 37, 36	\$26,198.66
BARGREEN ELLINGSON	Golf - Operations	Supplies	\$152.70
<i>BARGREEN ELLINGSON - Total For Golf - Operations</i>			<i>\$30,894.80</i>
BARGREEN ELLINGSON - ALL DEPARTMENTS			\$30,894.80

BARGREEN WYOMING

BARGREEN WYOMING	Aquatics - Pool	Cleaning Supplies for outdoor pools	\$95.60
<i>BARGREEN WYOMING - Total For Aquatics - Pool</i>			<i>\$95.60</i>
BARGREEN WYOMING	Golf - Operations	Paper towels and Toilet paper for on course bat	\$163.14
BARGREEN WYOMING	Golf - Operations	Casters for fridge	\$137.78
<i>BARGREEN WYOMING - Total For Golf - Operations</i>			<i>\$300.92</i>
BARGREEN WYOMING - ALL DEPARTMENTS			\$396.52

BEACON ATHLETICS

BEACON ATHLETICS	Parks - Athletic Maint.	Base Anchor Dig out Tools	\$152.46
<i>BEACON ATHLETICS - Total For Parks - Athletic Maint.</i>			<i>\$152.46</i>
BEACON ATHLETICS - ALL DEPARTMENTS			\$152.46

BECKER ARENA

BECKER ARENA	Ice Arena - Classes	Goal Netting for Game Nets	\$525.55
<i>BECKER ARENA - Total For Ice Arena - Classes</i>			<i>\$525.55</i>
BECKER ARENA - ALL DEPARTMENTS			\$525.55

BEST BUY

BEST BUY	Water Administration	ELECTRONIC SALES	\$59.99
----------	----------------------	------------------	---------

BEST BUY - Total For Water Administration \$59.99

BEST BUY - ALL DEPARTMENTS \$59.99

BEST VALUE COPY

BEST VALUE COPY Aquatics - Aquatics Classes Training Manuals \$267.11

BEST VALUE COPY - Total For Aquatics - Aquatics Classes \$267.11

BEST VALUE COPY - ALL DEPARTMENTS \$267.11

BESTBUYCOM8060826751

BESTBUYCOM8060826751 Fire-EMS Prevent & Inspect Tablet Case and Screen Printer \$120.73

BESTBUYCOM8060826751 - Total For Fire-EMS Prevent & Inspect \$120.73

BESTBUYCOM8060826751 - ALL DEPARTMENTS \$120.73

BESTBUYCOM8061046594

BESTBUYCOM8061046594 Fire-EMS Operations 6' USB to HDMI Cable \$26.24

BESTBUYCOM8061046594 - Total For Fire-EMS Operations \$26.24

BESTBUYCOM8061046594 - ALL DEPARTMENTS \$26.24

BESTBUYCOM8061267340

BESTBUYCOM8061267340 Information Services Macbook Pro for MDM Configurations and man \$1,199.99

BESTBUYCOM8061267340 Information Services Lightning to USB-C Cable for Macbook Pro MD \$19.99

BESTBUYCOM8061267340 - Total For Information Services \$1,219.98

BESTBUYCOM8061267340 - ALL DEPARTMENTS \$1,219.98

BLACK HILLS ENERGY

BLACK HILLS ENERGY Aquatics - Operations acct. 7584 6122 74 \$2,749.59

BLACK HILLS ENERGY - Total For Aquatics - Operations \$2,749.59

BLACK HILLS ENERGY Aquatics - Pool acct. 9723 1946 06 \$357.00

BLACK HILLS ENERGY - Total For Aquatics - Pool \$357.00

BLACK HILLS ENERGY Balefill - Disposal & Landfill Gas ldf remediation acct. 7538 8605 37 \$29.00

BLACK HILLS ENERGY Balefill - Disposal & Landfill acct. 1919 8530 97 \$1,051.12

BLACK HILLS ENERGY - Total For Balefill - Disposal & Landfill \$1,080.12

BLACK HILLS ENERGY	Buildings & Structures Fund	acct. 8545 6521 02	\$95.47
<i>BLACK HILLS ENERGY - Total For Buildings & Structures Fund</i>			\$95.47
BLACK HILLS ENERGY	Cemetery	acct. 9629 0042 60	\$62.51
<i>BLACK HILLS ENERGY - Total For Cemetery</i>			\$62.51
BLACK HILLS ENERGY	City Center Building	acct. 8545 6521 02	\$57.18
<i>BLACK HILLS ENERGY - Total For City Center Building</i>			\$57.18
BLACK HILLS ENERGY	City Hall	acct. 6837 4281 65	\$895.06
<i>BLACK HILLS ENERGY - Total For City Hall</i>			\$895.06
BLACK HILLS ENERGY	Fire-EMS Administration	Acct. 1783 9430 41	\$513.82
BLACK HILLS ENERGY	Fire-EMS Administration	acct. 3267 4234 58	\$77.03
<i>BLACK HILLS ENERGY - Total For Fire-EMS Administration</i>			\$590.85
BLACK HILLS ENERGY	Fleet Maintenance Fund	acct. 5293 6421 13	\$923.22
<i>BLACK HILLS ENERGY - Total For Fleet Maintenance Fund</i>			\$923.22
BLACK HILLS ENERGY	Ft. Caspar Museum	acct. 9861 5264 23	\$198.07
<i>BLACK HILLS ENERGY - Total For Ft. Caspar Museum</i>			\$198.07
BLACK HILLS ENERGY	Golf - Operations	acct. 6566 7661 30	\$106.80
BLACK HILLS ENERGY	Golf - Operations	acct. 1340 9824 25	\$25.98
<i>BLACK HILLS ENERGY - Total For Golf - Operations</i>			\$132.78
BLACK HILLS ENERGY	Ice Arena - Operations	acct. 9570 6006 61	\$206.45
<i>BLACK HILLS ENERGY - Total For Ice Arena - Operations</i>			\$206.45
BLACK HILLS ENERGY	Marathon Building	acct. 8545 6521 02	\$139.37
<i>BLACK HILLS ENERGY - Total For Marathon Building</i>			\$139.37
BLACK HILLS ENERGY	Metro Animal Shelter	acct. 9630 2229 58	\$536.10
<i>BLACK HILLS ENERGY - Total For Metro Animal Shelter</i>			\$536.10
BLACK HILLS ENERGY	Miller St. Dormitory	acct. 8545 6521 02	\$21.10
<i>BLACK HILLS ENERGY - Total For Miller St. Dormitory</i>			\$21.10
BLACK HILLS ENERGY	Parks - Parks Maint.	acct. 2076 2356 87	\$98.34
<i>BLACK HILLS ENERGY - Total For Parks - Parks Maint.</i>			\$98.34
BLACK HILLS ENERGY	Rec Center - Operations	acct. 4400 2150 46	\$736.29
<i>BLACK HILLS ENERGY - Total For Rec Center - Operations</i>			\$736.29
BLACK HILLS ENERGY	Regional Water Operations	Gas acct.7513 1659 94	\$2,171.68
<i>BLACK HILLS ENERGY - Total For Regional Water Operations</i>			\$2,171.68
BLACK HILLS ENERGY	Sewer Wastewater Collection	acct. 6405 5357 61	\$32.24
<i>BLACK HILLS ENERGY - Total For Sewer Wastewater Collection</i>			\$32.24
BLACK HILLS ENERGY	WWTP Operations	acct. 5541 2887 44	\$2,057.36
<i>BLACK HILLS ENERGY - Total For WWTP Operations</i>			\$2,057.36

BLACK HILLS ENERGY - ALL DEPARTMENTS**\$13,140.78****BLACK IRISH BOOKS**

BLACK IRISH BOOKS	Police Administration	book for training	\$201.03
-------------------	-----------------------	-------------------	----------

<i>BLACK IRISH BOOKS - Total For Police Administration</i>			<i>\$201.03</i>
--	--	--	-----------------

BLACK IRISH BOOKS - ALL DEPARTMENTS**\$201.03****BLOEDORN LUMBER**

BLOEDORN LUMBER	Balefill - Disposal & Landfill	miller house knife, carpet tape	\$26.97
-----------------	--------------------------------	---------------------------------	---------

<i>BLOEDORN LUMBER - Total For Balefill - Disposal & Landfill</i>			<i>\$26.97</i>
---	--	--	----------------

BLOEDORN LUMBER	Buildings & Structures Fund	City hall wedge bit	\$22.90
-----------------	-----------------------------	---------------------	---------

BLOEDORN LUMBER	Buildings & Structures Fund	Padlocks	\$265.20
-----------------	-----------------------------	----------	----------

BLOEDORN LUMBER	Buildings & Structures Fund	rotary hammer	\$656.28
-----------------	-----------------------------	---------------	----------

BLOEDORN LUMBER	Buildings & Structures Fund	ft. caspar supplies	\$30.35
-----------------	-----------------------------	---------------------	---------

BLOEDORN LUMBER	Buildings & Structures Fund	north casper club house supplies	\$24.72
-----------------	-----------------------------	----------------------------------	---------

<i>BLOEDORN LUMBER - Total For Buildings & Structures Fund</i>			<i>\$999.45</i>
--	--	--	-----------------

BLOEDORN LUMBER - ALL DEPARTMENTS**\$1,026.42****BLOEDORN LUMBER CASP**

BLOEDORN LUMBER CASP	Property Insurance Fund	posts for soccer complex damage	\$145.65
----------------------	-------------------------	---------------------------------	----------

<i>BLOEDORN LUMBER CASP - Total For Property Insurance Fund</i>			<i>\$145.65</i>
---	--	--	-----------------

BLOEDORN LUMBER CASP	WWTP Regional Interceptors	Quikcrete	\$10.00
----------------------	----------------------------	-----------	---------

<i>BLOEDORN LUMBER CASP - Total For WWTP Regional Interceptors</i>			<i>\$10.00</i>
--	--	--	----------------

BLOEDORN LUMBER CASP - ALL DEPARTMENTS**\$155.65****BRECK MEDIA GROUP WY**

BRECK MEDIA GROUP WY	Parks - Special Areas	ADVERTISING SERVICES	\$500.00
----------------------	-----------------------	----------------------	----------

BRECK MEDIA GROUP WY	Parks - Special Areas	ADVERTISING SERVICES	\$96.00
----------------------	-----------------------	----------------------	---------

<i>BRECK MEDIA GROUP WY - Total For Parks - Special Areas</i>			<i>\$596.00</i>
---	--	--	-----------------

BRECK MEDIA GROUP WY - ALL DEPARTMENTS**\$596.00****BRENNTAG PACIFIC, IN**

BRENNTAG PACIFIC, IN	Regional Water Operations	Ferric	\$9,991.60
BRENNTAG PACIFIC, IN	Regional Water Operations	Ferric	\$9,974.00
BRENNTAG PACIFIC, IN	Regional Water Operations	Ferric	\$9,846.40
BRENNTAG PACIFIC, IN	Regional Water Operations	Ferric	\$10,114.80
BRENNTAG PACIFIC, IN	Regional Water Operations	Ferric	\$9,886.00
BRENNTAG PACIFIC, IN	Regional Water Operations	Ferric	\$10,026.80
BRENNTAG PACIFIC, IN	Regional Water Operations	Ferric	\$9,828.80
<i>BRENNTAG PACIFIC, IN - Total For Regional Water Operations</i>			<i>\$69,668.40</i>
BRENNTAG PACIFIC, IN - ALL DEPARTMENTS			\$69,668.40

BRUCE HEBERLEIN

BRUCE HEBERLEIN	Golf - Operations	install vinyl wall covering	\$350.00
<i>BRUCE HEBERLEIN - Total For Golf - Operations</i>			<i>\$350.00</i>
BRUCE HEBERLEIN - ALL DEPARTMENTS			\$350.00

BURBACKS

BURBACKS	Buildings & Structures Fund	Ice machine parts	\$308.99
<i>BURBACKS - Total For Buildings & Structures Fund</i>			<i>\$308.99</i>
BURBACKS - ALL DEPARTMENTS			\$308.99

CARUS CORPORATION

CARUS CORPORATION	Regional Water Operations	PHI 500 Acti-Flo Polymer	\$8,964.00
CARUS CORPORATION	Regional Water Operations	PHI 500 Acti Flo Polymer	\$8,964.00
<i>CARUS CORPORATION - Total For Regional Water Operations</i>			<i>\$17,928.00</i>
CARUS CORPORATION - ALL DEPARTMENTS			\$17,928.00

CASPER AREA TRANSPOR

CASPER AREA TRANSPOR	CATC - CARES Act	May 2020 cares act expenses	107,905.91
<i>CASPER AREA TRANSPOR - Total For CATC - CARES Act</i>			<i>\$107,905.91</i>
CASPER AREA TRANSPOR	CATC - Operations	May 2020 operating assistance	\$862.71
CASPER AREA TRANSPOR	CATC - Operations	May 2020 emergency relief	\$29,393.08
<i>CASPER AREA TRANSPOR - Total For CATC - Operations</i>			<i>\$30,255.79</i>

CASPER AREA TRANSPOR - ALL DEPARTMENTS**\$138,161.70****CASPER COLLEGE**

CASPER COLLEGE	Hogadon - Operations	Classrooms for Outdoor Emergency classes for	\$350.00
----------------	----------------------	--	----------

<i>CASPER COLLEGE - Total For Hogadon - Operations</i>			<i>\$350.00</i>
--	--	--	-----------------

CASPER COLLEGE - ALL DEPARTMENTS			\$350.00
---	--	--	-----------------

CASPER CONTRACTORS S

CASPER CONTRACTORS S	Water Distribution	pin flags	\$42.66
----------------------	--------------------	-----------	---------

<i>CASPER CONTRACTORS S - Total For Water Distribution</i>			<i>\$42.66</i>
--	--	--	----------------

CASPER CONTRACTORS S - ALL DEPARTMENTS			\$42.66
---	--	--	----------------

CASPER ELECTRIC, INC

CASPER ELECTRIC, INC	Balefill - Disposal & Landfill	Air compressor hook up	\$153.11
----------------------	--------------------------------	------------------------	----------

<i>CASPER ELECTRIC, INC - Total For Balefill - Disposal & Landfill</i>			<i>\$153.11</i>
--	--	--	-----------------

CASPER ELECTRIC, INC	Capital Projects Fund	2020 Lighting replacement 19-057 retainage rel	\$10,111.25
----------------------	-----------------------	--	-------------

<i>CASPER ELECTRIC, INC - Total For Capital Projects Fund</i>			<i>\$10,111.25</i>
---	--	--	--------------------

CASPER ELECTRIC, INC - ALL DEPARTMENTS			\$10,264.36
---	--	--	--------------------

CASPER FIRE EXTINGUI

CASPER FIRE EXTINGUI	Golf - Operations	fire ext. refill	\$28.75
----------------------	-------------------	------------------	---------

<i>CASPER FIRE EXTINGUI - Total For Golf - Operations</i>			<i>\$28.75</i>
---	--	--	----------------

CASPER FIRE EXTINGUI	Streets	2020 Fire Ext. Annual Inspections, 6 Year, Recha	\$1,410.00
----------------------	---------	--	------------

<i>CASPER FIRE EXTINGUI - Total For Streets</i>			<i>\$1,410.00</i>
---	--	--	-------------------

CASPER FIRE EXTINGUI - ALL DEPARTMENTS			\$1,438.75
---	--	--	-------------------

CASPER STAR TRIBUNE

CASPER STAR TRIBUNE	City Clerk	NEWS DEALERS AND NEWSSTANDS	\$930.58
---------------------	------------	-----------------------------	----------

CASPER STAR TRIBUNE	City Clerk	NEWS DEALERS AND NEWSSTANDS	\$90.38
---------------------	------------	-----------------------------	---------

<i>CASPER STAR TRIBUNE - Total For City Clerk</i>			<i>\$1,020.96</i>
---	--	--	-------------------

CASPER STAR TRIBUNE	Regional Water Operations	Advertising	\$57.76
---------------------	---------------------------	-------------	---------

CASPER STAR TRIBUNE	Regional Water Operations	Advertising	\$98.84
---------------------	---------------------------	-------------	---------

CASPER STAR TRIBUNE - Total For Regional Water Operations \$156.60

CASPER STAR TRIBUNE - ALL DEPARTMENTS \$1,177.56

CASPER STAR-TRIBUNE,

CASPER STAR-TRIBUNE, Capital Projects Fund CEC Fencing final pay 19-066 \$208.90

CASPER STAR-TRIBUNE, - Total For Capital Projects Fund \$208.90

CASPER STAR-TRIBUNE, City Clerk Council minutes \$1,954.60

CASPER STAR-TRIBUNE, - Total For City Clerk \$1,954.60

CASPER STAR-TRIBUNE, Finance Notice of hearing \$56.12

CASPER STAR-TRIBUNE, Finance Notice of hearing \$57.56

CASPER STAR-TRIBUNE, - Total For Finance \$113.68

CASPER STAR-TRIBUNE, Metropolitan Planning Org Request for proposals lathrop \$93.56

CASPER STAR-TRIBUNE, Metropolitan Planning Org Mtio amendment upwp and dbe block ad \$395.00

CASPER STAR-TRIBUNE, - Total For Metropolitan Planning Org \$488.56

CASPER STAR-TRIBUNE, Perpetual Care Building Trust CEC arena floor lighting 19-014 \$213.64

CASPER STAR-TRIBUNE, - Total For Perpetual Care Building Trust \$213.64

CASPER STAR-TRIBUNE, Planning Corrected notice planning \$125.12

CASPER STAR-TRIBUNE, - Total For Planning \$125.12

CASPER STAR-TRIBUNE, Refuse - Residential Recycling Survey \$2,089.00

CASPER STAR-TRIBUNE, - Total For Refuse - Residential \$2,089.00

CASPER STAR-TRIBUNE, - ALL DEPARTMENTS \$5,193.50

CASPER TIRE

CASPER TIRE Refuse - Commercial 222284 flat \$150.00

CASPER TIRE Refuse - Commercial 222276 semi flat \$110.00

CASPER TIRE Refuse - Commercial 222287 semi flat \$180.00

CASPER TIRE Refuse - Commercial unit 2288 flat \$35.00

CASPER TIRE - Total For Refuse - Commercial \$475.00

CASPER TIRE - ALL DEPARTMENTS \$475.00

CASPER WINDOW AND DO

CASPER WINDOW AND DO Hogadon - Operations repair of the rental shop auto doors \$80.00

CASPER WINDOW AND DO - Total For Hogadon - Operations \$80.00

CASPER WINDOW AND DO - ALL DEPARTMENTS**\$80.00****CASPER WINNELSON CO**

CASPER WINNELSON CO	Buildings & Structures Fund	Isolation valve for Metro Animal Shelter	\$41.60
CASPER WINNELSON CO	Buildings & Structures Fund	Plumbing repair parts for City Hall restrooms	\$27.54
CASPER WINNELSON CO	Buildings & Structures Fund	Plumbing repair parts for Hogadon Lodge	\$88.00
CASPER WINNELSON CO	Buildings & Structures Fund	Plumbing repair and isolation valves for Metro	\$180.29
CASPER WINNELSON CO	Buildings & Structures Fund	Plumbing repair parts for Skeet Range	\$50.83
CASPER WINNELSON CO	Buildings & Structures Fund	Plumbing supply parts for Golf Course Clubhous	\$277.20
CASPER WINNELSON CO	Buildings & Structures Fund	Plumbing repair parts for Golf Course Clubhouse	\$184.21
CASPER WINNELSON CO	Buildings & Structures Fund	Plumbing repair parts for Skeet Range	\$99.52
CASPER WINNELSON CO	Buildings & Structures Fund	Plumbing repair parts for Parks work	\$67.73
CASPER WINNELSON CO	Buildings & Structures Fund	Plumbing repair parts for Golf Course Clubhouse	\$4.96
CASPER WINNELSON CO	Buildings & Structures Fund	Plumbing repair parts for Rec Center	\$27.40
CASPER WINNELSON CO	Buildings & Structures Fund	Plumbing repair parts for Golf Course Clubhouse	\$14.97
CASPER WINNELSON CO	Buildings & Structures Fund	Plumbing repair parts for Golf Course Clubhouse	\$52.60
CASPER WINNELSON CO	Buildings & Structures Fund	Plumbing repair parts for Golf Course Clubhouse	\$23.72
CASPER WINNELSON CO	Buildings & Structures Fund	Plumbing repair parts for Golf Course Clubhouse	\$32.70
CASPER WINNELSON CO	Buildings & Structures Fund	Plumbing repair parts for Golf Course Clubhouse	\$55.12
CASPER WINNELSON CO	Buildings & Structures Fund	Plumbing parts for Fire Station2	\$32.14
CASPER WINNELSON CO	Buildings & Structures Fund	BAS Shop Tools	\$89.60
<i>CASPER WINNELSON CO - Total For Buildings & Structures Fund</i>			<i>\$1,350.13</i>
CASPER WINNELSON CO	Capital Projects Fund	Water Spigot repair parts for Events Center	\$11.85
CASPER WINNELSON CO	Capital Projects Fund	Plumbing repair parts for Events Center	\$109.22
<i>CASPER WINNELSON CO - Total For Capital Projects Fund</i>			<i>\$121.07</i>
CASPER WINNELSON CO	Parks - Parks Maint.	Return of incorrect mixer valves	(\$95.97)
CASPER WINNELSON CO	Parks - Parks Maint.	Wrong Mixer valves at 19th hole that have since	\$95.97
<i>CASPER WINNELSON CO - Total For Parks - Parks Maint.</i>			<i>\$0.00</i>
CASPER WINNELSON CO	WWTP Operations	Hose repair parts	\$49.88
CASPER WINNELSON CO	WWTP Operations	Plumbing fittings	\$36.41
<i>CASPER WINNELSON CO - Total For WWTP Operations</i>			<i>\$86.29</i>
CASPER WINNELSON CO - ALL DEPARTMENTS			\$1,557.49

CDW GOVERNMENT, INC.

CDW GOVERNMENT, INC.	Capital Projects Fund	10 New Digital Persona Licenses	\$1,129.40
<i>CDW GOVERNMENT, INC. - Total For Capital Projects Fund</i>			<i>\$1,129.40</i>
CDW GOVERNMENT, INC. - ALL DEPARTMENTS			\$1,129.40

CENTRAL TRUCK & DIES

CENTRAL TRUCK & DIES	WWTP Operations	Shop tools	\$84.15
<i>CENTRAL TRUCK & DIES - Total For WWTP Operations</i>			<i>\$84.15</i>
CENTRAL TRUCK & DIES - ALL DEPARTMENTS			\$84.15

CENTURYLINK

CENTURYLINK	Aquatics - Pool	acct. 307-235-8494 223B	\$127.48
<i>CENTURYLINK - Total For Aquatics - Pool</i>			<i>\$127.48</i>
CENTURYLINK	Metro Animal Shelter	Phone use p-307-234-8116 403M	\$154.58
<i>CENTURYLINK - Total For Metro Animal Shelter</i>			<i>\$154.58</i>
CENTURYLINK	Sewer Wastewater Collection	Phone use acct. 307-472-1129 839B	\$45.65
<i>CENTURYLINK - Total For Sewer Wastewater Collection</i>			<i>\$45.65</i>
CENTURYLINK - ALL DEPARTMENTS			\$327.71

CHEWY.COM

CHEWY.COM	Metro Animal Shelter	bacus animal food	\$197.95
<i>CHEWY.COM - Total For Metro Animal Shelter</i>			<i>\$197.95</i>
CHEWY.COM - ALL DEPARTMENTS			\$197.95

CHEYENNE CITY TREASU

CHEYENNE CITY TREASU	Police Administration	Swat overtime June 5-6, acct. 15060	\$2,100.76
<i>CHEYENNE CITY TREASU - Total For Police Administration</i>			<i>\$2,100.76</i>
CHEYENNE CITY TREASU - ALL DEPARTMENTS			\$2,100.76

CITIZEN PAYMENT

CITIZEN PAYMENT	Aquatics - Aquatics Classes	Lifeguard class	\$160.00
<i>CITIZEN PAYMENT - Total For Aquatics - Aquatics Classes</i>			<i>\$160.00</i>
CITIZEN PAYMENT	Refuse - Commercial	Refund for services not provided	\$1,513.50

<i>CITIZEN PAYMENT - Total For Refuse - Commercial</i>			\$1,513.50
CITIZEN PAYMENT - ALL DEPARTMENTS			\$1,673.50

CITY OF CASPER

CITY OF CASPER	Buildings & Structures Fund	Balefill	\$284.04
<i>CITY OF CASPER - Total For Buildings & Structures Fund</i>			\$284.04
CITY OF CASPER	CATC - CARES Act	May 2020 fuel charges	\$6,125.15
CITY OF CASPER	CATC - CARES Act	May 2020 workorders	\$3,021.38
<i>CITY OF CASPER - Total For CATC - CARES Act</i>			\$9,146.53
CITY OF CASPER	Hogadon - Operations	Balefill	\$22.44
<i>CITY OF CASPER - Total For Hogadon - Operations</i>			\$22.44
CITY OF CASPER	Ice Arena - Concessions	Yearly health license	\$100.00
<i>CITY OF CASPER - Total For Ice Arena - Concessions</i>			\$100.00
CITY OF CASPER	Metropolitan Planning Org	June 2020 GIS service	\$6,211.87
CITY OF CASPER	Metropolitan Planning Org	Quarterly GIS support April-June	\$1,283.66
<i>CITY OF CASPER - Total For Metropolitan Planning Org</i>			\$7,495.53
CITY OF CASPER	Parks - Parks Maint.	Balefill	\$95.00
<i>CITY OF CASPER - Total For Parks - Parks Maint.</i>			\$95.00
CITY OF CASPER	Refuse - Residential	Balefill	\$7,176.72
CITY OF CASPER	Refuse - Residential	Balefill	\$7,273.26
CITY OF CASPER	Refuse - Residential	Balefill	\$7,778.52
CITY OF CASPER	Refuse - Residential	Balefill	\$45,375.00
CITY OF CASPER	Refuse - Residential	Balefill	\$6,916.62
CITY OF CASPER	Refuse - Residential	Balefill	\$7,256.07
CITY OF CASPER	Refuse - Residential	Balefill	\$7,683.66
CITY OF CASPER	Refuse - Residential	Balefill	\$6,669.93
<i>CITY OF CASPER - Total For Refuse - Residential</i>			\$96,129.78
CITY OF CASPER	Regional Water Operations	Balefill	\$18.00
CITY OF CASPER	Regional Water Operations	Balefill	\$18.00
CITY OF CASPER	Regional Water Operations	Balefill	\$54.00
CITY OF CASPER	Regional Water Operations	Utilities acct. 1910101	\$24.33
CITY OF CASPER	Regional Water Operations	Utilities acct. 1910101	\$124.50
CITY OF CASPER	Regional Water Operations	Balefill	\$18.00
<i>CITY OF CASPER - Total For Regional Water Operations</i>			\$256.83
CITY OF CASPER	WWTP Operations	Balefill	\$258.06

CITY OF CASPER	WWTP Operations	Balefill	\$129.03
CITY OF CASPER	WWTP Operations	Balefill	\$118.83
CITY OF CASPER	WWTP Operations	Balefill	\$75.99

CITY OF CASPER - Total For WWTP Operations \$581.91

CITY OF CASPER - ALL DEPARTMENTS **\$114,112.06**

CIVIL ENGINEERING PR

CIVIL ENGINEERING PR	Sewer Wastewater Collection Poplar and 1st street 17-072		\$1,661.86
----------------------	--	--	------------

CIVIL ENGINEERING PR - Total For Sewer Wastewater Collection \$1,661.86

CIVIL ENGINEERING PR	Water Distribution	Poplar and 1st street 17-072	\$930.64
----------------------	--------------------	------------------------------	----------

CIVIL ENGINEERING PR	Water Distribution	New water system master plan f	\$5,580.00
----------------------	--------------------	--------------------------------	------------

CIVIL ENGINEERING PR - Total For Water Distribution \$6,510.64

CIVIL ENGINEERING PR	Water Tanks	CY booster station	\$15,362.50
----------------------	-------------	--------------------	-------------

CIVIL ENGINEERING PR - Total For Water Tanks \$15,362.50

CIVIL ENGINEERING PR - ALL DEPARTMENTS **\$23,535.00**

CMI TECO, INC.

CMI TECO, INC.	Refuse - Commercial	222285 repairs	\$262.11
----------------	---------------------	----------------	----------

CMI TECO, INC.	Refuse - Commercial	222283 repairs	\$2,870.75
----------------	---------------------	----------------	------------

CMI TECO, INC.	Refuse - Commercial	222261 repairs	\$1,829.56
----------------	---------------------	----------------	------------

CMI TECO, INC.	Refuse - Commercial	222285 repairs	\$576.11
----------------	---------------------	----------------	----------

CMI TECO, INC.	Refuse - Commercial	222247 repairs	\$4,644.33
----------------	---------------------	----------------	------------

CMI TECO, INC.	Refuse - Commercial	222283 repairs	\$948.99
----------------	---------------------	----------------	----------

CMI TECO, INC.	Refuse - Commercial	222289 repairs	\$329.40
----------------	---------------------	----------------	----------

CMI TECO, INC.	Refuse - Commercial	222262 repairs	\$7,504.50
----------------	---------------------	----------------	------------

CMI TECO, INC.	Refuse - Commercial	222276 repairs	\$1,369.95
----------------	---------------------	----------------	------------

CMI TECO, INC.	Refuse - Commercial	222299 repairs	\$98.00
----------------	---------------------	----------------	---------

CMI TECO, INC.	Refuse - Commercial	222276 repairs	\$932.89
----------------	---------------------	----------------	----------

CMI TECO, INC.	Refuse - Commercial	222275 repairs	\$4,166.56
----------------	---------------------	----------------	------------

CMI TECO, INC.	Refuse - Commercial	222283 repairs	\$1,793.32
----------------	---------------------	----------------	------------

CMI TECO, INC.	Refuse - Commercial	222288 repairs	\$17.66
----------------	---------------------	----------------	---------

CMI TECO, INC.	Refuse - Commercial	222289 repairs	\$118.49
----------------	---------------------	----------------	----------

CMI TECO, INC.	Refuse - Commercial	222273 repairs	\$3,384.40
----------------	---------------------	----------------	------------

CMI TECO, INC.	Refuse - Commercial	2273 pack cylinders	\$10,362.77
----------------	---------------------	---------------------	-------------

CMI TECO, INC.	Refuse - Commercial	222272 repairs	\$306.73
CMI TECO, INC.	Refuse - Commercial	222275 repairs	\$191.86
CMI TECO, INC.	Refuse - Commercial	222271 repairs	\$1,212.25
CMI TECO, INC.	Refuse - Commercial	222263 repairs	\$3,806.15
CMI TECO, INC.	Refuse - Commercial	222284 repairs	\$2,707.04
CMI TECO, INC.	Refuse - Commercial	222261 repairs	\$1,381.65
CMI TECO, INC.	Refuse - Commercial	222274 repairs	\$5,625.03
CMI TECO, INC.	Refuse - Commercial	222257 repairs	\$766.38
CMI TECO, INC.	Refuse - Commercial	222255 repairs	\$1,626.58
CMI TECO, INC.	Refuse - Commercial	222261 repairs	\$1,335.20
CMI TECO, INC.	Refuse - Commercial	222286 repairs	\$3,041.85
CMI TECO, INC.	Refuse - Commercial	222272 repairs	\$667.88
CMI TECO, INC.	Refuse - Commercial	222261 Repairs	\$781.43
CMI TECO, INC.	Refuse - Commercial	222247 repairs	\$250.78
CMI TECO, INC.	Refuse - Commercial	Labor credit	(\$1,350.00)
CMI TECO, INC.	Refuse - Commercial	222283 repairs	\$241.96

CMI TECO, INC. - Total For Refuse - Commercial \$63,802.56

CMI TECO, INC. - ALL DEPARTMENTS **\$63,802.56**

COASTAL CHEMICAL CO

COASTAL CHEMICAL CO	Regional Water Operations	Vehicle Gas	\$90.16
COASTAL CHEMICAL CO	Regional Water Operations	Vehicle Fuel	\$70.04

COASTAL CHEMICAL CO - Total For Regional Water Operations \$160.20

COASTAL CHEMICAL CO - ALL DEPARTMENTS **\$160.20**

COCA COLA BOTTLING C

COCA COLA BOTTLING C	Balefill - Disposal & Landfill	WATER IN SCALEHOUSE FOR CUSTOMERS	\$39.50
----------------------	--------------------------------	-----------------------------------	---------

COCA COLA BOTTLING C - Total For Balefill - Disposal & Landfill \$39.50

COCA COLA BOTTLING C - ALL DEPARTMENTS **\$39.50**

CODALE ELECTRIC-CASP

CODALE ELECTRIC-CASP	Regional Water Operations	Lighting contactor for Settled Water	\$866.00
----------------------	---------------------------	--------------------------------------	----------

CODALE ELECTRIC-CASP - Total For Regional Water Operations \$866.00

CODALE ELECTRIC-CASP - ALL DEPARTMENTS**\$866.00****COLLECTION CENTER IN**

COLLECTION CENTER IN	Refuse - Residential	Commission	\$306.95
<i>COLLECTION CENTER IN - Total For Refuse - Residential</i>			<i>\$306.95</i>
COLLECTION CENTER IN	Sewer Administration	Commission	\$233.28
<i>COLLECTION CENTER IN - Total For Sewer Administration</i>			<i>\$233.28</i>
COLLECTION CENTER IN	Water Administration	Commission	\$687.57
<i>COLLECTION CENTER IN - Total For Water Administration</i>			<i>\$687.57</i>

COLLECTION CENTER IN - ALL DEPARTMENTS**\$1,227.80****COMMUNICATION TECHNO**

COMMUNICATION TECHNO	Balefill - Diversion & Special	fix radio	\$51.50
<i>COMMUNICATION TECHNO - Total For Balefill - Diversion & Special</i>			<i>\$51.50</i>
COMMUNICATION TECHNO	Capital Projects Fund	Motorcycle equipment installs	\$5,817.00
COMMUNICATION TECHNO	Capital Projects Fund	Purchase and installation of equipment by Com	\$18,080.58
COMMUNICATION TECHNO	Capital Projects Fund	Purchase and installation of equipment by Com	\$28,045.70
COMMUNICATION TECHNO	Capital Projects Fund	Purchase and installation of equipment by Com	\$3,000.00
<i>COMMUNICATION TECHNO - Total For Capital Projects Fund</i>			<i>\$54,943.28</i>
COMMUNICATION TECHNO	Fire-EMS Operations	Repair of ground loop at St. 5	\$206.00
<i>COMMUNICATION TECHNO - Total For Fire-EMS Operations</i>			<i>\$206.00</i>
COMMUNICATION TECHNO	Police Administration	unit 219 gunlock	\$91.50
COMMUNICATION TECHNO	Police Administration	100 amp breaker	\$138.00
<i>COMMUNICATION TECHNO - Total For Police Administration</i>			<i>\$229.50</i>
COMMUNICATION TECHNO	Property Insurance Fund	ELECTRICAL PARTS AND EQUIPMENT	\$515.00
COMMUNICATION TECHNO	Property Insurance Fund	ELECTRICAL PARTS AND EQUIPMENT	\$184.47
<i>COMMUNICATION TECHNO - Total For Property Insurance Fund</i>			<i>\$699.47</i>
COMMUNICATION TECHNO	Public Safety Communication	License fee for ais	\$49,995.00
<i>COMMUNICATION TECHNO - Total For Public Safety Communications</i>			<i>\$49,995.00</i>

COMMUNICATION TECHNO - ALL DEPARTMENTS**\$106,124.75****COMPRESSION LEASING**

COMPRESSION LEASING	Balefill - Disposal & Landfill	Labor	\$157.50
---------------------	--------------------------------	-------	----------

COMPRESSION LEASING	Balefill - Disposal & Landfill	Labor	\$210.00
<i>COMPRESSION LEASING - Total For Balefill - Disposal & Landfill</i>			<i>\$367.50</i>
COMPRESSION LEASING - ALL DEPARTMENTS			\$367.50

COMTRONIX, INC.

COMTRONIX, INC.	Aquatics - Operations	ALARM MONITORING	\$165.00
<i>COMTRONIX, INC. - Total For Aquatics - Operations</i>			<i>\$165.00</i>
COMTRONIX, INC.	Balefill - Disposal & Landfill	alarm monitoring	\$1,068.00
<i>COMTRONIX, INC. - Total For Balefill - Disposal & Landfill</i>			<i>\$1,068.00</i>
COMTRONIX, INC.	Balefill - Diversion & Special	Labor e-waste bldg	\$1,240.56
<i>COMTRONIX, INC. - Total For Balefill - Diversion & Special</i>			<i>\$1,240.56</i>
COMTRONIX, INC.	Ft. Caspar Museum	Quarterly alarm monitoring for museum and for	\$531.00
<i>COMTRONIX, INC. - Total For Ft. Caspar Museum</i>			<i>\$531.00</i>
COMTRONIX, INC.	Hogadon - Operations	Fire alarm monitoring	\$183.00
<i>COMTRONIX, INC. - Total For Hogadon - Operations</i>			<i>\$183.00</i>
COMTRONIX, INC.	Ice Arena - Operations	ALARM MONITORING	\$108.00
<i>COMTRONIX, INC. - Total For Ice Arena - Operations</i>			<i>\$108.00</i>
COMTRONIX, INC.	Rec Center - Admin	ALARM MONITORING	\$108.00
<i>COMTRONIX, INC. - Total For Rec Center - Admin</i>			<i>\$108.00</i>
COMTRONIX, INC.	Rec Center - Operations	BUSINESS SERVICES NOT ELSEWHERE CLASSIFI	\$472.14
<i>COMTRONIX, INC. - Total For Rec Center - Operations</i>			<i>\$472.14</i>
COMTRONIX, INC. - ALL DEPARTMENTS			\$3,875.70

CONVERGEONE

CONVERGEONE	Golf - Operations	2 head set for golf shop	\$535.08
<i>CONVERGEONE - Total For Golf - Operations</i>			<i>\$535.08</i>
CONVERGEONE	Police Administration	smartnet add	\$10.00
<i>CONVERGEONE - Total For Police Administration</i>			<i>\$10.00</i>
CONVERGEONE	Public Safety Communication	Viper system	\$59,577.54
<i>CONVERGEONE - Total For Public Safety Communications</i>			<i>\$59,577.54</i>
CONVERGEONE - ALL DEPARTMENTS			\$60,122.62

COPPERLEAF CUSTOM BU

COPPERLEAF CUSTOM BU	Golf - Operations	19th hole removal	\$22,069.95
<i>COPPERLEAF CUSTOM BU - Total For Golf - Operations</i>			<i>\$22,069.95</i>
COPPERLEAF CUSTOM BU - ALL DEPARTMENTS			\$22,069.95

Core & Main

Core & Main	Water Revenue and Transfer	200 meter seals	\$38.00
Core & Main	Water Revenue and Transfer	One 1.5 inch ecoder	\$534.70
Core & Main	Water Revenue and Transfer	Eight 5/8 inch E-Coders	\$889.60
Core & Main	Water Revenue and Transfer	Seven e-coders	\$803.30
<i>Core & Main - Total For Water Revenue and Transfers</i>			<i>\$2,265.60</i>
Core & Main - ALL DEPARTMENTS			\$2,265.60

CORO MEDICAL LLC

CORO MEDICAL LLC	Aquatics - Pool	AED Pads	\$208.00
<i>CORO MEDICAL LLC - Total For Aquatics - Pool</i>			<i>\$208.00</i>
CORO MEDICAL LLC - ALL DEPARTMENTS			\$208.00

CPS DISTRIBUTORS

CPS DISTRIBUTORS	Capital Projects Fund	Irrigation repair 10th & Missouri	\$12.97
CPS DISTRIBUTORS	Capital Projects Fund	Stock purchase of heads for park replacements	\$328.89
CPS DISTRIBUTORS	Capital Projects Fund	New controller for Metro Animal Control	\$117.33
CPS DISTRIBUTORS	Capital Projects Fund	Nozzles and Controllers for Irrigation to 2nd Str	\$240.10
<i>CPS DISTRIBUTORS - Total For Capital Projects Fund</i>			<i>\$699.29</i>
CPS DISTRIBUTORS	Water Distribution	Repair parts for sprinkler repair	\$5.90
<i>CPS DISTRIBUTORS - Total For Water Distribution</i>			<i>\$5.90</i>
CPS DISTRIBUTORS	Weed & Pest Fund	Irrigation heads for Athletic Fields	\$271.04
<i>CPS DISTRIBUTORS - Total For Weed & Pest Fund</i>			<i>\$271.04</i>
CPS DISTRIBUTORS - ALL DEPARTMENTS			\$976.23

CPU IIT

CPU IIT	Balefill - Disposal & Landfill	SWM18 Replacement Laptop Landfill Supervisor	\$1,166.00
CPU IIT	Balefill - Disposal & Landfill	SWM15 Replacement-Special Waste Supervisor	\$950.40
<i>CPU IIT - Total For Balefill - Disposal & Landfill</i>			<i>\$2,116.40</i>

CPU IIT	Capital Projects Fund	Server Room UPS Replacement with PDU	\$6,164.85
<i>CPU IIT - Total For Capital Projects Fund</i>			<i>\$6,164.85</i>
CPU IIT	City Attorney	ELECTRONIC SALES	\$598.00
<i>CPU IIT - Total For City Attorney</i>			<i>\$598.00</i>
CPU IIT	Engineering	WEB CAM FOR A.BEAMER	\$169.00
<i>CPU IIT - Total For Engineering</i>			<i>\$169.00</i>
CPU IIT	Fire-EMS Administration	Technology Items (computers, software, and ne	\$1,635.00
CPU IIT	Fire-EMS Administration	logitech webcam	\$436.00
CPU IIT	Fire-EMS Administration	HP Elite X2 13" Touchscreen 2 in 1 \$1,494.00	\$2,160.00
CPU IIT	Fire-EMS Administration	Panasonic tbook	\$2,139.00
<i>CPU IIT - Total For Fire-EMS Administration</i>			<i>\$6,370.00</i>
CPU IIT	Golf - Operations	Laptop, Dock, 2 Monitors, Printer for Golf Pro	\$419.00
<i>CPU IIT - Total For Golf - Operations</i>			<i>\$419.00</i>
CPU IIT	Information Services	ELECTRONIC SALES	\$757.00
CPU IIT	Information Services	Technology Items (computers, software, and ne	\$1,557.40
CPU IIT	Information Services	ELECTRONIC SALES	\$56.40
<i>CPU IIT - Total For Information Services</i>			<i>\$2,370.80</i>
CPU IIT	Municipal Court	3 Fujitsu ScanSnap S1300i Portable Color Docu	\$897.00
<i>CPU IIT - Total For Municipal Court</i>			<i>\$897.00</i>
CPU IIT	Planning	HP USB DOCKING STATION	\$179.00
<i>CPU IIT - Total For Planning</i>			<i>\$179.00</i>
CPU IIT	Refuse - Residential	SWM17 Computer Replacement-Admin Tech	\$950.40
<i>CPU IIT - Total For Refuse - Residential</i>			<i>\$950.40</i>
CPU IIT	Water Administration	Technology Items (computers, software, and ne	\$1,563.00
<i>CPU IIT - Total For Water Administration</i>			<i>\$1,563.00</i>
CPU IIT - ALL DEPARTMENTS			\$21,797.45

CRIME SCENE INFORMAT

CRIME SCENE INFORMAT	Police Administration	July 2020	\$109.87
<i>CRIME SCENE INFORMAT - Total For Police Administration</i>			<i>\$109.87</i>
CRIME SCENE INFORMAT - ALL DEPARTMENTS			\$109.87

CRUM ELECTRIC SUPPLY

CRUM ELECTRIC SUPPLY	Regional Water Operations	ELECTRICAL PARTS AND EQUIPMENT	\$11.84
----------------------	---------------------------	--------------------------------	---------

CRUM ELECTRIC SUPPLY	Regional Water Operations	Front Gate Repair	\$57.84
<i>CRUM ELECTRIC SUPPLY - Total For Regional Water Operations</i>			<i>\$69.68</i>
CRUM ELECTRIC SUPPLY	RWS - Booster Stations	Pioneer Booster Pump	\$23.27
<i>CRUM ELECTRIC SUPPLY - Total For RWS - Booster Stations</i>			<i>\$23.27</i>
CRUM ELECTRIC SUPPLY	Traffic Control	Fuses for 2nd & Beverly, 12th & Beverly , 2nd &	\$203.84
<i>CRUM ELECTRIC SUPPLY - Total For Traffic Control</i>			<i>\$203.84</i>
CRUM ELECTRIC SUPPLY	Water Tanks	ELECTRICAL PARTS AND EQUIPMENT	\$7.30
CRUM ELECTRIC SUPPLY	Water Tanks	ELECTRICAL PARTS AND EQUIPMENT FOR MTN.	\$103.07
<i>CRUM ELECTRIC SUPPLY - Total For Water Tanks</i>			<i>\$110.37</i>
CRUM ELECTRIC SUPPLY	WWTP Operations	Soft start	\$1,120.77
CRUM ELECTRIC SUPPLY	WWTP Operations	Controller buttons	\$141.97
<i>CRUM ELECTRIC SUPPLY - Total For WWTP Operations</i>			<i>\$1,262.74</i>
CRUM ELECTRIC SUPPLY - ALL DEPARTMENTS			\$1,669.90

CS CONSULTING

CS CONSULTING	Balefill - Diversion & Special	Incident investigation	\$600.00
<i>CS CONSULTING - Total For Balefill - Diversion & Special</i>			<i>\$600.00</i>
CS CONSULTING - ALL DEPARTMENTS			\$600.00

Cunningham Electric

Cunningham Electric	Golf - Operations	Lighting and installation	\$9,525.00
<i>Cunningham Electric - Total For Golf - Operations</i>			<i>\$9,525.00</i>
Cunningham Electric - ALL DEPARTMENTS			\$9,525.00

CYNTHIA MILLAY

CYNTHIA MILLAY	Parks - Parks Maint.	Traffic wrap art	\$200.00
<i>CYNTHIA MILLAY - Total For Parks - Parks Maint.</i>			<i>\$200.00</i>
CYNTHIA MILLAY - ALL DEPARTMENTS			\$200.00

DAKOTA FENCE COMPANY

DAKOTA FENCE COMPANY	Traffic Control	New cones for striping operation.	\$1,073.00
DAKOTA FENCE COMPANY	Traffic Control	5 gallon pail of P50 glue for inlaid striping inst	\$385.22
DAKOTA FENCE COMPANY	Traffic Control	Sign blanks for mast arm street signs.	\$492.85

<i>DAKOTA FENCE COMPANY - Total For Traffic Control</i>			<i>\$1,951.07</i>
DAKOTA FENCE COMPANY - ALL DEPARTMENTS			\$1,951.07

DAVIDSON MECHANICAL,

DAVIDSON MECHANICAL,	Golf - Operations	Install dishwasher,sinks, fauc	\$2,750.00
<i>DAVIDSON MECHANICAL, - Total For Golf - Operations</i>			<i>\$2,750.00</i>
DAVIDSON MECHANICAL,	Parks - Special Areas	Install dishwasher,sinks, fauc	\$648.78
<i>DAVIDSON MECHANICAL, - Total For Parks - Special Areas</i>			<i>\$648.78</i>
DAVIDSON MECHANICAL, - ALL DEPARTMENTS			\$3,398.78

DBC IRRIGATION SUPPL

DBC IRRIGATION SUPPL	Capital Projects Fund	Nozzles for Irrigation 2nd Street Planters	\$222.53
DBC IRRIGATION SUPPL	Capital Projects Fund	Stock PVB Parts	\$80.07
DBC IRRIGATION SUPPL	Capital Projects Fund	Irrigation repair 2nd & Washington	\$37.81
DBC IRRIGATION SUPPL	Capital Projects Fund	RP Repair parts for irrigation on Center Street	\$180.11
DBC IRRIGATION SUPPL	Capital Projects Fund	Irrigation repair Event Center	\$111.87
DBC IRRIGATION SUPPL	Capital Projects Fund	Node controllers for Irrigation to 2nd Street Pla	\$113.72
DBC IRRIGATION SUPPL	Capital Projects Fund	Irrigation repair for 2nd Street Planters	\$63.26
DBC IRRIGATION SUPPL	Capital Projects Fund	Irrigation repair State Building	\$62.62
DBC IRRIGATION SUPPL	Capital Projects Fund	Irrigation repair Aquatic Center	\$38.56
<i>DBC IRRIGATION SUPPL - Total For Capital Projects Fund</i>			<i>\$910.55</i>
DBC IRRIGATION SUPPL	Parks - Athletic Maint.	Irrigation heads for the Soccer Field	\$756.80
<i>DBC IRRIGATION SUPPL - Total For Parks - Athletic Maint.</i>			<i>\$756.80</i>
DBC IRRIGATION SUPPL	Parks - Parks Maint.	Irrigation repair Susie McMuury	\$1.26
<i>DBC IRRIGATION SUPPL - Total For Parks - Parks Maint.</i>			<i>\$1.26</i>
DBC IRRIGATION SUPPL	Weed & Pest Fund	INDUSTRIAL SUPPLIES NOT ESLEWHERE CLASSI	\$76.67
DBC IRRIGATION SUPPL	Weed & Pest Fund	Athletics Irrigation	\$440.85
<i>DBC IRRIGATION SUPPL - Total For Weed & Pest Fund</i>			<i>\$517.52</i>
DBC IRRIGATION SUPPL - ALL DEPARTMENTS			\$2,186.13

DECKER AUTO GLASS, I

DECKER AUTO GLASS, I	Fleet Maintenance Fund	101201 repairs	\$306.59
<i>DECKER AUTO GLASS, I - Total For Fleet Maintenance Fund</i>			<i>\$306.59</i>

DECKER AUTO GLASS, I - ALL DEPARTMENTS**\$306.59****DELL MARKETING LP**

DELL MARKETING LP	Balefill - Disposal & Landfill	VLA OFFICE PRO PLUS 2019 FOR THREE (3) COM	\$760.20
<i>DELL MARKETING LP - Total For Balefill - Disposal & Landfill</i>			<i>\$760.20</i>
DELL MARKETING LP	City Attorney	Adobe Pro DC for Ken Marken's Computer	\$45.38
<i>DELL MARKETING LP - Total For City Attorney</i>			<i>\$45.38</i>
DELL MARKETING LP	Finance	Adobe Pro for Pete Meyers	\$45.38
<i>DELL MARKETING LP - Total For Finance</i>			<i>\$45.38</i>
DELL MARKETING LP	Fire-EMS Administration	Technology Items (computers, software, and ne	\$380.08
DELL MARKETING LP	Fire-EMS Administration	HP Elite X2 13" Touchscreen 2 in 1 \$1,494.00	\$380.08
<i>DELL MARKETING LP - Total For Fire-EMS Administration</i>			<i>\$760.16</i>
DELL MARKETING LP	Golf - Operations	Laptop, Dock, 2 Monitors, Printer for Golf Pro	\$380.08
<i>DELL MARKETING LP - Total For Golf - Operations</i>			<i>\$380.08</i>
DELL MARKETING LP	Information Services	VLA Azure Overage Reconciliation through June	\$269.02
<i>DELL MARKETING LP - Total For Information Services</i>			<i>\$269.02</i>
DELL MARKETING LP	Police Administration	purchase VLA office pro plus x 3	\$376.28
DELL MARKETING LP	Police Administration	purchase VLA office pro plus x 3	\$763.96
<i>DELL MARKETING LP - Total For Police Administration</i>			<i>\$1,140.24</i>
DELL MARKETING LP	Refuse - Residential	VLA OFFICE PRO PLUS 2019 FOR THREE (3) COM	\$380.04
<i>DELL MARKETING LP - Total For Refuse - Residential</i>			<i>\$380.04</i>
DELL MARKETING LP	Water Distribution	Technology Items (computers, software, and ne	\$380.08
<i>DELL MARKETING LP - Total For Water Distribution</i>			<i>\$380.08</i>

DELL MARKETING LP - ALL DEPARTMENTS**\$4,160.58****DENNIS SUPPLY CO.**

DENNIS SUPPLY CO.	Buildings & Structures Fund	acid quick check	\$13.72
DENNIS SUPPLY CO.	Buildings & Structures Fund	air filter	\$33.65
DENNIS SUPPLY CO.	Buildings & Structures Fund	valve, hose	\$156.12
DENNIS SUPPLY CO.	Buildings & Structures Fund	calgon nickel safe clnr	\$59.09
DENNIS SUPPLY CO.	Buildings & Structures Fund	round run capacitor	\$8.60
<i>DENNIS SUPPLY CO. - Total For Buildings & Structures Fund</i>			<i>\$271.18</i>
DENNIS SUPPLY CO.	Capital Projects Fund	rbm relay	\$7.65
DENNIS SUPPLY CO.	Capital Projects Fund	Pleated air filter	\$35.40

DENNIS SUPPLY CO.	Capital Projects Fund	Short paid invoice	\$0.33
DENNIS SUPPLY CO.	Capital Projects Fund	gas, chuck driver	\$203.78
<i>DENNIS SUPPLY CO. - Total For Capital Projects Fund</i>			<i>\$247.16</i>
DENNIS SUPPLY CO. - ALL DEPARTMENTS			\$518.34

DEPT. OF FAMILY SVCS

DEPT. OF FAMILY SVCS	Ice Arena - Concessions	State Wyoming Renewal - Concession Food Lice	\$50.00
<i>DEPT. OF FAMILY SVCS - Total For Ice Arena - Concessions</i>			<i>\$50.00</i>
DEPT. OF FAMILY SVCS - ALL DEPARTMENTS			\$50.00

DEWALD MASONRY

DEWALD MASONRY	Property Insurance Fund	Claim 2964CA- repair planter	\$475.00
<i>DEWALD MASONRY - Total For Property Insurance Fund</i>			<i>\$475.00</i>
DEWALD MASONRY - ALL DEPARTMENTS			\$475.00

DEWITT WATER SYSTEMS

DEWITT WATER SYSTEMS	Municipal Court	Water Contract	\$33.40
<i>DEWITT WATER SYSTEMS - Total For Municipal Court</i>			<i>\$33.40</i>
DEWITT WATER SYSTEMS - ALL DEPARTMENTS			\$33.40

DIAMOND VOGEL PAINTS

DIAMOND VOGEL PAINTS	Buildings & Structures Fund	whip hose	\$9.00
DIAMOND VOGEL PAINTS	Buildings & Structures Fund	whip hose	\$23.00
DIAMOND VOGEL PAINTS	Buildings & Structures Fund	20" ext	\$42.10
<i>DIAMOND VOGEL PAINTS - Total For Buildings & Structures Fund</i>			<i>\$74.10</i>
DIAMOND VOGEL PAINTS - ALL DEPARTMENTS			\$74.10

DOLLAR TREE

DOLLAR TREE	Police Animal Control	animal treats	\$17.80
<i>DOLLAR TREE - Total For Police Animal Control</i>			<i>\$17.80</i>
DOLLAR TREE	Rec Center - Classes	VARIETY STORES	\$59.00
<i>DOLLAR TREE - Total For Rec Center - Classes</i>			<i>\$59.00</i>

DOLLAR TREE - ALL DEPARTMENTS **\$76.80**

DOOLEY OIL, INC.

DOOLEY OIL, INC.	Fleet Maintenance Fund	stock 02/CGF	\$14,250.17
DOOLEY OIL, INC.	Fleet Maintenance Fund	Stock 02/CGF	\$14,653.29

DOOLEY OIL, INC. - Total For Fleet Maintenance Fund *\$28,903.46*

DOOLEY OIL, INC. - ALL DEPARTMENTS **\$28,903.46**

DOORWAYS OF WYOMING

DOORWAYS OF WYOMING	Water Tanks	Supplies for Water Department Wind Blocks	\$500.00
---------------------	-------------	---	----------

DOORWAYS OF WYOMING - Total For Water Tanks *\$500.00*

DOORWAYS OF WYOMING - ALL DEPARTMENTS **\$500.00**

DPC INDUSTRIES, INC.

DPC INDUSTRIES, INC.	Regional Water Operations	NaHypo	\$7,593.73
DPC INDUSTRIES, INC.	Regional Water Operations	NaHypo	\$7,720.52
DPC INDUSTRIES, INC.	Regional Water Operations	NaHypo	\$7,637.69

DPC INDUSTRIES, INC. - Total For Regional Water Operations *\$22,951.94*

DPC INDUSTRIES, INC. - ALL DEPARTMENTS **\$22,951.94**

DXP ENTERPRISES, INC

DXP ENTERPRISES, INC	Regional Water Operations	Repair Corrosion Inhibitor pump motor	\$472.65
----------------------	---------------------------	---------------------------------------	----------

DXP ENTERPRISES, INC - Total For Regional Water Operations *\$472.65*

DXP ENTERPRISES, INC - ALL DEPARTMENTS **\$472.65**

E 470 EXPRESS TOLLS

E 470 EXPRESS TOLLS	Streets	TOLL CHARGES FOR 2020 ROCKY MTN ASPHALT	\$14.30
---------------------	---------	---	---------

E 470 EXPRESS TOLLS - Total For Streets *\$14.30*

E 470 EXPRESS TOLLS - ALL DEPARTMENTS **\$14.30**

EB 2020 WYOMING ACTI

EB 2020 WYOMING ACTI	Engineering	REFUND FOR REGISTRATION TO 2020 WYOMIN	(\$297.00)
<i>EB 2020 WYOMING ACTI - Total For Engineering</i>			<i>(\$297.00)</i>
EB 2020 WYOMING ACTI - ALL DEPARTMENTS			(\$297.00)

EMPLOYEE REIMBURSEME

EMPLOYEE REIMBURSEME	Balefill - Disposal & Landfill	Boot reimbursement	\$113.39
EMPLOYEE REIMBURSEME	Balefill - Disposal & Landfill	Clothing allowance	\$105.96
<i>EMPLOYEE REIMBURSEME - Total For Balefill - Disposal & Landfill</i>			<i>\$219.35</i>
EMPLOYEE REIMBURSEME	Balefill - Diversion & Special	Boot reimbursement	\$143.21
<i>EMPLOYEE REIMBURSEME - Total For Balefill - Diversion & Special</i>			<i>\$143.21</i>
EMPLOYEE REIMBURSEME	Fleet Maintenance Fund	Tool allotment	\$217.25
<i>EMPLOYEE REIMBURSEME - Total For Fleet Maintenance Fund</i>			<i>\$217.25</i>
EMPLOYEE REIMBURSEME	Health Insurance Fund	allstate refund	\$107.30
<i>EMPLOYEE REIMBURSEME - Total For Health Insurance Fund</i>			<i>\$107.30</i>
EMPLOYEE REIMBURSEME	Parks - Parks Maint.	Clothing allowance	\$89.22
<i>EMPLOYEE REIMBURSEME - Total For Parks - Parks Maint.</i>			<i>\$89.22</i>
EMPLOYEE REIMBURSEME	Planning	Rotary fees reimbursement	\$68.00
<i>EMPLOYEE REIMBURSEME - Total For Planning</i>			<i>\$68.00</i>
EMPLOYEE REIMBURSEME	Refuse - Residential	Boot allowance	\$138.59
<i>EMPLOYEE REIMBURSEME - Total For Refuse - Residential</i>			<i>\$138.59</i>
EMPLOYEE REIMBURSEME	Regional Water Operations	Boot, uniform reimbursement	\$150.00
EMPLOYEE REIMBURSEME	Regional Water Operations	Pants	\$60.06
EMPLOYEE REIMBURSEME	Regional Water Operations	Clothing Allowance	\$100.00
EMPLOYEE REIMBURSEME	Regional Water Operations	Boot, uniform reimbursement	\$39.94
<i>EMPLOYEE REIMBURSEME - Total For Regional Water Operations</i>			<i>\$350.00</i>
EMPLOYEE REIMBURSEME	Water Meters	Clothing allowance	\$43.85
EMPLOYEE REIMBURSEME	Water Meters	Clothing allowance	\$100.00
EMPLOYEE REIMBURSEME	Water Meters	Clothing allowance	\$83.82
EMPLOYEE REIMBURSEME	Water Meters	Clothing allowance	\$86.87
EMPLOYEE REIMBURSEME	Water Meters	Clothing allowance	\$99.28
<i>EMPLOYEE REIMBURSEME - Total For Water Meters</i>			<i>\$413.82</i>
EMPLOYEE REIMBURSEME	Water Tanks	Clothing allowance	\$81.33
EMPLOYEE REIMBURSEME	Water Tanks	Boot reimbursement	\$128.32
<i>EMPLOYEE REIMBURSEME - Total For Water Tanks</i>			<i>\$209.65</i>
EMPLOYEE REIMBURSEME	WWTP Operations	Boot reimbursement	\$142.79

EMPLOYEE REIMBURSEME - Total For WWTP Operations

\$142.79

EMPLOYEE REIMBURSEME - ALL DEPARTMENTS

\$2,099.18

ENERGY LABORATORIES

ENERGY LABORATORIES Hogadon - Operations monthly water testing \$22.00

ENERGY LABORATORIES - Total For Hogadon - Operations \$22.00

ENERGY LABORATORIES Regional Water Operations Lab Test TAS \$231.00

ENERGY LABORATORIES Regional Water Operations Lab Test TAS \$231.00

ENERGY LABORATORIES Regional Water Operations Lab Test Well Mix \$57.00

ENERGY LABORATORIES Regional Water Operations Lab Test TOC/ALK \$84.00

ENERGY LABORATORIES Regional Water Operations Lab Test TAS \$231.00

ENERGY LABORATORIES Regional Water Operations Lab Test NPDES Permit \$22.00

ENERGY LABORATORIES - Total For Regional Water Operations \$856.00

ENERGY LABORATORIES Water Tanks TESTING \$54.00

ENERGY LABORATORIES Water Tanks TESTING \$162.00

ENERGY LABORATORIES Water Tanks TESTING \$352.00

ENERGY LABORATORIES Water Tanks TESTING \$52.00

ENERGY LABORATORIES Water Tanks TESTING \$27.00

ENERGY LABORATORIES Water Tanks TESTING \$27.00

ENERGY LABORATORIES Water Tanks TESTING \$27.00

ENERGY LABORATORIES Water Tanks TESTING \$374.00

ENERGY LABORATORIES Water Tanks TESTING \$27.00

ENERGY LABORATORIES Water Tanks TESTING \$22.00

ENERGY LABORATORIES Water Tanks TESTING \$324.00

ENERGY LABORATORIES Water Tanks TESTING \$27.00

ENERGY LABORATORIES Water Tanks TESTING \$162.00

ENERGY LABORATORIES - Total For Water Tanks \$1,637.00

ENERGY LABORATORIES - ALL DEPARTMENTS

\$2,515.00

ENGINEERING DESIGN A

ENGINEERING DESIGN A Capital Projects Fund HVAC Design/CA at Aquatics 19-049 \$375.00

ENGINEERING DESIGN A Capital Projects Fund Design of Athletic Fields Light 20-018 \$937.50

ENGINEERING DESIGN A Capital Projects Fund Design - Metro Kennel HVAC \$60.00

ENGINEERING DESIGN A Capital Projects Fund Hogadon Air Conditioning Engin \$150.00

ENGINEERING DESIGN A - Total For Capital Projects Fund \$1,522.50

ENGINEERING DESIGN A - ALL DEPARTMENTS \$1,522.50

ENTENMANN-ROVIN COMP

ENTENMANN-ROVIN COMP Fire-EMS Operations Uniforms \$251.00

ENTENMANN-ROVIN COMP Fire-EMS Operations Badges and Engraving \$481.00

ENTENMANN-ROVIN COMP Fire-EMS Operations Badges and Engraving \$134.75

ENTENMANN-ROVIN COMP - Total For Fire-EMS Operations \$866.75

ENTENMANN-ROVIN COMP - ALL DEPARTMENTS \$866.75

ENVIRO-CLEAN GROUP

ENVIRO-CLEAN GROUP Risk Management Sewer Truck Silencer for Wastewater Collection \$3,749.50

ENVIRO-CLEAN GROUP - Total For Risk Management \$3,749.50

ENVIRO-CLEAN GROUP Sewer Wastewater Collection Sewer Truck Silencer for Wastewater Collection \$807.47

ENVIRO-CLEAN GROUP Sewer Wastewater Collection shipping for silencer \$165.00

ENVIRO-CLEAN GROUP - Total For Sewer Wastewater Collection \$972.47

ENVIRO-CLEAN GROUP - ALL DEPARTMENTS \$4,721.97

EPASALES

EPASALES Sewer Wastewater Collection cleaning nozzles \$680.19

EPASALES - Total For Sewer Wastewater Collection \$680.19

EPASALES - ALL DEPARTMENTS \$680.19

ETM

ETM Customer Service UPEXchange- Unclaimed Property Software for s \$79.00

ETM - Total For Customer Service \$79.00

ETM - ALL DEPARTMENTS \$79.00

EUROFINS EATON ANALY

EUROFINS EATON ANALY Regional Water Operations Lab Test Bromate \$200.00

EUROFINS EATON ANALY - Total For Regional Water Operations \$200.00

EUROFINS EATON ANALY - ALL DEPARTMENTS**\$200.00****EXXONMOBIL**

EXXONMOBIL	Fire-EMS Operations	Good 2 go - Fuel	\$40.57
EXXONMOBIL	Fire-EMS Operations	Good 2 Go - Fuel	\$22.72
EXXONMOBIL	Fire-EMS Operations	Good 2 Go - Fuel	\$26.73
EXXONMOBIL	Fire-EMS Operations	Good 2 Go - Fuel	\$27.43
EXXONMOBIL	Fire-EMS Operations	Good 2 Go - Fuel	\$57.21
EXXONMOBIL	Fire-EMS Operations	Good 2 Go - Fuel	\$24.99
EXXONMOBIL	Fire-EMS Operations	Fuel	\$28.94
EXXONMOBIL	Fire-EMS Operations	Good 2 Go	\$21.92

EXXONMOBIL - Total For Fire-EMS Operations \$250.51

EXXONMOBIL - ALL DEPARTMENTS**\$250.51****FACEBK F2E33VAKH2**

FACEBK F2E33VAKH2	Refuse - Residential	ADVERTISING SERVICES	\$86.95
-------------------	----------------------	----------------------	---------

FACEBK F2E33VAKH2 - Total For Refuse - Residential \$86.95

FACEBK F2E33VAKH2 - ALL DEPARTMENTS**\$86.95****FEDEX 393091394150**

FEDEX 393091394150	Fire-EMS Operations	Gear Repair Shipment	\$31.16
--------------------	---------------------	----------------------	---------

FEDEX 393091394150 - Total For Fire-EMS Operations \$31.16

FEDEX 393091394150 - ALL DEPARTMENTS**\$31.16****FEDEX 393091469346**

FEDEX 393091469346	Fire-EMS Operations	Gear Repair Shipment	\$14.15
--------------------	---------------------	----------------------	---------

FEDEX 393091469346 - Total For Fire-EMS Operations \$14.15

FEDEX 393091469346 - ALL DEPARTMENTS**\$14.15****FEDEX 93620637**

FEDEX 93620637	Police Administration	COURIER SERVICES-AIR OR GROUND,FREIGHT F	\$28.18
----------------	-----------------------	--	---------

FEDEX 93620637 - Total For Police Administration \$28.18

FEDEX 93620637 - ALL DEPARTMENTS**\$28.18****FEDEX 940487890631**

FEDEX 940487890631	Police Administration	COURIER SERVICES-AIR OR GROUND,FREIGHT F	\$2.99
--------------------	-----------------------	--	--------

<i>FEDEX 940487890631 - Total For Police Administration</i>			<i>\$2.99</i>
---	--	--	---------------

FEDEX 940487890631 - ALL DEPARTMENTS**\$2.99****FERGUSON ENTERPRISES**

FERGUSON ENTERPRISES	Buildings & Structures Fund	Supplies for Parks Irrigation System	\$124.78
----------------------	-----------------------------	--------------------------------------	----------

<i>FERGUSON ENTERPRISES - Total For Buildings & Structures Fund</i>			<i>\$124.78</i>
---	--	--	-----------------

FERGUSON ENTERPRISES	Parks - Parks Maint.	Water bottle fill station and fountain	\$1,050.00
----------------------	----------------------	--	------------

<i>FERGUSON ENTERPRISES - Total For Parks - Parks Maint.</i>			<i>\$1,050.00</i>
--	--	--	-------------------

FERGUSON ENTERPRISES	Regional Water Operations	Contactora drain valve	\$11,861.60
----------------------	---------------------------	------------------------	-------------

<i>FERGUSON ENTERPRISES - Total For Regional Water Operations</i>			<i>\$11,861.60</i>
---	--	--	--------------------

FERGUSON ENTERPRISES	Water Distribution	2020 CPU MATERIALS PROCUREMENT	\$6,966.05
----------------------	--------------------	--------------------------------	------------

<i>FERGUSON ENTERPRISES - Total For Water Distribution</i>			<i>\$6,966.05</i>
--	--	--	-------------------

FERGUSON ENTERPRISES - ALL DEPARTMENTS**\$20,002.43****FIRST DATA MERCHANT**

FIRST DATA MERCHANT	Cemetery	May 2020 fee	\$19.95
---------------------	----------	--------------	---------

<i>FIRST DATA MERCHANT - Total For Cemetery</i>			<i>\$19.95</i>
---	--	--	----------------

FIRST DATA MERCHANT	Hogadon - Admin	April 2020	\$4.15
---------------------	-----------------	------------	--------

<i>FIRST DATA MERCHANT - Total For Hogadon - Admin</i>			<i>\$4.15</i>
--	--	--	---------------

FIRST DATA MERCHANT - ALL DEPARTMENTS**\$24.10****FIRST INTERSTATE BAN**

FIRST INTERSTATE BAN	Finance	Service charges may 2020	\$5,587.84
----------------------	---------	--------------------------	------------

<i>FIRST INTERSTATE BAN - Total For Finance</i>			<i>\$5,587.84</i>
---	--	--	-------------------

FIRST INTERSTATE BAN	Human Resources	Gift cards	\$247.00
----------------------	-----------------	------------	----------

<i>FIRST INTERSTATE BAN - Total For Human Resources</i>			<i>\$247.00</i>
---	--	--	-----------------

FIRST INTERSTATE BAN - ALL DEPARTMENTS**\$5,834.84**

Fiverr

Fiverr	Police Administration	graphic design for recruitment video	\$29.00
<i>Fiverr - Total For Police Administration</i>			<i>\$29.00</i>
Fiverr - ALL DEPARTMENTS			\$29.00

FOREFLIGHT LLC

FOREFLIGHT LLC	Fire-EMS Administration	Basic Plus 1 Year Membership	\$99.99
FOREFLIGHT LLC	Fire-EMS Administration	Basic Plus 1 Year Membership	\$99.99
FOREFLIGHT LLC	Fire-EMS Administration	Basic Plus 1 Year Membership Credit	(\$99.99)
FOREFLIGHT LLC	Fire-EMS Administration	Basic Plus 1 Year Membership Credit	(\$99.99)
<i>FOREFLIGHT LLC - Total For Fire-EMS Administration</i>			<i>\$0.00</i>
FOREFLIGHT LLC - ALL DEPARTMENTS			\$0.00

FRONTIER PRECISION I

FRONTIER PRECISION I	Water Distribution	Trimble R1 GNSS receiver/antenna	\$1,985.00
<i>FRONTIER PRECISION I - Total For Water Distribution</i>			<i>\$1,985.00</i>
FRONTIER PRECISION I - ALL DEPARTMENTS			\$1,985.00

FULL COMPASS SYSTEMS

FULL COMPASS SYSTEMS	Golf - Operations	Microphone and amp	\$414.98
<i>FULL COMPASS SYSTEMS - Total For Golf - Operations</i>			<i>\$414.98</i>
FULL COMPASS SYSTEMS - ALL DEPARTMENTS			\$414.98

GALLS, INC.

GALLS, INC.	Police Administration	Patroltek Liner Belt	\$68.40
GALLS, INC.	Police Administration	Point blank mc guardian	\$526.50
GALLS, INC.	Police Administration	Patroltek liner belt	\$17.10
GALLS, INC.	Police Administration	Patroltek liner belt	\$17.10
GALLS, INC.	Police Administration	Uniform short sleeve polo	\$54.00
GALLS, INC.	Police Administration	Uniform short sleeve	\$162.00
GALLS, INC.	Police Administration	tactical pant	\$54.00
GALLS, INC.	Police Administration	tactical pants	\$135.00

GALLS, INC.	Police Administration	tactical pants	\$81.00
GALLS, INC.	Police Administration	tactical pants	\$162.00
GALLS, INC.	Police Administration	Zip boot, tactical pants	\$152.96
<i>GALLS, INC. - Total For Police Administration</i>			<i>\$1,430.06</i>
GALLS, INC. - ALL DEPARTMENTS			\$1,430.06

GEORGE T SANDERS

GEORGE T SANDERS	Buildings & Structures Fund	Urinal replacement parts for City Hall	\$282.98
<i>GEORGE T SANDERS - Total For Buildings & Structures Fund</i>			<i>\$282.98</i>
GEORGE T SANDERS - ALL DEPARTMENTS			\$282.98

GEOSYNTEC CONSULTANT

GEOSYNTEC CONSULTANT	Balefill - Disposal & Landfill	CRL Monitoring	\$581.62
<i>GEOSYNTEC CONSULTANT - Total For Balefill - Disposal & Landfill</i>			<i>\$581.62</i>
GEOSYNTEC CONSULTANT - ALL DEPARTMENTS			\$581.62

GLOBAL EQUIPMENT COM

GLOBAL EQUIPMENT COM	Balefill - Disposal & Landfill	reusable cloth face masks	\$79.46
GLOBAL EQUIPMENT COM	Balefill - Disposal & Landfill	reusable cloth face masks	\$166.92
<i>GLOBAL EQUIPMENT COM - Total For Balefill - Disposal & Landfill</i>			<i>\$246.38</i>
GLOBAL EQUIPMENT COM - ALL DEPARTMENTS			\$246.38

GRAINGER, INC.

GRAINGER, INC.	Balefill - Disposal & Landfill	air reuglator	\$74.32
<i>GRAINGER, INC. - Total For Balefill - Disposal & Landfill</i>			<i>\$74.32</i>
GRAINGER, INC.	Golf - Operations	Floor drain grates for 19th Hole	\$66.00
<i>GRAINGER, INC. - Total For Golf - Operations</i>			<i>\$66.00</i>
GRAINGER, INC.	Water Tanks	V-BELT PULLEY FOR MTN. RD. BOOSTER ROOF V	\$16.20
<i>GRAINGER, INC. - Total For Water Tanks</i>			<i>\$16.20</i>
GRAINGER, INC. - ALL DEPARTMENTS			\$156.52

GREEN'S SEWER & DRAI

GREEN'S SEWER & DRAI	Parks - Special Areas	Toilet repair	\$285.00
<i>GREEN'S SEWER & DRAI - Total For Parks - Special Areas</i>			<i>\$285.00</i>
GREEN'S SEWER & DRAI - ALL DEPARTMENTS			\$285.00

GUNNERS METERS

GUNNERS METERS	Water Revenue and Transfer	Four 1.5 in Meters	\$1,232.00
<i>GUNNERS METERS - Total For Water Revenue and Transfers</i>			<i>\$1,232.00</i>
GUNNERS METERS - ALL DEPARTMENTS			\$1,232.00

GUS GLOBALSTAR USA

GUS GLOBALSTAR USA	Fire-EMS Administration	Chief Harshman Satellite Phone	\$1,241.97
<i>GUS GLOBALSTAR USA - Total For Fire-EMS Administration</i>			<i>\$1,241.97</i>
GUS GLOBALSTAR USA - ALL DEPARTMENTS			\$1,241.97

HAASS CONSTRUCTION C

HAASS CONSTRUCTION C	Capital Projects Fund	Casper Ice Arena Chiller Repla	336,638.89
<i>HAASS CONSTRUCTION C - Total For Capital Projects Fund</i>			<i>\$336,638.89</i>
HAASS CONSTRUCTION C - ALL DEPARTMENTS			\$336,638.89

HACH CO., CORP.

HACH CO., CORP.	Water Tanks	SAMPLING CHEMICALS	\$804.82
<i>HACH CO., CORP. - Total For Water Tanks</i>			<i>\$804.82</i>
HACH CO., CORP. - ALL DEPARTMENTS			\$804.82

HARBOR FREIGHT TOOLS

HARBOR FREIGHT TOOLS	Aquatics - Pool	Locks for Lilly Pads at Mike Sedar	\$18.87
<i>HARBOR FREIGHT TOOLS - Total For Aquatics - Pool</i>			<i>\$18.87</i>
HARBOR FREIGHT TOOLS	Capital Projects Fund	Torque Wrench	\$109.99
<i>HARBOR FREIGHT TOOLS - Total For Capital Projects Fund</i>			<i>\$109.99</i>
HARBOR FREIGHT TOOLS	Fire-EMS Training	Tools and Supplies for training	\$82.44
<i>HARBOR FREIGHT TOOLS - Total For Fire-EMS Training</i>			<i>\$82.44</i>
HARBOR FREIGHT TOOLS	Parks - Athletic Maint.	HARDWARE STORES	\$11.98

<i>HARBOR FREIGHT TOOLS - Total For Parks - Athletic Maint.</i>			<i>\$11.98</i>
HARBOR FREIGHT TOOLS	Refuse - Residential	cleaning towels truck barn	\$34.68
<i>HARBOR FREIGHT TOOLS - Total For Refuse - Residential</i>			<i>\$34.68</i>
HARBOR FREIGHT TOOLS	Regional Water Operations	Tools	\$14.99
<i>HARBOR FREIGHT TOOLS - Total For Regional Water Operations</i>			<i>\$14.99</i>
HARBOR FREIGHT TOOLS - ALL DEPARTMENTS			\$272.95

HDR ENGINEERING, INC

HDR ENGINEERING, INC	Capital Projects Fund	Design of Paradise Valley to Robertson rd	\$41,640.30
<i>HDR ENGINEERING, INC - Total For Capital Projects Fund</i>			<i>\$41,640.30</i>
HDR ENGINEERING, INC	Water Tanks	Water Rights Studies	\$10,262.86
<i>HDR ENGINEERING, INC - Total For Water Tanks</i>			<i>\$10,262.86</i>
HDR ENGINEERING, INC - ALL DEPARTMENTS			\$51,903.16

HENSLEY BATTERY&ELEC

HENSLEY BATTERY&ELEC	Regional Water Operations	Batteries for LOX Tank	\$17.50
<i>HENSLEY BATTERY&ELEC - Total For Regional Water Operations</i>			<i>\$17.50</i>
HENSLEY BATTERY&ELEC - ALL DEPARTMENTS			\$17.50

HERSHBERGERS INC

HERSHBERGERS INC	Aquatics - Pool	Plaster	\$75.65
<i>HERSHBERGERS INC - Total For Aquatics - Pool</i>			<i>\$75.65</i>
HERSHBERGERS INC - ALL DEPARTMENTS			\$75.65

HIGH PLAINS CONSTRUC

HIGH PLAINS CONSTRUC	Water Tanks	CY Booster Station Replacement	341,567.39
<i>HIGH PLAINS CONSTRUC - Total For Water Tanks</i>			<i>\$341,567.39</i>
HIGH PLAINS CONSTRUC - ALL DEPARTMENTS			\$341,567.39

HITEK COMMUNICATIONS

HITEK COMMUNICATIONS	Balefill - Disposal & Landfill	repair gate camera	\$180.00
<i>HITEK COMMUNICATIONS - Total For Balefill - Disposal & Landfill</i>			<i>\$180.00</i>

HITEK COMMUNICATIONS - ALL DEPARTMENTS**\$180.00****HOLLY BRYSON**

HOLLY BRYSON	Parks - Parks Maint.	Traffic wrap art	\$200.00
--------------	----------------------	------------------	----------

<i>HOLLY BRYSON - Total For Parks - Parks Maint.</i>			<i>\$200.00</i>
--	--	--	-----------------

HOLLY BRYSON - ALL DEPARTMENTS**\$200.00****HOMAX OIL SALES INC**

HOMAX OIL SALES INC	Hogadon - Operations	Summer Fill Fuel Oil	\$1,746.92
---------------------	----------------------	----------------------	------------

<i>HOMAX OIL SALES INC - Total For Hogadon - Operations</i>			<i>\$1,746.92</i>
---	--	--	-------------------

HOMAX OIL SALES INC - ALL DEPARTMENTS**\$1,746.92****HOMAX OIL SALES, INC**

HOMAX OIL SALES, INC	Balefill - Disposal & Landfill	ldf diesel	\$9,057.75
----------------------	--------------------------------	------------	------------

<i>HOMAX OIL SALES, INC - Total For Balefill - Disposal & Landfill</i>			<i>\$9,057.75</i>
--	--	--	-------------------

HOMAX OIL SALES, INC	Fleet Maintenance Fund	stock 01/CGF	\$15,448.30
----------------------	------------------------	--------------	-------------

HOMAX OIL SALES, INC	Fleet Maintenance Fund	Stock 01/CGF	\$10,510.01
----------------------	------------------------	--------------	-------------

<i>HOMAX OIL SALES, INC - Total For Fleet Maintenance Fund</i>			<i>\$25,958.31</i>
--	--	--	--------------------

HOMAX OIL SALES, INC	Golf - Operations	Fuel	\$1,724.03
----------------------	-------------------	------	------------

<i>HOMAX OIL SALES, INC - Total For Golf - Operations</i>			<i>\$1,724.03</i>
---	--	--	-------------------

HOMAX OIL SALES, INC - ALL DEPARTMENTS**\$36,740.09****HOMEDEPOT.COM**

HOMEDEPOT.COM	Buildings & Structures Fund	Custodial Supplies for City Hall	\$195.12
---------------	-----------------------------	----------------------------------	----------

<i>HOMEDEPOT.COM - Total For Buildings & Structures Fund</i>			<i>\$195.12</i>
--	--	--	-----------------

HOMEDEPOT.COM - ALL DEPARTMENTS**\$195.12****HOMEWOOD SUITES**

HOMEWOOD SUITES	Police Administration	HOMEWOOD SUITES	\$131.10
-----------------	-----------------------	-----------------	----------

HOMEWOOD SUITES	Police Administration	HOMEWOOD SUITES	\$131.10
-----------------	-----------------------	-----------------	----------

HOMEWOOD SUITES	Police Administration	HOMEWOOD SUITES	\$131.10
-----------------	-----------------------	-----------------	----------

<i>HOMEWOOD SUITES - Total For Police Administration</i>			<i>\$393.30</i>
--	--	--	-----------------

HOMEWOOD SUITES - ALL DEPARTMENTS**\$393.30****HOSE & RUBBER**

HOSE & RUBBER	RWS - Booster Stations	Pioneer Booster Pump 1 and 2	\$57.46
---------------	------------------------	------------------------------	---------

<i>HOSE & RUBBER - Total For RWS - Booster Stations</i>			<i>\$57.46</i>
---	--	--	----------------

HOSE & RUBBER - ALL DEPARTMENTS**\$57.46****HOSE & RUBBER SUPPLY**

HOSE & RUBBER SUPPLY	Balefill - Diversion & Special	cam lock adapter	\$19.40
----------------------	--------------------------------	------------------	---------

<i>HOSE & RUBBER SUPPLY - Total For Balefill - Diversion & Special</i>			<i>\$19.40</i>
--	--	--	----------------

HOSE & RUBBER SUPPLY	Cemetery	COMMERCIAL EQUIPMENT new pump suction h	\$38.20
----------------------	----------	---	---------

<i>HOSE & RUBBER SUPPLY - Total For Cemetery</i>			<i>\$38.20</i>
--	--	--	----------------

HOSE & RUBBER SUPPLY	Meter Services	5/8 inch high grade hosing - Meter pit sump pu	\$42.83
----------------------	----------------	--	---------

<i>HOSE & RUBBER SUPPLY - Total For Meter Services</i>			<i>\$42.83</i>
--	--	--	----------------

HOSE & RUBBER SUPPLY	Regional Water Operations	truck load out gaskets	\$5.22
----------------------	---------------------------	------------------------	--------

<i>HOSE & RUBBER SUPPLY - Total For Regional Water Operations</i>			<i>\$5.22</i>
---	--	--	---------------

HOSE & RUBBER SUPPLY - ALL DEPARTMENTS**\$105.65****HP INC**

HP INC	Capital Projects Fund	Purchase of 11 A140's for PD Units	\$7,533.13
--------	-----------------------	------------------------------------	------------

<i>HP INC - Total For Capital Projects Fund</i>			<i>\$7,533.13</i>
---	--	--	-------------------

HP INC - ALL DEPARTMENTS**\$7,533.13****ID EDGE INC**

ID EDGE INC	Rec Center - Operations	OFFICE, PHOTOGRAPHIC, PHOTOCOPY, AND MI	\$582.75
-------------	-------------------------	---	----------

<i>ID EDGE INC - Total For Rec Center - Operations</i>			<i>\$582.75</i>
--	--	--	-----------------

ID EDGE INC - ALL DEPARTMENTS**\$582.75****IMLA**

IMLA	City Attorney	CIVIC, SOCIAL AND FRATERNAL ASSOCIATIONS	\$625.50
------	---------------	--	----------

IMLA	City Attorney	CIVIC, SOCIAL AND FRATERNAL ASSOCIATIONS	\$499.00
------	---------------	--	----------

<i>IMLA - Total For City Attorney</i>			<i>\$1,124.50</i>
---------------------------------------	--	--	-------------------

IMLA - ALL DEPARTMENTS**\$1,124.50****IMLSS COLORADO**

IMLSS COLORADO	Buildings & Structures Fund	Supplies to rekey Lift Stations	\$2,548.64
----------------	-----------------------------	---------------------------------	------------

<i>IMLSS COLORADO - Total For Buildings & Structures Fund</i>			<i>\$2,548.64</i>
---	--	--	-------------------

IMLSS COLORADO - ALL DEPARTMENTS**\$2,548.64****INBERG-MILLER ENGINE**

INBERG-MILLER ENGINE	Water Distribution	COMPACTION TESTING	\$579.00
----------------------	--------------------	--------------------	----------

<i>INBERG-MILLER ENGINE - Total For Water Distribution</i>			<i>\$579.00</i>
--	--	--	-----------------

INBERG-MILLER ENGINE - ALL DEPARTMENTS**\$579.00****INSTACART**

INSTACART	Balefill - Disposal & Landfill	GROCERY STORES, SUPERMARKETS	\$47.16
-----------	--------------------------------	------------------------------	---------

INSTACART	Balefill - Disposal & Landfill	GROCERY STORES, SUPERMARKETS	\$47.23
-----------	--------------------------------	------------------------------	---------

INSTACART	Balefill - Disposal & Landfill	GROCERY STORES, SUPERMARKETS	\$89.92
-----------	--------------------------------	------------------------------	---------

<i>INSTACART - Total For Balefill - Disposal & Landfill</i>			<i>\$184.31</i>
---	--	--	-----------------

INSTACART - ALL DEPARTMENTS**\$184.31****INTERMOUNTAIN MOTOR**

INTERMOUNTAIN MOTOR	RWS - Booster Stations	Motor repair for Pioneer Booster	\$1,197.84
---------------------	------------------------	----------------------------------	------------

INTERMOUNTAIN MOTOR	RWS - Booster Stations	Motor repair for Pioneer Booster	\$1,742.43
---------------------	------------------------	----------------------------------	------------

<i>INTERMOUNTAIN MOTOR - Total For RWS - Booster Stations</i>			<i>\$2,940.27</i>
---	--	--	-------------------

INTERMOUNTAIN MOTOR - ALL DEPARTMENTS**\$2,940.27****INT'L CODE COUNCIL I**

INT'L CODE COUNCIL I	Fire-EMS Administration	Fire Inspector I Web Series - Occupancies and O	\$59.00
----------------------	-------------------------	---	---------

<i>INT'L CODE COUNCIL I - Total For Fire-EMS Administration</i>			<i>\$59.00</i>
---	--	--	----------------

INT'L CODE COUNCIL I - ALL DEPARTMENTS**\$59.00****INTUIT, INC.**

INTUIT, INC.	Buildings & Structures Fund	Return of suit dryer parts	(\$99.60)
<i>INTUIT, INC. - Total For Buildings & Structures Fund</i>			<i>(\$99.60)</i>
INTUIT, INC.	Fire-EMS Operations	Wold Wash - Bill paid in error for cleaning at 19t	\$575.00
INTUIT, INC.	Fire-EMS Operations	World Wash - Credit for payment made in error	(\$575.00)
INTUIT, INC.	Fire-EMS Operations	Cost Plus - Repair of stove at fire Station 2	\$157.15
<i>INTUIT, INC. - Total For Fire-EMS Operations</i>			<i>\$157.15</i>
INTUIT, INC.	Refuse - Residential	BOLTS FOR TRUCK BARN	\$26.63
<i>INTUIT, INC. - Total For Refuse - Residential</i>			<i>\$26.63</i>
INTUIT, INC. - ALL DEPARTMENTS			\$84.18

ITRON

ITRON	Meter Services	IMA driveby	\$960.00
<i>ITRON - Total For Meter Services</i>			<i>\$960.00</i>
ITRON - ALL DEPARTMENTS			\$960.00

JACK'S TRUCK & EQUIP

JACK'S TRUCK & EQUIP	Fleet Maintenance Fund	111165 repairs	\$2,660.82
<i>JACK'S TRUCK & EQUIP - Total For Fleet Maintenance Fund</i>			<i>\$2,660.82</i>
JACK'S TRUCK & EQUIP - ALL DEPARTMENTS			\$2,660.82

JOHN E. REID AND ASS

JOHN E. REID AND ASS	Fire-EMS Prevent & Inspect	Interrogation Technique Class	\$575.00
<i>JOHN E. REID AND ASS - Total For Fire-EMS Prevent & Inspect</i>			<i>\$575.00</i>
JOHN E. REID AND ASS - ALL DEPARTMENTS			\$575.00

KINSCO

KINSCO	Fire-EMS Operations	CFD Work Shirts	\$174.00
KINSCO	Fire-EMS Operations	Gold Maltese Cross	\$48.00
<i>KINSCO - Total For Fire-EMS Operations</i>			<i>\$222.00</i>
KINSCO - ALL DEPARTMENTS			\$222.00

KNIFE RIVER 5701

KNIFE RIVER 5701	Water Distribution	BASE FOR CONWELL WATER LINE REPLACEMEN	\$375.85
<i>KNIFE RIVER 5701 - Total For Water Distribution</i>			<i>\$375.85</i>
KNIFE RIVER 5701 - ALL DEPARTMENTS			\$375.85

KNIFE RIVER/JTL

KNIFE RIVER/JTL	Water Distribution	Plant mix conwell st	\$7,330.04
<i>KNIFE RIVER/JTL - Total For Water Distribution</i>			<i>\$7,330.04</i>
KNIFE RIVER/JTL - ALL DEPARTMENTS			\$7,330.04

KUBWATER RESOURCES,

KUBWATER RESOURCES,	WWTP Operations	Zetag polymer for dewatering	\$5,618.85
<i>KUBWATER RESOURCES, - Total For WWTP Operations</i>			<i>\$5,618.85</i>
KUBWATER RESOURCES, - ALL DEPARTMENTS			\$5,618.85

LL JOHNSON DIST CO

LL JOHNSON DIST CO	Capital Projects Fund	2 - Maruyama Trimmers	\$1,109.43
<i>LL JOHNSON DIST CO - Total For Capital Projects Fund</i>			<i>\$1,109.43</i>
LL JOHNSON DIST CO	Hogadon - Operations	weed eater	\$75.51
<i>LL JOHNSON DIST CO - Total For Hogadon - Operations</i>			<i>\$75.51</i>
LL JOHNSON DIST CO - ALL DEPARTMENTS			\$1,184.94

LOAF N JUG #0106

LOAF N JUG #0106	Fire-EMS Operations	Propane	\$46.18
<i>LOAF N JUG #0106 - Total For Fire-EMS Operations</i>			<i>\$46.18</i>
LOAF N JUG #0106 - ALL DEPARTMENTS			\$46.18

LONG

LONG	Police Administration	labor blown fuse	\$110.00
<i>LONG - Total For Police Administration</i>			<i>\$110.00</i>
LONG - ALL DEPARTMENTS			\$110.00

MATTHEW J BUTCHER

MATTHEW J BUTCHER	General Fund Revenue	King blvd site review	\$1,440.00
MATTHEW J BUTCHER	General Fund Revenue	landmark dr site review	\$1,440.00
MATTHEW J BUTCHER	General Fund Revenue	Magnolia site reveiw	\$1,440.00
MATTHEW J BUTCHER	General Fund Revenue	center st wireless	\$1,440.00
<i>MATTHEW J BUTCHER - Total For General Fund Revenue</i>			\$5,760.00
MATTHEW J BUTCHER - ALL DEPARTMENTS			\$5,760.00

MCMURRY READY MIX CO

MCMURRY READY MIX CO	Streets	conwell and 8th concrete	\$292.75
<i>MCMURRY READY MIX CO - Total For Streets</i>			\$292.75
MCMURRY READY MIX CO - ALL DEPARTMENTS			\$292.75

MENARDS CASPER WY

MENARDS CASPER WY	Aquatics - Pool	Supplies for Lilly Pad ropes	\$21.45
<i>MENARDS CASPER WY - Total For Aquatics - Pool</i>			\$21.45
MENARDS CASPER WY	Balefill - Baler Processing	RETURN CREDIT	(\$33.45)
MENARDS CASPER WY	Balefill - Baler Processing	HOME SUPPLY WAREHOUSE STORES	\$31.86
MENARDS CASPER WY	Balefill - Baler Processing	HOME SUPPLY WAREHOUSE STORES	\$9.98
MENARDS CASPER WY	Balefill - Baler Processing	HOME SUPPLY WAREHOUSE STORES	\$33.45
<i>MENARDS CASPER WY - Total For Balefill - Baler Processing</i>			\$41.84
MENARDS CASPER WY	Cemetery	HOME SUPPLY WAREHOUSE STORESCEMETERY	\$71.96
<i>MENARDS CASPER WY - Total For Cemetery</i>			\$71.96
MENARDS CASPER WY	Ice Arena - Operations	ZEP FLOOR DEGREASER	\$34.99
<i>MENARDS CASPER WY - Total For Ice Arena - Operations</i>			\$34.99
MENARDS CASPER WY	Municipal Court	COVID19 Supplies	\$12.67
<i>MENARDS CASPER WY - Total For Municipal Court</i>			\$12.67
MENARDS CASPER WY	Sewer Wastewater Collection	shop tools	\$198.45
<i>MENARDS CASPER WY - Total For Sewer Wastewater Collection</i>			\$198.45
MENARDS CASPER WY	Water Distribution	SOAP, SPRAY BOTTLES, TOOLS (UNIT 273/266)	\$59.79
<i>MENARDS CASPER WY - Total For Water Distribution</i>			\$59.79
MENARDS CASPER WY	Water Tanks	Rock Creek Reservoir control valve	\$104.69
<i>MENARDS CASPER WY - Total For Water Tanks</i>			\$104.69

MENARDS CASPER WY	Weed & Pest Fund	Supplies	\$136.14
<i>MENARDS CASPER WY - Total For Weed & Pest Fund</i>			<i>\$136.14</i>
MENARDS CASPER WY - ALL DEPARTMENTS			\$681.98

MERBACK AWARDS COMPA

MERBACK AWARDS COMPA	Police Administration	award plaques	\$298.81
<i>MERBACK AWARDS COMPA - Total For Police Administration</i>			<i>\$298.81</i>
MERBACK AWARDS COMPA - ALL DEPARTMENTS			\$298.81

MICHELLE MARTIN

MICHELLE MARTIN	Parks - Parks Maint.	Traffic wrap art	\$200.00
<i>MICHELLE MARTIN - Total For Parks - Parks Maint.</i>			<i>\$200.00</i>
MICHELLE MARTIN - ALL DEPARTMENTS			\$200.00

MIDLAND IMPLEMENT, I

MIDLAND IMPLEMENT, I	Golf - Operations	Nozzle bases for Toro 750	\$46.94
MIDLAND IMPLEMENT, I	Golf - Operations	1 1/2 Inch sprinkler bodies, 750 caps, nozzle bas	\$512.89
<i>MIDLAND IMPLEMENT, I - Total For Golf - Operations</i>			<i>\$559.83</i>
MIDLAND IMPLEMENT, I - ALL DEPARTMENTS			\$559.83

MONTANA SEALS AND PA

MONTANA SEALS AND PA	WWTP Operations	Packing set	\$861.91
<i>MONTANA SEALS AND PA - Total For WWTP Operations</i>			<i>\$861.91</i>
MONTANA SEALS AND PA - ALL DEPARTMENTS			\$861.91

MOUNTAIN STATES

MOUNTAIN STATES	Meter Services	Door Hangers	\$199.21
MOUNTAIN STATES	Meter Services	Water dept door hangers	\$166.25
<i>MOUNTAIN STATES - Total For Meter Services</i>			<i>\$365.46</i>
MOUNTAIN STATES	Police State Grants	Victim service cards	\$79.36
<i>MOUNTAIN STATES - Total For Police State Grants</i>			<i>\$79.36</i>

MOUNTAIN STATES - ALL DEPARTMENTS**\$444.82****MOUNTAIN STATES LITH**

MOUNTAIN STATES LITH	Customer Service	Red Past-due billing notices	\$194.50
MOUNTAIN STATES LITH	Customer Service	GB Billing paper for invoices	\$277.03
MOUNTAIN STATES LITH	Customer Service	Preprinted envelopes	\$185.97

<i>MOUNTAIN STATES LITH - Total For Customer Service</i>			<i>\$657.50</i>
--	--	--	-----------------

MOUNTAIN STATES LITH - ALL DEPARTMENTS**\$657.50****MOUNTAIN WEST TELEPH**

MOUNTAIN WEST TELEPH	Aquatics - Pool	Internet installation at the outdoor pools	\$559.60
----------------------	-----------------	--	----------

<i>MOUNTAIN WEST TELEPH - Total For Aquatics - Pool</i>			<i>\$559.60</i>
---	--	--	-----------------

MOUNTAIN WEST TELEPH	Information Services	Enterprise Internet Service acct. 0000003191	\$1,000.00
----------------------	----------------------	--	------------

<i>MOUNTAIN WEST TELEPH - Total For Information Services</i>			<i>\$1,000.00</i>
--	--	--	-------------------

MOUNTAIN WEST TELEPH - ALL DEPARTMENTS**\$1,559.60****MUNICIPAL CODE CORP.**

MUNICIPAL CODE CORP.	Balefill - Baler Processing	Supplement 75	\$24.41
----------------------	-----------------------------	---------------	---------

<i>MUNICIPAL CODE CORP. - Total For Balefill - Baler Processing</i>			<i>\$24.41</i>
---	--	--	----------------

MUNICIPAL CODE CORP.	City Attorney	Supplement 75	\$170.94
----------------------	---------------	---------------	----------

<i>MUNICIPAL CODE CORP. - Total For City Attorney</i>			<i>\$170.94</i>
---	--	--	-----------------

MUNICIPAL CODE CORP.	City Council	Supplement 75	\$24.42
----------------------	--------------	---------------	---------

<i>MUNICIPAL CODE CORP. - Total For City Council</i>			<i>\$24.42</i>
--	--	--	----------------

MUNICIPAL CODE CORP.	Engineering	Supplement 75	\$24.42
----------------------	-------------	---------------	---------

<i>MUNICIPAL CODE CORP. - Total For Engineering</i>			<i>\$24.42</i>
---	--	--	----------------

MUNICIPAL CODE CORP.	Planning	Supplement 75	\$24.42
----------------------	----------	---------------	---------

<i>MUNICIPAL CODE CORP. - Total For Planning</i>			<i>\$24.42</i>
--	--	--	----------------

MUNICIPAL CODE CORP. - ALL DEPARTMENTS**\$268.61****MUNICIPAL EMERGENCY**

MUNICIPAL EMERGENCY	Fire-EMS Operations	Helmets	\$2,395.92
---------------------	---------------------	---------	------------

<i>MUNICIPAL EMERGENCY - Total For Fire-EMS Operations</i>			<i>\$2,395.92</i>
--	--	--	-------------------

MUNICIPAL EMERGENCY - ALL DEPARTMENTS**\$2,395.92****MURDOCH'S RANCH&HOME**

MURDOCH'S RANCH&HOM	Balefill - Baler Processing	SCREEN BALER SPRAY	\$95.93
---------------------	-----------------------------	--------------------	---------

<i>MURDOCH'S RANCH&HOME - Total For Balefill - Baler Processing</i>			\$95.93
---	--	--	---------

MURDOCH'S RANCH&HOM	Cemetery	1" trash pump for CEMETERY USE AND FITTINGS	\$474.29
---------------------	----------	---	----------

<i>MURDOCH'S RANCH&HOME - Total For Cemetery</i>			\$474.29
--	--	--	----------

MURDOCH'S RANCH&HOM	Metro Animal Shelter	ear tags	\$24.98
---------------------	----------------------	----------	---------

<i>MURDOCH'S RANCH&HOME - Total For Metro Animal Shelter</i>			\$24.98
--	--	--	---------

MURDOCH'S RANCH&HOME - ALL DEPARTMENTS**\$595.20****NAPA AUTO PARTS CORP**

NAPA AUTO PARTS CORP	Refuse - Residential	FLOOR DRY TRUCK BARN	\$41.96
----------------------	----------------------	----------------------	---------

NAPA AUTO PARTS CORP	Refuse - Residential	AUTOMOTIVE PARTS, ACCESSORIES STORES	\$92.48
----------------------	----------------------	--------------------------------------	---------

<i>NAPA AUTO PARTS CORP - Total For Refuse - Residential</i>			\$134.44
--	--	--	----------

NAPA AUTO PARTS CORP	Water Distribution	silicone for broken wand	\$11.99
----------------------	--------------------	--------------------------	---------

NAPA AUTO PARTS CORP	Water Distribution	Ignition coil for drill truck	\$32.28
----------------------	--------------------	-------------------------------	---------

NAPA AUTO PARTS CORP	Water Distribution	Silicone	\$47.96
----------------------	--------------------	----------	---------

NAPA AUTO PARTS CORP	Water Distribution	silicone & tape	\$46.96
----------------------	--------------------	-----------------	---------

<i>NAPA AUTO PARTS CORP - Total For Water Distribution</i>			\$139.19
--	--	--	----------

NAPA AUTO PARTS CORP - ALL DEPARTMENTS**\$273.63****NATIONAL PEN CO LLC**

NATIONAL PEN CO LLC	Hogadon - Operations	pens	\$210.00
---------------------	----------------------	------	----------

<i>NATIONAL PEN CO LLC - Total For Hogadon - Operations</i>			\$210.00
---	--	--	----------

NATIONAL PEN CO LLC - ALL DEPARTMENTS**\$210.00****NATRONA COUNTY OFFIC**

NATRONA COUNTY OFFIC	Municipal Court	May Rent	\$1,383.71
----------------------	-----------------	----------	------------

NATRONA COUNTY OFFIC	Municipal Court	April rent	\$2,262.21
----------------------	-----------------	------------	------------

NATRONA COUNTY OFFIC	Municipal Court	March Rent	\$1,825.81
----------------------	-----------------	------------	------------

NATRONA COUNTY OFFIC	Municipal Court	Feb rent	\$1,130.18
----------------------	-----------------	----------	------------

<i>NATRONA COUNTY OFFIC - Total For Municipal Court</i>			\$6,601.91
---	--	--	------------

NATRONA COUNTY OFFIC	Police Administration	March rent	\$11,215.72
NATRONA COUNTY OFFIC	Police Administration	May 2020 prisoner housing	\$90,059.04
NATRONA COUNTY OFFIC	Police Administration	April rent	\$13,896.43
NATRONA COUNTY OFFIC	Police Administration	Feb Rent	\$6,942.55
NATRONA COUNTY OFFIC	Police Administration	May rent	\$8,499.96
<i>NATRONA COUNTY OFFIC - Total For Police Administration</i>			<i>\$130,613.70</i>
NATRONA COUNTY OFFIC - ALL DEPARTMENTS			\$137,215.61

NATRONA COUNTY PUBLI

NATRONA COUNTY PUBLI	Capital Projects Fund	2020 Book Mobile	162,500.00
<i>NATRONA COUNTY PUBLI - Total For Capital Projects Fund</i>			<i>\$162,500.00</i>
NATRONA COUNTY PUBLI - ALL DEPARTMENTS			\$162,500.00

NELSON/NYGAARD CONSU

NELSON/NYGAARD CONSU	Metropolitan Planning Org	Mills Main Street Corridor Study	\$803.25
NELSON/NYGAARD CONSU	Metropolitan Planning Org	MPO 18-02 long range	\$22,103.92
<i>NELSON/NYGAARD CONSU - Total For Metropolitan Planning Org</i>			<i>\$22,907.17</i>
NELSON/NYGAARD CONSU - ALL DEPARTMENTS			\$22,907.17

NOLAND FEED

NOLAND FEED	Police Administration	canine food	\$122.54
<i>NOLAND FEED - Total For Police Administration</i>			<i>\$122.54</i>
NOLAND FEED - ALL DEPARTMENTS			\$122.54

NORCO, INC.

NORCO, INC.	Aquatics - Operations	Respirator Filters	\$493.61
<i>NORCO, INC. - Total For Aquatics - Operations</i>			<i>\$493.61</i>
NORCO, INC.	Fire-EMS Operations	Battalion Chief Shirts	\$296.22
<i>NORCO, INC. - Total For Fire-EMS Operations</i>			<i>\$296.22</i>
NORCO, INC.	Golf - Operations	Work gloves for seasonals and safety glasses	\$81.72
<i>NORCO, INC. - Total For Golf - Operations</i>			<i>\$81.72</i>
NORCO, INC.	Hogadon - Operations	supplies	\$215.36
<i>NORCO, INC. - Total For Hogadon - Operations</i>			<i>\$215.36</i>

NORCO, INC.	Parks - Special Areas	LAB/MEDICAL/DENTAL/OPHTHALMIC HOSPITAL	\$81.60
<i>NORCO, INC. - Total For Parks - Special Areas</i>			<i>\$81.60</i>
NORCO, INC.	Rec Center - Operations	LAB/MEDICAL/DENTAL/OPHTHALMIC HOSPITAL	\$416.60
<i>NORCO, INC. - Total For Rec Center - Operations</i>			<i>\$416.60</i>
NORCO, INC.	Refuse - Residential	dispensers	\$159.16
NORCO, INC.	Refuse - Residential	bags for depots	\$431.20
<i>NORCO, INC. - Total For Refuse - Residential</i>			<i>\$590.36</i>
NORCO, INC.	Regional Water Operations	PPE	\$113.13
<i>NORCO, INC. - Total For Regional Water Operations</i>			<i>\$113.13</i>
NORCO, INC.	Water Distribution	hard hat earmuff	\$57.77
<i>NORCO, INC. - Total For Water Distribution</i>			<i>\$57.77</i>
NORCO, INC.	WWTP Operations	Lime	\$865.00
<i>NORCO, INC. - Total For WWTP Operations</i>			<i>\$865.00</i>
NORCO, INC. - ALL DEPARTMENTS			\$3,211.37

NORTHERN LIGHTS MANU

NORTHERN LIGHTS MANU	Refuse - Commercial	222273 repairs	\$2,000.00
NORTHERN LIGHTS MANU	Refuse - Commercial	222283 fix doors on blade	\$1,500.00
<i>NORTHERN LIGHTS MANU - Total For Refuse - Commercial</i>			<i>\$3,500.00</i>
NORTHERN LIGHTS MANU - ALL DEPARTMENTS			\$3,500.00

NORTHWEST CONTRACTOR

NORTHWEST CONTRACTOR	Balefill - Baler Processing	Baler ops, steel plate	\$1,392.94
<i>NORTHWEST CONTRACTOR - Total For Balefill - Baler Processing</i>			<i>\$1,392.94</i>
NORTHWEST CONTRACTOR	Balefill - Disposal & Landfill	Epoxy grout	\$151.66
NORTHWEST CONTRACTOR	Balefill - Disposal & Landfill	Misc. supplies	\$185.16
<i>NORTHWEST CONTRACTOR - Total For Balefill - Disposal & Landfill</i>			<i>\$336.82</i>
NORTHWEST CONTRACTOR	Buildings & Structures Fund	Misc. tool	\$578.40
NORTHWEST CONTRACTOR	Buildings & Structures Fund	BAS Tools	\$23.74
NORTHWEST CONTRACTOR	Buildings & Structures Fund	anchor epoxy	\$37.84
NORTHWEST CONTRACTOR	Buildings & Structures Fund	Sure strike hammer	\$21.96
NORTHWEST CONTRACTOR	Buildings & Structures Fund	Gold concrete placer hook	\$60.00
<i>NORTHWEST CONTRACTOR - Total For Buildings & Structures Fund</i>			<i>\$721.94</i>
NORTHWEST CONTRACTOR	Regional Water Operations	Sand pump gaskets	\$37.56

<i>NORTHWEST CONTRACTOR - Total For Regional Water Operations</i>			\$37.56
NORTHWEST CONTRACTOR	Sewer Wastewater Collection	shop tools	\$795.85
NORTHWEST CONTRACTOR	Sewer Wastewater Collection	traffic cones for trucks	\$383.80
<i>NORTHWEST CONTRACTOR - Total For Sewer Wastewater Collection</i>			\$1,179.65
NORTHWEST CONTRACTOR	Water Tanks	Supplies for Water Department	\$3.00
<i>NORTHWEST CONTRACTOR - Total For Water Tanks</i>			\$3.00
NORTHWEST CONTRACTOR - ALL DEPARTMENTS			\$3,671.91

OLSON AUTOBODY & COL

OLSON AUTOBODY & COL	Fleet Maintenance Fund	claim no 2976 unit 101300 repairs	\$1,292.17
OLSON AUTOBODY & COL	Fleet Maintenance Fund	claim 2926, 660232 repairs	\$2,753.50
<i>OLSON AUTOBODY & COL - Total For Fleet Maintenance Fund</i>			\$4,045.67
OLSON AUTOBODY & COL - ALL DEPARTMENTS			\$4,045.67

O'REILLY AUTO PARTS

O'REILLY AUTO PARTS	Fire-EMS Operations	Spark Plugs and Rod Clips	\$9.95
<i>O'REILLY AUTO PARTS - Total For Fire-EMS Operations</i>			\$9.95
O'REILLY AUTO PARTS - ALL DEPARTMENTS			\$9.95

OVERHEAD DOOR CO

OVERHEAD DOOR CO	Buildings & Structures Fund	Cemetery repairs	\$687.32
<i>OVERHEAD DOOR CO - Total For Buildings & Structures Fund</i>			\$687.32
OVERHEAD DOOR CO - ALL DEPARTMENTS			\$687.32

PAPA JOHN'S #1393

PAPA JOHN'S #1393	Fire-EMS Operations	Food for Protest Operations	\$93.46
<i>PAPA JOHN'S #1393 - Total For Fire-EMS Operations</i>			\$93.46
PAPA JOHN'S #1393 - ALL DEPARTMENTS			\$93.46

PAYPAL CPSGI CPSGI

PAYPAL CPSGI CPSGI	Fire-EMS Training	Carterson Public Safety Group - Aggressive Com	\$20.00
PAYPAL CPSGI CPSGI	Fire-EMS Training	Carterson Public Safety Group - Aggressive Com	\$20.00

PAYPAL CPSGI CPSGI	Fire-EMS Training	Carterson Public Safety Group - Aggressive Com	\$20.00
PAYPAL CPSGI CPSGI	Fire-EMS Training	Carterson Public Safety Group - Aggressive Com	\$20.00
<i>PAYPAL CPSGI CPSGI - Total For Fire-EMS Training</i>			<i>\$80.00</i>
PAYPAL CPSGI CPSGI - ALL DEPARTMENTS			\$80.00

PCN STRATEGIES INC

PCN STRATEGIES INC	Capital Projects Fund	Purchase Getac Cameras PCN Strategies	\$97,533.09
<i>PCN STRATEGIES INC - Total For Capital Projects Fund</i>			<i>\$97,533.09</i>
PCN STRATEGIES INC	Police Administration	Purchase Getac Cameras PCN Strategies	\$21,821.86
<i>PCN STRATEGIES INC - Total For Police Administration</i>			<i>\$21,821.86</i>
PCN STRATEGIES INC - ALL DEPARTMENTS			\$119,354.95

PEDEN'S INC

PEDEN'S INC	Police Administration	Shirts, logo	\$333.00
<i>PEDEN'S INC - Total For Police Administration</i>			<i>\$333.00</i>
PEDEN'S INC - ALL DEPARTMENTS			\$333.00

PEPSI COLA OF CASPER

PEPSI COLA OF CASPER	Aquatics - Concessions	misc. drinks	\$674.50
<i>PEPSI COLA OF CASPER - Total For Aquatics - Concessions</i>			<i>\$674.50</i>
PEPSI COLA OF CASPER - ALL DEPARTMENTS			\$674.50

PHR WyomingCardio

PHR WyomingCardio	Fire-EMS Training	Medical Testing Services	\$1,211.00
<i>PHR WyomingCardio - Total For Fire-EMS Training</i>			<i>\$1,211.00</i>
PHR WyomingCardio - ALL DEPARTMENTS			\$1,211.00

PIONEER ATHLETICS

PIONEER ATHLETICS	Parks - Athletic Maint.	Field Paint	\$877.50
<i>PIONEER ATHLETICS - Total For Parks - Athletic Maint.</i>			<i>\$877.50</i>
PIONEER ATHLETICS - ALL DEPARTMENTS			\$877.50

PIPELOGIX INC

PIPELOGIX INC	Sewer Wastewater Collection Pipelogix software support program		\$2,500.00
<i>PIPELOGIX INC - Total For Sewer Wastewater Collection</i>			<i>\$2,500.00</i>
PIPELOGIX INC - ALL DEPARTMENTS			\$2,500.00

PIZZA HUT 035957

PIZZA HUT 035957	Fire-EMS Operations	Food for Protest Operations	\$130.84
<i>PIZZA HUT 035957 - Total For Fire-EMS Operations</i>			<i>\$130.84</i>
PIZZA HUT 035957 - ALL DEPARTMENTS			\$130.84

PLAYITAGAINSP

PLAYITAGAINSP	Ice Arena - Operations	PEE - Leather Batting Gloves for Stringing Goal N	\$39.98
<i>PLAYITAGAINSP - Total For Ice Arena - Operations</i>			<i>\$39.98</i>
PLAYITAGAINSP - ALL DEPARTMENTS			\$39.98

POLICE FACILITY DESI

POLICE FACILITY DESI	Capital Projects Fund	Architect for Public Safety Bu	\$2,975.00
<i>POLICE FACILITY DESI - Total For Capital Projects Fund</i>			<i>\$2,975.00</i>
POLICE FACILITY DESI - ALL DEPARTMENTS			\$2,975.00

POSTAL PROS, INC.

POSTAL PROS, INC.	Customer Service	Utility billing	\$2,531.71
POSTAL PROS, INC.	Customer Service	Utility billing	\$2,570.93
<i>POSTAL PROS, INC. - Total For Customer Service</i>			<i>\$5,102.64</i>
POSTAL PROS, INC. - ALL DEPARTMENTS			\$5,102.64

POTTERS FLEX O LITE

POTTERS FLEX O LITE	Traffic Control	6) 2000 LB sacks of reflective glass beads	\$3,648.00
POTTERS FLEX O LITE	Traffic Control	6000 LBS of reflective beads for striping	\$1,824.00
<i>POTTERS FLEX O LITE - Total For Traffic Control</i>			<i>\$5,472.00</i>

POTTERS FLEX O LITE - ALL DEPARTMENTS**\$5,472.00****PRINTWORKS**

PRINTWORKS	Water Distribution	Window envelopes	\$170.77
------------	--------------------	------------------	----------

<i>PRINTWORKS - Total For Water Distribution</i>			<i>\$170.77</i>
--	--	--	-----------------

PRINTWORKS - ALL DEPARTMENTS**\$170.77****PRO FLOORING, LLC**

PRO FLOORING, LLC	Golf - Operations	Golf clubhouse flooring	\$25,853.38
-------------------	-------------------	-------------------------	-------------

<i>PRO FLOORING, LLC - Total For Golf - Operations</i>			<i>\$25,853.38</i>
--	--	--	--------------------

PRO FLOORING, LLC - ALL DEPARTMENTS**\$25,853.38****PROFESSIONAL DEVELOP**

PROFESSIONAL DEVELOP	Information Services	Cyber-security Academy	\$1,695.00
----------------------	----------------------	------------------------	------------

<i>PROFESSIONAL DEVELOP - Total For Information Services</i>			<i>\$1,695.00</i>
--	--	--	-------------------

PROFESSIONAL DEVELOP - ALL DEPARTMENTS**\$1,695.00****PROFORCE LAW ENFORCE**

PROFORCE LAW ENFORCE	Police Administration	Sig romeo4s	\$2,248.19
----------------------	-----------------------	-------------	------------

<i>PROFORCE LAW ENFORCE - Total For Police Administration</i>			<i>\$2,248.19</i>
---	--	--	-------------------

PROFORCE LAW ENFORCE - ALL DEPARTMENTS**\$2,248.19****PROKOTEENGINEERINGSU**

PROKOTEENGINEERINGSU	Water Distribution	#10 BLUE TRACER WIRE	\$270.00
----------------------	--------------------	----------------------	----------

<i>PROKOTEENGINEERINGSU - Total For Water Distribution</i>			<i>\$270.00</i>
--	--	--	-----------------

PROKOTEENGINEERINGSU - ALL DEPARTMENTS**\$270.00****PSI SERVICES LLC**

PSI SERVICES LLC	Fire-EMS Administration	Unmanned General Recurrent Exam (Drone Lice	\$160.00
------------------	-------------------------	---	----------

<i>PSI SERVICES LLC - Total For Fire-EMS Administration</i>			<i>\$160.00</i>
---	--	--	-----------------

PSI SERVICES LLC - ALL DEPARTMENTS**\$160.00****QDOBA 2791**

QDOBA 2791	Fire-EMS Prevent & Inspect	Food for Protest Operations	\$28.35
------------	----------------------------	-----------------------------	---------

<i>QDOBA 2791 - Total For Fire-EMS Prevent & Inspect</i>			<i>\$28.35</i>
--	--	--	----------------

QDOBA 2791	Police Administration	meal/protest	\$135.00
------------	-----------------------	--------------	----------

<i>QDOBA 2791 - Total For Police Administration</i>			<i>\$135.00</i>
---	--	--	-----------------

QDOBA 2791 - ALL DEPARTMENTS**\$163.35****QDOBA 2895**

QDOBA 2895	Fire-EMS Operations	Food for Protest Operations	\$41.39
------------	---------------------	-----------------------------	---------

<i>QDOBA 2895 - Total For Fire-EMS Operations</i>			<i>\$41.39</i>
---	--	--	----------------

QDOBA 2895 - ALL DEPARTMENTS**\$41.39****RAMKOTA HOTEL AND CO**

RAMKOTA HOTEL AND CO	Police Administration	rooms for cheyenne pd to assist with protests	\$79.00
----------------------	-----------------------	---	---------

RAMKOTA HOTEL AND CO	Police Administration	rooms for cheyenne PD to assist with protests	\$79.00
----------------------	-----------------------	---	---------

RAMKOTA HOTEL AND CO	Police Administration	rooms for cheyenne pd to assist with protest	\$79.00
----------------------	-----------------------	--	---------

RAMKOTA HOTEL AND CO	Police Administration	Rooms for Cheyenne PD to assist with protest	\$79.00
----------------------	-----------------------	--	---------

RAMKOTA HOTEL AND CO	Police Administration	rooms for cheyenne pd to assist with protest	\$79.00
----------------------	-----------------------	--	---------

RAMKOTA HOTEL AND CO	Police Administration	rooms for cheyenne pd to assist with protest	\$79.00
----------------------	-----------------------	--	---------

<i>RAMKOTA HOTEL AND CO - Total For Police Administration</i>			<i>\$474.00</i>
---	--	--	-----------------

RAMKOTA HOTEL AND CO - ALL DEPARTMENTS**\$474.00****RIDLEY'S 1132**

RIDLEY'S 1132	Fire-EMS Training	Food for training	\$79.47
---------------	-------------------	-------------------	---------

<i>RIDLEY'S 1132 - Total For Fire-EMS Training</i>			<i>\$79.47</i>
--	--	--	----------------

RIDLEY'S 1132 - ALL DEPARTMENTS**\$79.47****RMI CASPER**

RMI CASPER	Streets	New reflective winter jackets	\$973.59
------------	---------	-------------------------------	----------

<i>RMI CASPER - Total For Streets</i>			<i>\$973.59</i>
---------------------------------------	--	--	-----------------

RMI CASPER	Traffic Control	New fall protection lanyard for bucket truck ope	\$356.00
RMI CASPER	Traffic Control	New fall protection harness for bucket truck op	\$369.00
<i>RMI CASPER - Total For Traffic Control</i>			<i>\$725.00</i>

RMI CASPER - ALL DEPARTMENTS **\$1,698.59**

ROCKY MOUNTAIN AIR S

ROCKY MOUNTAIN AIR S	Regional Water Operations	Chemical Oxygen	\$1,504.09
<i>ROCKY MOUNTAIN AIR S - Total For Regional Water Operations</i>			<i>\$1,504.09</i>
ROCKY MOUNTAIN AIR S	Water Distribution	Monthly cylinder rental charge	\$21.10
ROCKY MOUNTAIN AIR S	Water Distribution	MONTHLY CYLINDER RENTAL	\$21.47
<i>ROCKY MOUNTAIN AIR S - Total For Water Distribution</i>			<i>\$42.57</i>

ROCKY MOUNTAIN AIR S - ALL DEPARTMENTS **\$1,546.66**

ROCKY MOUNTAIN POWER

ROCKY MOUNTAIN POWER	Aquatics - Pool	Electricity acct. 54730761-112 9	\$497.15
<i>ROCKY MOUNTAIN POWER - Total For Aquatics - Pool</i>			<i>\$497.15</i>
ROCKY MOUNTAIN POWER	Balefill - Disposal & Landfill	Electricity 54730761-090 7	\$3,028.01
ROCKY MOUNTAIN POWER	Balefill - Disposal & Landfill	Ldf remediation acct. 54730761-139 2	\$293.31
<i>ROCKY MOUNTAIN POWER - Total For Balefill - Disposal & Landfill</i>			<i>\$3,321.32</i>
ROCKY MOUNTAIN POWER	Buildings & Structures Fund	Electricity acct. 54730761-089 9	\$130.40
<i>ROCKY MOUNTAIN POWER - Total For Buildings & Structures Fund</i>			<i>\$130.40</i>
ROCKY MOUNTAIN POWER	Fire-EMS Administration	Electricity acct. 54730761-141 8	\$556.54
<i>ROCKY MOUNTAIN POWER - Total For Fire-EMS Administration</i>			<i>\$556.54</i>
ROCKY MOUNTAIN POWER	Golf - Operations	Electricity acct. 54730761-099 8	\$1,452.17
<i>ROCKY MOUNTAIN POWER - Total For Golf - Operations</i>			<i>\$1,452.17</i>
ROCKY MOUNTAIN POWER	Parks - Athletic Maint.	Electricity acct 54730761-131 9	\$3,769.99
<i>ROCKY MOUNTAIN POWER - Total For Parks - Athletic Maint.</i>			<i>\$3,769.99</i>
ROCKY MOUNTAIN POWER	Parks - Parks Maint.	Electricity acct. 54730761-103 8	\$1,819.65
<i>ROCKY MOUNTAIN POWER - Total For Parks - Parks Maint.</i>			<i>\$1,819.65</i>
ROCKY MOUNTAIN POWER	Parks - Special Areas	Electricity acct. 54730761-115 2	\$59.22
<i>ROCKY MOUNTAIN POWER - Total For Parks - Special Areas</i>			<i>\$59.22</i>
ROCKY MOUNTAIN POWER	Regional Water Operations	Electricity multiple accounts	\$48,076.58
<i>ROCKY MOUNTAIN POWER - Total For Regional Water Operations</i>			<i>\$48,076.58</i>
ROCKY MOUNTAIN POWER	RWS - Booster Stations	Electricity multiple accounts	\$8,656.35

<i>ROCKY MOUNTAIN POWER - Total For RWS - Booster Stations</i>			<i>\$8,656.35</i>
ROCKY MOUNTAIN POWER	Traffic Control	Electricity acct. 54730761-118 6	\$66.49
<i>ROCKY MOUNTAIN POWER - Total For Traffic Control</i>			<i>\$66.49</i>
ROCKY MOUNTAIN POWER	Water Tanks	Electricity acct. 54730761-107 9	\$24,547.25
ROCKY MOUNTAIN POWER	Water Tanks	Electricity acct. 54730761-148 3	\$43.01
<i>ROCKY MOUNTAIN POWER - Total For Water Tanks</i>			<i>\$24,590.26</i>
ROCKY MOUNTAIN POWER - ALL DEPARTMENTS			\$92,996.12

ROCKY MTN. FIRE SYST

ROCKY MTN. FIRE SYST	Ice Arena - Operations	REPLACEMENT OF DEFECTIVE PULL STATION AT	\$137.60
<i>ROCKY MTN. FIRE SYST - Total For Ice Arena - Operations</i>			<i>\$137.60</i>
ROCKY MTN. FIRE SYST - ALL DEPARTMENTS			\$137.60

Rooter

Rooter	Parks - Parks Maint.	Portable toilets	\$216.44
Rooter	Parks - Parks Maint.	Provide/Install/Service Rented portable toilets	\$64.56
Rooter	Parks - Parks Maint.	Portable toilets	\$373.68
<i>Rooter - Total For Parks - Parks Maint.</i>			<i>\$654.68</i>
Rooter - ALL DEPARTMENTS			\$654.68

RUFF KUTT KUSTOMZ

RUFF KUTT KUSTOMZ	Refuse - Commercial	rotating garbage cans	\$10,000.00
<i>RUFF KUTT KUSTOMZ - Total For Refuse - Commercial</i>			<i>\$10,000.00</i>
RUFF KUTT KUSTOMZ - ALL DEPARTMENTS			\$10,000.00

RUSTY HALSEY

RUSTY HALSEY	Parks - Parks Maint.	Traffic wrap art	\$200.00
<i>RUSTY HALSEY - Total For Parks - Parks Maint.</i>			<i>\$200.00</i>
RUSTY HALSEY - ALL DEPARTMENTS			\$200.00

S&S WORLDWIDE,

S&S WORLDWIDE,	Rec Center - Classes	HOBBY,TOY, AND GAME SHOPS	\$30.04
----------------	----------------------	---------------------------	---------

<i>S&S WORLDWIDE, - Total For Rec Center - Classes</i>			<i>\$30.04</i>
S&S WORLDWIDE, - ALL DEPARTMENTS			\$30.04

S/D, INC.

S/D, INC.	Golf - Operations	Urinal screen	\$110.00
<i>S/D, INC. - Total For Golf - Operations</i>			<i>\$110.00</i>
S/D, INC. - ALL DEPARTMENTS			\$110.00

SALTUS TECHNOLOGIES,

SALTUS TECHNOLOGIES,	Police Administration	Digiticket Paper	\$1,000.00
<i>SALTUS TECHNOLOGIES, - Total For Police Administration</i>			<i>\$1,000.00</i>
SALTUS TECHNOLOGIES, - ALL DEPARTMENTS			\$1,000.00

SAMS CLUB #6425

SAMS CLUB #6425	Aquatics - Concessions	Concision items for outdoor pools	\$488.74
<i>SAMS CLUB #6425 - Total For Aquatics - Concessions</i>			<i>\$488.74</i>
SAMS CLUB #6425	Buildings & Structures Fund	Custodial Supplies for City Hall	\$49.92
<i>SAMS CLUB #6425 - Total For Buildings & Structures Fund</i>			<i>\$49.92</i>
SAMS CLUB #6425	Human Resources	Chili Skate Night Supplies	\$152.80
<i>SAMS CLUB #6425 - Total For Human Resources</i>			<i>\$152.80</i>
SAMS CLUB #6425	Information Services	IT Coffee	\$59.58
<i>SAMS CLUB #6425 - Total For Information Services</i>			<i>\$59.58</i>
SAMS CLUB #6425	Parks - Parks Maint.	WHOLESALE CLUBS	\$34.96
<i>SAMS CLUB #6425 - Total For Parks - Parks Maint.</i>			<i>\$34.96</i>
SAMS CLUB #6425	Police Administration	gatorade for protest	\$38.94
<i>SAMS CLUB #6425 - Total For Police Administration</i>			<i>\$38.94</i>
SAMS CLUB #6425	Rec Center - Classes	WHOLESALE CLUBS	\$38.06
<i>SAMS CLUB #6425 - Total For Rec Center - Classes</i>			<i>\$38.06</i>
SAMS CLUB #6425	Rec Center - Operations	WHOLESALE CLUBS	\$23.96
<i>SAMS CLUB #6425 - Total For Rec Center - Operations</i>			<i>\$23.96</i>
SAMS CLUB #6425 - ALL DEPARTMENTS			\$886.96

SAMSCLUB #6425

SAMSCLUB #6425	Aquatics - Concessions	Concession Supplies	\$206.34
SAMSCLUB #6425	Aquatics - Concessions	Supplies for Concessions	\$296.82
<i>SAMSCLUB #6425 - Total For Aquatics - Concessions</i>			<i>\$503.16</i>
SAMSCLUB #6425	Aquatics - Pool	Supplies for outdoor pools	\$54.10
<i>SAMSCLUB #6425 - Total For Aquatics - Pool</i>			<i>\$54.10</i>
SAMSCLUB #6425	City Council	MANAGER	\$62.88
SAMSCLUB #6425	City Council	MANAGER	\$102.44
<i>SAMSCLUB #6425 - Total For City Council</i>			<i>\$165.32</i>
SAMSCLUB #6425	Fire-EMS Operations	Station Supplies	\$502.88
<i>SAMSCLUB #6425 - Total For Fire-EMS Operations</i>			<i>\$502.88</i>
SAMSCLUB #6425	Water Distribution	OFFICE/CLEANING SUPPLIES	\$189.48
<i>SAMSCLUB #6425 - Total For Water Distribution</i>			<i>\$189.48</i>
SAMSCLUB #6425	WWTP Operations	Cleaner, detergent, kitchen supplies	\$194.81
<i>SAMSCLUB #6425 - Total For WWTP Operations</i>			<i>\$194.81</i>
SAMSCLUB #6425 - ALL DEPARTMENTS			\$1,609.75

SAMSCLUB.COM

SAMSCLUB.COM	Buildings & Structures Fund	Trash Cans for City Hall	\$892.20
<i>SAMSCLUB.COM - Total For Buildings & Structures Fund</i>			<i>\$892.20</i>
SAMSCLUB.COM	Fire-EMS Operations	Station Supplies	\$219.64
SAMSCLUB.COM	Fire-EMS Operations	Station Supplies	\$209.40
SAMSCLUB.COM	Fire-EMS Operations	Station Supplies	\$327.23
<i>SAMSCLUB.COM - Total For Fire-EMS Operations</i>			<i>\$756.27</i>
SAMSCLUB.COM - ALL DEPARTMENTS			\$1,648.47

SERPENTIX CONVEYOR C

SERPENTIX CONVEYOR C	WWTP Operations	Scrapers for dewatering	\$112.50
<i>SERPENTIX CONVEYOR C - Total For WWTP Operations</i>			<i>\$112.50</i>
SERPENTIX CONVEYOR C - ALL DEPARTMENTS			\$112.50

SHEET METAL SPECIALT

SHEET METAL SPECIALT	Capital Projects Fund	Hogadon AC Construction	\$79,200.00
<i>SHEET METAL SPECIALT - Total For Capital Projects Fund</i>			<i>\$79,200.00</i>

SHEET METAL SPECIALT - ALL DEPARTMENTS**\$79,200.00****SHELL OIL 5744427920**

SHELL OIL 5744427920	Fire-EMS Operations	Fuel	\$17.95
SHELL OIL 5744427920	Fire-EMS Operations	Fuel	\$52.59
SHELL OIL 5744427920	Fire-EMS Operations	Fuel	\$22.42
SHELL OIL 5744427920	Fire-EMS Operations	Fuel	\$45.39
SHELL OIL 5744427920	Fire-EMS Operations	Good 2 Go - Fuel	\$23.31

<i>SHELL OIL 5744427920 - Total For Fire-EMS Operations</i>			<i>\$161.66</i>
---	--	--	-----------------

SHELL OIL 5744427920 - ALL DEPARTMENTS**\$161.66****SHERWIN-WILLIAMS COR**

SHERWIN-WILLIAMS COR	Golf - Operations	paint sample	\$26.31
----------------------	-------------------	--------------	---------

<i>SHERWIN-WILLIAMS COR - Total For Golf - Operations</i>			<i>\$26.31</i>
---	--	--	----------------

SHERWIN-WILLIAMS COR	Ice Arena - Operations	WHITE PAINT FOR LOBBY, LOCKER ROOM, AREN	\$446.85
----------------------	------------------------	--	----------

SHERWIN-WILLIAMS COR	Ice Arena - Operations	WHITE PAINT FOR ARENA, LOBBY	\$169.19
----------------------	------------------------	------------------------------	----------

<i>SHERWIN-WILLIAMS COR - Total For Ice Arena - Operations</i>			<i>\$616.04</i>
--	--	--	-----------------

SHERWIN-WILLIAMS COR	Refuse - Residential	Paint	\$49.96
----------------------	----------------------	-------	---------

<i>SHERWIN-WILLIAMS COR - Total For Refuse - Residential</i>			<i>\$49.96</i>
--	--	--	----------------

SHERWIN-WILLIAMS COR - ALL DEPARTMENTS**\$692.31****SHIRTS & MORE INC**

SHIRTS & MORE INC	Parks - Parks Maint.	Traffic Box Wraps	\$1,400.00
-------------------	----------------------	-------------------	------------

<i>SHIRTS & MORE INC - Total For Parks - Parks Maint.</i>			<i>\$1,400.00</i>
---	--	--	-------------------

SHIRTS & MORE INC - ALL DEPARTMENTS**\$1,400.00****SHIRTSPACE.COM**

SHIRTSPACE.COM	Police Administration	incorrect invoice/credit next	\$261.61
----------------	-----------------------	-------------------------------	----------

SHIRTSPACE.COM	Police Administration	charge and credit for incorrect charge	(\$261.61)
----------------	-----------------------	--	------------

<i>SHIRTSPACE.COM - Total For Police Administration</i>			<i>\$0.00</i>
---	--	--	---------------

SHIRTSPACE.COM	Police State Grants	clothing & tote bags for sane program	\$249.15
----------------	---------------------	---------------------------------------	----------

<i>SHIRTSPACE.COM - Total For Police State Grants</i>			<i>\$249.15</i>
---	--	--	-----------------

SHIRTSPACE.COM - ALL DEPARTMENTS**\$249.15****SHOPLET.COM**

SHOPLET.COM	City Council	Return of Thermometers	(\$2,171.39)
-------------	--------------	------------------------	--------------

<i>SHOPLET.COM - Total For City Council</i>			<i>(\$2,171.39)</i>
---	--	--	---------------------

SHOPLET.COM - ALL DEPARTMENTS**(\$2,171.39)****SIMPLOT T&H DEN**

SIMPLOT T&H DEN	Weed & Pest Fund	Broadleaf herbicide	\$1,412.00
-----------------	------------------	---------------------	------------

<i>SIMPLOT T&H DEN - Total For Weed & Pest Fund</i>			<i>\$1,412.00</i>
---	--	--	-------------------

SIMPLOT T&H DEN - ALL DEPARTMENTS**\$1,412.00****SKYLINE RANCHES**

SKYLINE RANCHES	Sewer Fund	June sewer	\$990.80
-----------------	------------	------------	----------

SKYLINE RANCHES	Sewer Fund	June sewer	(\$99.08)
-----------------	------------	------------	-----------

SKYLINE RANCHES	Sewer Fund	May sewer	\$985.49
-----------------	------------	-----------	----------

SKYLINE RANCHES	Sewer Fund	May sewer	(\$98.54)
-----------------	------------	-----------	-----------

<i>SKYLINE RANCHES - Total For Sewer Fund</i>			<i>\$1,778.67</i>
---	--	--	-------------------

SKYLINE RANCHES	WWTP Revenue and Transfer	June sewer	(\$650.32)
-----------------	---------------------------	------------	------------

SKYLINE RANCHES	WWTP Revenue and Transfer	May sewer	(\$650.32)
-----------------	---------------------------	-----------	------------

<i>SKYLINE RANCHES - Total For WWTP Revenue and Transfers</i>			<i>(\$1,300.64)</i>
---	--	--	---------------------

SKYLINE RANCHES - ALL DEPARTMENTS**\$478.03****SLUMBERLAND U6**

SLUMBERLAND U6	Golf - Operations	Decor 19th Hole	\$149.99
----------------	-------------------	-----------------	----------

<i>SLUMBERLAND U6 - Total For Golf - Operations</i>			<i>\$149.99</i>
---	--	--	-----------------

SLUMBERLAND U6 - ALL DEPARTMENTS**\$149.99****SMITHS FOOD #4185**

SMITHS FOOD #4185	Fire-EMS Operations	Water Softener Salt	\$17.97
-------------------	---------------------	---------------------	---------

<i>SMITHS FOOD #4185 - Total For Fire-EMS Operations</i>			<i>\$17.97</i>
--	--	--	----------------

SMITHS FOOD #4185 - ALL DEPARTMENTS**\$17.97****SPECTRUM REACH**

SPECTRUM REACH	Public Safety Communication	CABLE, SATELLITE & OTHER PAY TV/RADIO SE	\$84.63
----------------	-----------------------------	--	---------

<i>SPECTRUM REACH - Total For Public Safety Communications</i>			<i>\$84.63</i>
--	--	--	----------------

SPECTRUM REACH - ALL DEPARTMENTS**\$84.63****SPORTSMANS WAREHOUSE**

SPORTSMANS WAREHOUSE	Balefill - Diversion & Special	SPORTING GOODS STORES	\$89.90
----------------------	--------------------------------	-----------------------	---------

<i>SPORTSMANS WAREHOUSE - Total For Balefill - Diversion & Special</i>			<i>\$89.90</i>
--	--	--	----------------

SPORTSMANS WAREHOUSE - ALL DEPARTMENTS**\$89.90****SQ 307 POWERWASH SE**

SQ 307 POWERWASH SE	Capital Projects Fund	Graffiti removal	\$900.00
---------------------	-----------------------	------------------	----------

<i>SQ 307 POWERWASH SE - Total For Capital Projects Fund</i>			<i>\$900.00</i>
--	--	--	-----------------

SQ 307 POWERWASH SE	Golf - Operations	Accidental charge credited back	\$9,000.04
---------------------	-------------------	---------------------------------	------------

SQ 307 POWERWASH SE	Golf - Operations	MISCELLANEOUS AND RETAIL STORES	(\$9,000.04)
---------------------	-------------------	---------------------------------	--------------

<i>SQ 307 POWERWASH SE - Total For Golf - Operations</i>			<i>\$0.00</i>
--	--	--	---------------

SQ 307 POWERWASH SE - ALL DEPARTMENTS**\$900.00****SQ FIRE BY TRADE**

SQ FIRE BY TRADE	Fire-EMS Operations	Pro Bar & Lock Slot 8	\$375.00
------------------	---------------------	-----------------------	----------

<i>SQ FIRE BY TRADE - Total For Fire-EMS Operations</i>			<i>\$375.00</i>
---	--	--	-----------------

SQ FIRE BY TRADE - ALL DEPARTMENTS**\$375.00****SQ J.R. S HUNT; FOR**

SQ J.R. S HUNT; FOR	Balefill - Disposal & Landfill	PHOTOGRAPHS FOR CONFERENCE ROOM	\$320.00
---------------------	--------------------------------	---------------------------------	----------

<i>SQ J.R. S HUNT; FOR - Total For Balefill - Disposal & Landfill</i>			<i>\$320.00</i>
---	--	--	-----------------

SQ J.R. S HUNT; FOR - ALL DEPARTMENTS**\$320.00****SQ MY EDUCATIONAL R**

SQ MY EDUCATIONAL R	Police Grants Fund	cpr training supplies certs	\$416.00
<i>SQ MY EDUCATIONAL R - Total For Police Grants Fund</i>			<i>\$416.00</i>
SQ MY EDUCATIONAL R - ALL DEPARTMENTS			\$416.00

SQ PEAK RESCUE

SQ PEAK RESCUE	Fire-EMS Operations	Running Shoes	\$778.00
<i>SQ PEAK RESCUE - Total For Fire-EMS Operations</i>			<i>\$778.00</i>
SQ PEAK RESCUE - ALL DEPARTMENTS			\$778.00

SQ PEDEN'S INC.

SQ PEDEN'S INC.	Aquatics - Pool	Guard Shirts	\$752.00
<i>SQ PEDEN'S INC. - Total For Aquatics - Pool</i>			<i>\$752.00</i>
SQ PEDEN'S INC.	Buildings & Structures Fund	BAS Replacement Shirts	\$270.00
<i>SQ PEDEN'S INC. - Total For Buildings & Structures Fund</i>			<i>\$270.00</i>
SQ PEDEN'S INC.	Hogadon - Operations	Uniform embroidery	\$10.00
<i>SQ PEDEN'S INC. - Total For Hogadon - Operations</i>			<i>\$10.00</i>
SQ PEDEN'S INC.	Police Administration	cso uniforms	\$262.00
<i>SQ PEDEN'S INC. - Total For Police Administration</i>			<i>\$262.00</i>
SQ PEDEN'S INC. - ALL DEPARTMENTS			\$1,294.00

SQ STEAMBOAT DELI

SQ STEAMBOAT DELI	City Council	MRF TOUR LUNCH	\$60.72
<i>SQ STEAMBOAT DELI - Total For City Council</i>			<i>\$60.72</i>
SQ STEAMBOAT DELI - ALL DEPARTMENTS			\$60.72

SQ SUMMIT ELECTRIC

SQ SUMMIT ELECTRIC	Ft. Caspar Museum	Ballast repair in hall light fixture	\$288.50
<i>SQ SUMMIT ELECTRIC - Total For Ft. Caspar Museum</i>			<i>\$288.50</i>
SQ SUMMIT ELECTRIC	Hogadon - Operations	ELECTRICAL outlet for waterline and rook drains	\$536.25
<i>SQ SUMMIT ELECTRIC - Total For Hogadon - Operations</i>			<i>\$536.25</i>
SQ SUMMIT ELECTRIC - ALL DEPARTMENTS			\$824.75

STALKER RADAR

STALKER RADAR	Capital Projects Fund	ELECTRONIC SALES	\$210.00
<i>STALKER RADAR - Total For Capital Projects Fund</i>			<i>\$210.00</i>
STALKER RADAR - ALL DEPARTMENTS			\$210.00

STAPLES

STAPLES	Cemetery	STATIONARY, OFFICE SUPPLIES	\$35.14
<i>STAPLES - Total For Cemetery</i>			<i>\$35.14</i>
STAPLES	Fire-EMS Prevent & Inspect	Printer, Car Port, Cord	\$254.97
STAPLES	Fire-EMS Prevent & Inspect	Glass and iPad Pro 12	\$64.99
STAPLES	Fire-EMS Prevent & Inspect	White Board Supplies	\$7.99
<i>STAPLES - Total For Fire-EMS Prevent & Inspect</i>			<i>\$327.95</i>
STAPLES	Municipal Court	Office Supplies	\$901.80
STAPLES	Municipal Court	Office Supplies	\$34.38
<i>STAPLES - Total For Municipal Court</i>			<i>\$936.18</i>
STAPLES	Refuse - Residential	FOLDER HOLDER TRUCK BARN	\$23.97
<i>STAPLES - Total For Refuse - Residential</i>			<i>\$23.97</i>
STAPLES	Sewer Wastewater Collection	office supplies	\$38.98
<i>STAPLES - Total For Sewer Wastewater Collection</i>			<i>\$38.98</i>
STAPLES - ALL DEPARTMENTS			\$1,362.22

STAPLES DIRECT

STAPLES DIRECT	Fire-EMS Administration	Refund of sales tax	(\$8.05)
<i>STAPLES DIRECT - Total For Fire-EMS Administration</i>			<i>(\$8.05)</i>
STAPLES DIRECT	Fire-EMS Prevent & Inspect	Dry Erase Board	\$172.03
<i>STAPLES DIRECT - Total For Fire-EMS Prevent & Inspect</i>			<i>\$172.03</i>
STAPLES DIRECT	Municipal Court	COVID Signs for A Frame Stands	\$88.18
STAPLES DIRECT	Municipal Court	Office Supplies	\$302.33
<i>STAPLES DIRECT - Total For Municipal Court</i>			<i>\$390.51</i>
STAPLES DIRECT	Refuse - Residential	TONER CARTRIDGE	\$84.99
<i>STAPLES DIRECT - Total For Refuse - Residential</i>			<i>\$84.99</i>
STAPLES DIRECT - ALL DEPARTMENTS			\$639.48

STATE OF WY.

STATE OF WY.	Aquatics - Pool	Marion Kraner splash pad 9346	\$50.00
<i>STATE OF WY. - Total For Aquatics - Pool</i>			<i>\$50.00</i>
STATE OF WY.	Municipal Court	Drury, Aja and White, Adrian application fee	\$60.00
<i>STATE OF WY. - Total For Municipal Court</i>			<i>\$60.00</i>
STATE OF WY.	Police State Grants	Refund	\$300.00
<i>STATE OF WY. - Total For Police State Grants</i>			<i>\$300.00</i>
STATE OF WY. - ALL DEPARTMENTS			\$410.00

STOTZ EQUIPMENT

STOTZ EQUIPMENT	Weed & Pest Fund	Lease for Pull mower and tract	\$3,850.00
<i>STOTZ EQUIPMENT - Total For Weed & Pest Fund</i>			<i>\$3,850.00</i>
STOTZ EQUIPMENT - ALL DEPARTMENTS			\$3,850.00

SUBWAY

SUBWAY	Regional Water Operations	Lunch for training SCADA	\$62.91
<i>SUBWAY - Total For Regional Water Operations</i>			<i>\$62.91</i>
SUBWAY - ALL DEPARTMENTS			\$62.91

SUMMIT ELECTRIC LLC.

SUMMIT ELECTRIC LLC.	Buildings & Structures Fund	Golf course a/c	\$1,219.05
<i>SUMMIT ELECTRIC LLC. - Total For Buildings & Structures Fund</i>			<i>\$1,219.05</i>
SUMMIT ELECTRIC LLC. - ALL DEPARTMENTS			\$1,219.05

SUTHERLANDS 2219

SUTHERLANDS 2219	Aquatics - Pool	Jug for Disinfectant	\$47.97
SUTHERLANDS 2219	Aquatics - Pool	Supplies for plaster repair	\$10.98
<i>SUTHERLANDS 2219 - Total For Aquatics - Pool</i>			<i>\$58.95</i>
SUTHERLANDS 2219	Fire-EMS Operations	Grass Trimmer Line	\$8.99
<i>SUTHERLANDS 2219 - Total For Fire-EMS Operations</i>			<i>\$8.99</i>
SUTHERLANDS 2219	Golf - Operations	Cleanout body with plug for 19th hole	\$8.99
SUTHERLANDS 2219	Golf - Operations	Wall plates for 19th Hole	\$2.10

SUTHERLANDS 2219	Golf - Operations	Fasteners	\$2.29
<i>SUTHERLANDS 2219 - Total For Golf - Operations</i>			<i>\$13.38</i>
SUTHERLANDS 2219	Refuse - Residential	LUMBER AND BUILDING MATERIALS STORES	\$47.61
<i>SUTHERLANDS 2219 - Total For Refuse - Residential</i>			<i>\$47.61</i>
SUTHERLANDS 2219	Water Distribution	Supplies for Chaparrel repairs	\$23.37
<i>SUTHERLANDS 2219 - Total For Water Distribution</i>			<i>\$23.37</i>
SUTHERLANDS 2219 - ALL DEPARTMENTS			\$152.30

TARGET

TARGET	Fire-EMS Operations	Sissors	\$8.91
<i>TARGET - Total For Fire-EMS Operations</i>			<i>\$8.91</i>
TARGET	Fire-EMS Prevent & Inspect	Multimedia Speaker System	\$135.99
<i>TARGET - Total For Fire-EMS Prevent & Inspect</i>			<i>\$135.99</i>
TARGET - ALL DEPARTMENTS			\$144.90

TEST GAUGE & BACKFLO

TEST GAUGE & BACKFLO	Water Distribution	BACKFLOW GAUGE TEST/RECERT.	\$197.23
<i>TEST GAUGE & BACKFLO - Total For Water Distribution</i>			<i>\$197.23</i>
TEST GAUGE & BACKFLO - ALL DEPARTMENTS			\$197.23

THATCHER CO.

THATCHER CO.	WWTP Regional Interceptors	Ferrous chloride delivery on 6/23/2020	\$8,842.68
<i>THATCHER CO. - Total For WWTP Regional Interceptors</i>			<i>\$8,842.68</i>
THATCHER CO. - ALL DEPARTMENTS			\$8,842.68

THE HOME DEPOT

THE HOME DEPOT	Buildings & Structures Fund	Custodial Supplies for City Hall	\$32.33
THE HOME DEPOT	Buildings & Structures Fund	Bug spray for the BAS building	\$15.47
<i>THE HOME DEPOT - Total For Buildings & Structures Fund</i>			<i>\$47.80</i>
THE HOME DEPOT	Capital Projects Fund	Steel Cabinet	\$299.00
THE HOME DEPOT	Capital Projects Fund	Ground Clear	\$75.94
<i>THE HOME DEPOT - Total For Capital Projects Fund</i>			<i>\$374.94</i>
THE HOME DEPOT	Cemetery	HOME SUPPLY WAREHOUSE STORES CEMETERY	\$75.48

THE HOME DEPOT	Cemetery	HOME SUPPLY WAREHOUSE STORES CLIPPERS F	\$31.96
<i>THE HOME DEPOT - Total For Cemetery</i>			\$107.44
THE HOME DEPOT	City Council	Coupler Lock	\$29.64
<i>THE HOME DEPOT - Total For City Council</i>			\$29.64
THE HOME DEPOT	Fire-EMS Operations	Trash can and grass trimmer line	\$64.88
<i>THE HOME DEPOT - Total For Fire-EMS Operations</i>			\$64.88
THE HOME DEPOT	Fire-EMS Prevent & Inspect	Hillman 3G Powdered Graphite Lube	\$20.92
<i>THE HOME DEPOT - Total For Fire-EMS Prevent & Inspect</i>			\$20.92
THE HOME DEPOT	Fire-EMS Training	Drill Tower Supplies	\$46.31
<i>THE HOME DEPOT - Total For Fire-EMS Training</i>			\$46.31
THE HOME DEPOT	Golf - Operations	Drywall anchors	\$55.40
THE HOME DEPOT	Golf - Operations	String trimmer string, paper towel rolls	\$76.91
<i>THE HOME DEPOT - Total For Golf - Operations</i>			\$132.31
THE HOME DEPOT	Meter Services	Return defective hose	(\$16.98)
<i>THE HOME DEPOT - Total For Meter Services</i>			(\$16.98)
THE HOME DEPOT	Parks - Athletic Maint.	Multi Use Sprayers for clay	\$39.94
<i>THE HOME DEPOT - Total For Parks - Athletic Maint.</i>			\$39.94
THE HOME DEPOT	Parks - Parks Maint.	Tools	\$56.61
THE HOME DEPOT	Parks - Parks Maint.	Wall anchors	\$45.08
<i>THE HOME DEPOT - Total For Parks - Parks Maint.</i>			\$101.69
THE HOME DEPOT	Water Tanks	MTN. RD. ROOF VENT UPGRADE	\$7.10
<i>THE HOME DEPOT - Total For Water Tanks</i>			\$7.10
THE HOME DEPOT - ALL DEPARTMENTS			\$955.99

THE UPS STORE

THE UPS STORE	Buildings & Structures Fund	Shipping to send Parking Garage gate control to	\$20.53
<i>THE UPS STORE - Total For Buildings & Structures Fund</i>			\$20.53

THE UPS STORE - ALL DEPARTMENTS **\$20.53**

THOMSON WEST TCD

THOMSON WEST TCD	City Attorney	PROFESSIONAL SERVICES NOT ELSEWHERE CLAS	\$1,359.63
THOMSON WEST TCD	City Attorney	PROFESSIONAL SERVICES NOT ELSEWHERE CLAS	\$141.83
<i>THOMSON WEST TCD - Total For City Attorney</i>			\$1,501.46

THOMSON WEST TCD - ALL DEPARTMENTS**\$1,501.46****TOOL PLANET**

TOOL PLANET	Buildings & Structures Fund	Repair part for BAS tools	\$37.03
-------------	-----------------------------	---------------------------	---------

<i>TOOL PLANET - Total For Buildings & Structures Fund</i>			<i>\$37.03</i>
--	--	--	----------------

TOOL PLANET - ALL DEPARTMENTS**\$37.03****TOP OFFICE PRODUCTS**

TOP OFFICE PRODUCTS	City Attorney	STATIONERY,OFFICE SUPPLIES,PRINTING AND	\$161.37
---------------------	---------------	---	----------

<i>TOP OFFICE PRODUCTS - Total For City Attorney</i>			<i>\$161.37</i>
--	--	--	-----------------

TOP OFFICE PRODUCTS	Ft. Caspar Museum	Quarterly copy charge fee for copier/scanner	\$17.09
---------------------	-------------------	--	---------

<i>TOP OFFICE PRODUCTS - Total For Ft. Caspar Museum</i>			<i>\$17.09</i>
--	--	--	----------------

TOP OFFICE PRODUCTS	Municipal Court	Supplies	\$44.86
---------------------	-----------------	----------	---------

<i>TOP OFFICE PRODUCTS - Total For Municipal Court</i>			<i>\$44.86</i>
--	--	--	----------------

TOP OFFICE PRODUCTS	Water Distribution	MAY COPY CHARGES	\$94.19
---------------------	--------------------	------------------	---------

<i>TOP OFFICE PRODUCTS - Total For Water Distribution</i>			<i>\$94.19</i>
---	--	--	----------------

TOP OFFICE PRODUCTS - ALL DEPARTMENTS**\$317.51****TOWNSQUARE MEDIA CAS**

TOWNSQUARE MEDIA CAS	Balefill - Disposal & Landfill	Radio ads	\$765.00
----------------------	--------------------------------	-----------	----------

<i>TOWNSQUARE MEDIA CAS - Total For Balefill - Disposal & Landfill</i>			<i>\$765.00</i>
--	--	--	-----------------

TOWNSQUARE MEDIA CAS	Sewer Stormwater	Radio advertising	\$496.00
----------------------	------------------	-------------------	----------

<i>TOWNSQUARE MEDIA CAS - Total For Sewer Stormwater</i>			<i>\$496.00</i>
--	--	--	-----------------

TOWNSQUARE MEDIA CAS	Sewer Wastewater Collection	Radio advertising	\$32.00
----------------------	-----------------------------	-------------------	---------

<i>TOWNSQUARE MEDIA CAS - Total For Sewer Wastewater Collection</i>			<i>\$32.00</i>
---	--	--	----------------

TOWNSQUARE MEDIA CAS - ALL DEPARTMENTS**\$1,293.00****TRI STATE OIL RECLAI**

TRI STATE OIL RECLAI	Balefill - Diversion & Special	antifreeze pickup recycling	\$732.00
----------------------	--------------------------------	-----------------------------	----------

<i>TRI STATE OIL RECLAI - Total For Balefill - Diversion & Special</i>			<i>\$732.00</i>
--	--	--	-----------------

TRI STATE OIL RECLAI - ALL DEPARTMENTS**\$732.00**

TRISHA SORENSEN

TRISHA SORENSEN	City Council	Divider tarp in baler	\$261.00
<i>TRISHA SORENSEN - Total For City Council</i>			<i>\$261.00</i>

TRISHA SORENSEN - ALL DEPARTMENTS **\$261.00**

TRUSTY-COOK

TRUSTY-COOK	Fire-EMS Training	Hammers	\$210.00
<i>TRUSTY-COOK - Total For Fire-EMS Training</i>			<i>\$210.00</i>

TRUSTY-COOK - ALL DEPARTMENTS **\$210.00**

TWEED'S WHOLESale

TWEED'S WHOLESale	Rec Center - Operations	custodial	\$779.12
<i>TWEED'S WHOLESale - Total For Rec Center - Operations</i>			<i>\$779.12</i>

TWEED'S WHOLESale - ALL DEPARTMENTS **\$779.12**

TYLER TECHNOLOGIES I

TYLER TECHNOLOGIES I	Balefill - Disposal & Landfill	Tyler Conversion	\$70.00
TYLER TECHNOLOGIES I	Balefill - Disposal & Landfill	Tyler Conversion	\$28.00
TYLER TECHNOLOGIES I	Balefill - Disposal & Landfill	Tyler conversion	\$47.25
TYLER TECHNOLOGIES I	Balefill - Disposal & Landfill	Tyler conversion	\$504.00
TYLER TECHNOLOGIES I	Balefill - Disposal & Landfill	Tyler Conversion	\$420.00

TYLER TECHNOLOGIES I - Total For Balefill - Disposal & Landfill *\$1,069.25*

TYLER TECHNOLOGIES I	Capital Projects Fund	Tyler Conversion	\$483.00
TYLER TECHNOLOGIES I	Capital Projects Fund	Tyler conversion	\$815.06
TYLER TECHNOLOGIES I	Capital Projects Fund	Tyler conversion	\$8,694.00
TYLER TECHNOLOGIES I	Capital Projects Fund	Tyler Conversion	\$7,245.00
TYLER TECHNOLOGIES I	Capital Projects Fund	Tyler Conversion	\$1,207.50

TYLER TECHNOLOGIES I - Total For Capital Projects Fund *\$18,444.56*

TYLER TECHNOLOGIES I	Refuse - Residential	Tyler conversion	\$756.00
TYLER TECHNOLOGIES I	Refuse - Residential	Tyler Conversion	\$105.00
TYLER TECHNOLOGIES I	Refuse - Residential	Tyler conversion	\$70.88
TYLER TECHNOLOGIES I	Refuse - Residential	Tyler Conversion	\$42.00
TYLER TECHNOLOGIES I	Refuse - Residential	Tyler Conversion	\$630.00

<i>TYLER TECHNOLOGIES I - Total For Refuse - Residential</i>			<i>\$1,603.88</i>
TYLER TECHNOLOGIES I	Regional Water Operations	Tyler conversion	\$126.00
TYLER TECHNOLOGIES I	Regional Water Operations	Tyler Conversion	\$105.00
TYLER TECHNOLOGIES I	Regional Water Operations	Tyler Conversion	\$17.50
TYLER TECHNOLOGIES I	Regional Water Operations	Tyler conversion	\$11.81
TYLER TECHNOLOGIES I	Regional Water Operations	Tyler Conversion	\$7.00
<i>TYLER TECHNOLOGIES I - Total For Regional Water Operations</i>			<i>\$267.31</i>
TYLER TECHNOLOGIES I	Sewer Wastewater Collection	Tyler Conversion	\$525.00
TYLER TECHNOLOGIES I	Sewer Wastewater Collection	Tyler conversion	\$630.00
TYLER TECHNOLOGIES I	Sewer Wastewater Collection	Tyler conversion	\$59.06
TYLER TECHNOLOGIES I	Sewer Wastewater Collection	Tyler Conversion	\$87.50
TYLER TECHNOLOGIES I	Sewer Wastewater Collection	Tyler Conversion	\$35.00
<i>TYLER TECHNOLOGIES I - Total For Sewer Wastewater Collection</i>			<i>\$1,336.56</i>
TYLER TECHNOLOGIES I	Water Distribution	Tyler Conversion	\$77.00
TYLER TECHNOLOGIES I	Water Distribution	Tyler conversion	\$129.94
TYLER TECHNOLOGIES I	Water Distribution	Tyler conversion	\$1,386.00
TYLER TECHNOLOGIES I	Water Distribution	Tyler Conversion	\$192.50
TYLER TECHNOLOGIES I	Water Distribution	Tyler Conversion	\$1,155.00
<i>TYLER TECHNOLOGIES I - Total For Water Distribution</i>			<i>\$2,940.44</i>
TYLER TECHNOLOGIES I	WWTP Operations	Tyler Conversion	\$70.00
TYLER TECHNOLOGIES I	WWTP Operations	Tyler conversion	\$504.00
TYLER TECHNOLOGIES I	WWTP Operations	Tyler Conversion	\$28.00
TYLER TECHNOLOGIES I	WWTP Operations	Tyler Conversion	\$420.00
TYLER TECHNOLOGIES I	WWTP Operations	Tyler conversion	\$47.25
<i>TYLER TECHNOLOGIES I - Total For WWTP Operations</i>			<i>\$1,069.25</i>
TYLER TECHNOLOGIES I - ALL DEPARTMENTS			\$26,731.25

UNIFORMS 2 GEAR

UNIFORMS 2 GEAR	Police Administration	Weather Tech jacket, embroider	\$125.38
<i>UNIFORMS 2 GEAR - Total For Police Administration</i>			<i>\$125.38</i>

UNIFORMS 2 GEAR - ALL DEPARTMENTS **\$125.38**

UNION WIRELESS

UNION WIRELESS	Water Tanks	Upper Rock Creek Reservoir SCADA & Cell Phon	\$94.89
----------------	-------------	--	---------

UNION WIRELESS - Total For Water Tanks \$94.89

UNION WIRELESS - ALL DEPARTMENTS \$94.89

UPS 0000008F045W230

UPS 0000008F045W230 Regional Water Operations ship Lab Test \$137.69

UPS 0000008F045W230 - Total For Regional Water Operations \$137.69

UPS 0000008F045W230 - ALL DEPARTMENTS \$137.69

URGENT CARE OF CASPE

URGENT CARE OF CASPE Property Insurance Fund MEDICAL SERVICES & HEALTH PRACTITIONERS \$2,800.00

URGENT CARE OF CASPE - Total For Property Insurance Fund \$2,800.00

URGENT CARE OF CASPE - ALL DEPARTMENTS \$2,800.00

US EPA RTP - FINANCE

US EPA RTP - FINANCE Capital Projects Fund Brownfields US EPA Refund 17-036 \$6,803.50

US EPA RTP - FINANCE - Total For Capital Projects Fund \$6,803.50

US EPA RTP - FINANCE - ALL DEPARTMENTS \$6,803.50

USPS PO 5715580478

USPS PO 5715580478 Balefill - Disposal & Landfill SLIB PROMISSORY NOTE \$7.60

USPS PO 5715580478 - Total For Balefill - Disposal & Landfill \$7.60

USPS PO 5715580478 Cemetery POSTAGE STAMPS OFFICE USE \$55.00

USPS PO 5715580478 - Total For Cemetery \$55.00

USPS PO 5715580478 - ALL DEPARTMENTS \$62.60

USPS PO 5715580945

USPS PO 5715580945 Water Administration POSTAGE STAMPS & 201 MOC AGENDA PACKET \$116.40

USPS PO 5715580945 - Total For Water Administration \$116.40

USPS PO 5715580945 - ALL DEPARTMENTS \$116.40

USPS PO 5762700491

USPS PO 5762700491	Water Distribution	POSTAGE STAMPS	\$550.00
<i>USPS PO 5762700491 - Total For Water Distribution</i>			<i>\$550.00</i>
USPS PO 5762700491 - ALL DEPARTMENTS			\$550.00

VERIZON WIRELESS

VERIZON WIRELESS	Code Enforcement	May 2020 acct. 942107055-00001	\$255.95
<i>VERIZON WIRELESS - Total For Code Enforcement</i>			<i>\$255.95</i>
VERIZON WIRELESS	Metro Animal Shelter	May 2020	\$52.02
<i>VERIZON WIRELESS - Total For Metro Animal Shelter</i>			<i>\$52.02</i>
VERIZON WIRELESS	Public Safety Communication	May 2020	\$80.04
VERIZON WIRELESS	Public Safety Communication	Command bus June	\$123.73
<i>VERIZON WIRELESS - Total For Public Safety Communications</i>			<i>\$203.77</i>
VERIZON WIRELESS - ALL DEPARTMENTS			\$511.74

VRC COMPANIES LLC

VRC COMPANIES LLC	Police Administration	February 2020	\$286.55
VRC COMPANIES LLC	Police Administration	May 2020	\$189.00
VRC COMPANIES LLC	Police Administration	June 2020	\$158.76
<i>VRC COMPANIES LLC - Total For Police Administration</i>			<i>\$634.31</i>
VRC COMPANIES LLC - ALL DEPARTMENTS			\$634.31

VZWRLSS BILL PAY VB

VZWRLSS BILL PAY VB	Aquatics - Pool	Internet at Outdoor Pools	\$600.15
<i>VZWRLSS BILL PAY VB - Total For Aquatics - Pool</i>			<i>\$600.15</i>
VZWRLSS BILL PAY VB - ALL DEPARTMENTS			\$600.15

VZWRLSS IVR VB

VZWRLSS IVR VB	Cemetery	TELECOMMUNICATION SERV.INCLUD. LOCAL/L.	\$40.01
VZWRLSS IVR VB	Cemetery	TELECOMMUNICATION SERV.INCLUD. LOCAL BA	\$40.01
<i>VZWRLSS IVR VB - Total For Cemetery</i>			<i>\$80.02</i>
VZWRLSS IVR VB	Parks - Parks Maint.	Irrigation phones and parks jetpacks	\$488.24
<i>VZWRLSS IVR VB - Total For Parks - Parks Maint.</i>			<i>\$488.24</i>
VZWRLSS IVR VB	Sewer Wastewater Collection	remote device data	\$73.28

<i>VZWRLSS IVR VB - Total For Sewer Wastewater Collection</i>			<i>\$73.28</i>
VZWRLSS IVR VB	Streets	Monthly charge for Streets on call and Traffic ho	\$65.61
<i>VZWRLSS IVR VB - Total For Streets</i>			<i>\$65.61</i>
VZWRLSS IVR VB	Water Distribution	TELECOMMUNICATION SERV.INCLUD. LOCAL/L.	\$277.67
<i>VZWRLSS IVR VB - Total For Water Distribution</i>			<i>\$277.67</i>
VZWRLSS IVR VB	WWTP Operations	TELECOMMUNICATION SERV.INCLUD. LOCAL/L.	\$144.99
<i>VZWRLSS IVR VB - Total For WWTP Operations</i>			<i>\$144.99</i>
VZWRLSS IVR VB - ALL DEPARTMENTS			\$1,129.81

VZWRLSS MY VZ VB P

VZWRLSS MY VZ VB P	Fire-EMS Administration	Verizon cell phone bill for April	\$2,037.73
VZWRLSS MY VZ VB P	Fire-EMS Administration	Verizon Air card bill for April	\$120.03
<i>VZWRLSS MY VZ VB P - Total For Fire-EMS Administration</i>			<i>\$2,157.76</i>
VZWRLSS MY VZ VB P	Golf - Operations	Cellular service for Ipad use	\$80.02
<i>VZWRLSS MY VZ VB P - Total For Golf - Operations</i>			<i>\$80.02</i>
VZWRLSS MY VZ VB P	Regional Water Operations	WTP Operator Cell Phone	\$40.41
<i>VZWRLSS MY VZ VB P - Total For Regional Water Operations</i>			<i>\$40.41</i>
VZWRLSS MY VZ VB P - ALL DEPARTMENTS			\$2,278.19

WAL-MART #1617

WAL-MART #1617	Aquatics - Pool	Supplies for outdoor pools	\$68.93
<i>WAL-MART #1617 - Total For Aquatics - Pool</i>			<i>\$68.93</i>
WAL-MART #1617	Buildings & Structures Fund	Custodial Supplies for City Hall	\$18.85
WAL-MART #1617	Buildings & Structures Fund	Trays for social distancing of Council members i	\$279.08
<i>WAL-MART #1617 - Total For Buildings & Structures Fund</i>			<i>\$297.93</i>
WAL-MART #1617	Human Resources	Chili Skate Night Supplies	\$41.04
<i>WAL-MART #1617 - Total For Human Resources</i>			<i>\$41.04</i>
WAL-MART #1617	Parks - Athletic Maint.	sunscreen, Bug Spray, Batteries for Metal Detec	\$67.44
<i>WAL-MART #1617 - Total For Parks - Athletic Maint.</i>			<i>\$67.44</i>
WAL-MART #1617	Rec Center - Classes	GROCERY STORES, SUPERMARKETS	\$33.43
<i>WAL-MART #1617 - Total For Rec Center - Classes</i>			<i>\$33.43</i>
WAL-MART #1617	Rec Center - Operations	GROCERY STORES, SUPERMARKETS	\$148.07
<i>WAL-MART #1617 - Total For Rec Center - Operations</i>			<i>\$148.07</i>
WAL-MART #1617	Water Distribution	DEF	\$157.60

WAL-MART #1617 - Total For Water Distribution \$157.60

WAL-MART #1617 - ALL DEPARTMENTS \$814.44

WAL-MART #3778

WAL-MART #3778 Fire-EMS Operations Water for Engine Co. during Protest Operaions \$44.14

WAL-MART #3778 - Total For Fire-EMS Operations \$44.14

WAL-MART #3778 Fire-EMS Prevent & Inspect SD Cards for Drone response to protests \$79.44

WAL-MART #3778 - Total For Fire-EMS Prevent & Inspect \$79.44

WAL-MART #3778 Water Tanks SAMPLING NOTEBOOKS & DIVIDERS \$10.82

WAL-MART #3778 - Total For Water Tanks \$10.82

WAL-MART #3778 - ALL DEPARTMENTS \$134.40

WAMCO LABS, INC.

WAMCO LABS, INC. WWTP Operations WYPDES DMRQA Study 40 WET test \$380.00

WAMCO LABS, INC. - Total For WWTP Operations \$380.00

WAMCO LABS, INC. - ALL DEPARTMENTS \$380.00

WARDWELL WATER & SEW

WARDWELL WATER & SEW RWS - Booster Stations June water charge \$126.18

WARDWELL WATER & SEW - Total For RWS - Booster Stations \$126.18

WARDWELL WATER & SEW - ALL DEPARTMENTS \$126.18

WEAR PARTS INC

WEAR PARTS INC Buildings & Structures Fund Parts for PV Pool Filter \$30.73

WEAR PARTS INC - Total For Buildings & Structures Fund \$30.73

WEAR PARTS INC Water Distribution Wand repair parts \$4.95

WEAR PARTS INC - Total For Water Distribution \$4.95

WEAR PARTS INC WWTP Operations Shop tools \$27.90

WEAR PARTS INC - Total For WWTP Operations \$27.90

WEAR PARTS INC - ALL DEPARTMENTS \$63.58

WENDY'S #6911

WENDY'S #6911	Fire-EMS Operations	Food for protest operations	\$95.48
<i>WENDY'S #6911 - Total For Fire-EMS Operations</i>			<i>\$95.48</i>
WENDY'S #6911 - ALL DEPARTMENTS			\$95.48

WEST PLAINS ENGINEER

WEST PLAINS ENGINEER	Capital Projects Fund	Goodstein Parking Electrical	\$500.00
<i>WEST PLAINS ENGINEER - Total For Capital Projects Fund</i>			<i>\$500.00</i>
WEST PLAINS ENGINEER	Perpetual Care Urban Forestr	CEC fire alarm and sprinkler 17-073	\$1,500.00
<i>WEST PLAINS ENGINEER - Total For Perpetual Care Urban Forestry</i>			<i>\$1,500.00</i>
WEST PLAINS ENGINEER - ALL DEPARTMENTS			\$2,000.00

WESTERN STATES FIRE

WESTERN STATES FIRE	Hogadon - Operations	Annual Fire suppression inspection	\$805.00
<i>WESTERN STATES FIRE - Total For Hogadon - Operations</i>			<i>\$805.00</i>
WESTERN STATES FIRE	Regional Water Operations	Repair made from Annual maint 2020	\$1,355.00
WESTERN STATES FIRE	Regional Water Operations	Repair made from Annual maint 2020	\$1,420.00
<i>WESTERN STATES FIRE - Total For Regional Water Operations</i>			<i>\$2,775.00</i>
WESTERN STATES FIRE - ALL DEPARTMENTS			\$3,580.00

WESTERN WATER CONSUL

WESTERN WATER CONSUL	Capital Projects Fund	K street rehab 15-51	\$355.00
WESTERN WATER CONSUL	Capital Projects Fund	Midwest Elm to Walnut Construc	\$3,379.88
WESTERN WATER CONSUL	Capital Projects Fund	Digital As-Built Process Updat	\$1,002.00
WESTERN WATER CONSUL	Capital Projects Fund	Midwest recon, elm to walnut 18-066	\$533.50
WESTERN WATER CONSUL	Capital Projects Fund	K Street Phase 2A DesignCA	\$10,956.75
<i>WESTERN WATER CONSUL - Total For Capital Projects Fund</i>			<i>\$16,227.13</i>
WESTERN WATER CONSUL - ALL DEPARTMENTS			\$16,227.13

WESTLAND PARK-RED BU

WESTLAND PARK-RED BU	Sewer Fund	June sewer revenue	(\$345.20)
WESTLAND PARK-RED BU	Sewer Fund	May sewer revenue	(\$335.10)
WESTLAND PARK-RED BU	Sewer Fund	June sewer revenue	\$3,452.00
WESTLAND PARK-RED BU	Sewer Fund	May sewer revenue	\$3,351.00

<i>WESTLAND PARK-RED BU - Total For Sewer Fund</i>			\$6,122.70
WESTLAND PARK-RED BU	WWTP Revenue and Transfer	May sewer revenue	(\$1,540.42)
WESTLAND PARK-RED BU	WWTP Revenue and Transfer	June sewer revenue	(\$1,540.42)
<i>WESTLAND PARK-RED BU - Total For WWTP Revenue and Transfers</i>			(\$3,080.84)
WESTLAND PARK-RED BU - ALL DEPARTMENTS			\$3,041.86

Wired

Wired	Perpetual Care Fund	CEC Arena floor lighting 19-014	\$8,831.10
<i>Wired - Total For Perpetual Care Fund</i>			\$8,831.10
Wired - ALL DEPARTMENTS			\$8,831.10

WLC ENGINEERING - SU

WLC ENGINEERING - SU	Capital Projects Fund	Design & CA for Morad Park to	\$3,801.88
WLC ENGINEERING - SU	Capital Projects Fund	Industrial storm and street 19-068	\$20,302.60
WLC ENGINEERING - SU	Capital Projects Fund	Ridgecrest Zone 2-3 Waterline	\$3,004.41
<i>WLC ENGINEERING - SU - Total For Capital Projects Fund</i>			\$27,108.89
WLC ENGINEERING - SU	Engineering	Surveying	\$72.50
WLC ENGINEERING - SU	Engineering	Surveying	\$145.00
<i>WLC ENGINEERING - SU - Total For Engineering</i>			\$217.50
WLC ENGINEERING - SU	Water Distribution	Ridgecrest Zone 2-3 Waterline	\$7,725.64
<i>WLC ENGINEERING - SU - Total For Water Distribution</i>			\$7,725.64
WLC ENGINEERING - SU - ALL DEPARTMENTS			\$35,052.03

WM SUPERCENTER

WM SUPERCENTER	Aquatics - Pool	Supplies for out door pools	\$82.84
<i>WM SUPERCENTER - Total For Aquatics - Pool</i>			\$82.84
WM SUPERCENTER	Balefill - Disposal & Landfill	SYMPATHY CARD	\$1.97
<i>WM SUPERCENTER - Total For Balefill - Disposal & Landfill</i>			\$1.97
WM SUPERCENTER	Fire-EMS Prevent & Inspect	Walmart - Ice for Protest Operations	\$3.52
WM SUPERCENTER	Fire-EMS Prevent & Inspect	Walmart - Supplies for protest operations	\$72.08
WM SUPERCENTER	Fire-EMS Prevent & Inspect	Wlamart - Supplies for protest operations	\$3.52
<i>WM SUPERCENTER - Total For Fire-EMS Prevent & Inspect</i>			\$79.12
WM SUPERCENTER	Metro Animal Shelter	bacus canned food	\$82.08

<i>WM SUPERCENTER - Total For Metro Animal Shelter</i>			<i>\$82.08</i>
WM SUPERCENTER	Rec Center - Classes	GROCERY STORES, SUPERMARKETS	\$143.78
<i>WM SUPERCENTER - Total For Rec Center - Classes</i>			<i>\$143.78</i>
WM SUPERCENTER	Rec Center - Operations	GROCERY STORES, SUPERMARKETS	\$55.67
<i>WM SUPERCENTER - Total For Rec Center - Operations</i>			<i>\$55.67</i>
WM SUPERCENTER	Water Distribution	CLEANING SUPPLIES	\$46.04
<i>WM SUPERCENTER - Total For Water Distribution</i>			<i>\$46.04</i>
WM SUPERCENTER - ALL DEPARTMENTS			\$491.50

WWW.BIGHORNDDESIGN.CO

WWW.BIGHORNDDESIGN.CO	Police State Grants	victim witness volunteer shirts	\$68.00
WWW.BIGHORNDDESIGN.CO	Police State Grants	vw volunteer shirts/jackets	\$144.00
<i>WWW.BIGHORNDDESIGN.CO - Total For Police State Grants</i>			<i>\$212.00</i>
WWW.BIGHORNDDESIGN.CO - ALL DEPARTMENTS			\$212.00

WY. MACHINERY CO.

WY. MACHINERY CO.	Balefill - Baler Processing	R1889608, 609, 610, 613, 614 rental loader	\$25,491.85
<i>WY. MACHINERY CO. - Total For Balefill - Baler Processing</i>			<i>\$25,491.85</i>
WY. MACHINERY CO.	Balefill - Disposal & Landfill	LANDFILL EQUIP REPAIRS	\$764.10
WY. MACHINERY CO.	Balefill - Disposal & Landfill	LANDFILL EQUIP REPAIRS	\$2,120.71
WY. MACHINERY CO.	Balefill - Disposal & Landfill	LANDFILL EQUIP REPAIRS	\$3,198.88
WY. MACHINERY CO.	Balefill - Disposal & Landfill	LANDFILL EQUIP REPAIRS	\$4,408.48
<i>WY. MACHINERY CO. - Total For Balefill - Disposal & Landfill</i>			<i>\$10,492.17</i>
WY. MACHINERY CO.	Balefill - Diversion & Special	COMPACTOR REPAIRS	\$23,393.98
WY. MACHINERY CO.	Balefill - Diversion & Special	COMPACTOR REPAIRS	\$22,369.97
<i>WY. MACHINERY CO. - Total For Balefill - Diversion & Special</i>			<i>\$45,763.95</i>
WY. MACHINERY CO. - ALL DEPARTMENTS			\$81,747.97

WY. RENTS, LLC.

WY. RENTS, LLC.	Water Distribution	Vibrator stinger to pour flow fill under driveway	\$77.00
<i>WY. RENTS, LLC. - Total For Water Distribution</i>			<i>\$77.00</i>
WY. RENTS, LLC. - ALL DEPARTMENTS			\$77.00

WY. RETIREMENT SYSTE

WY. RETIREMENT SYSTE	Police Administration	Shannon cole contribution	\$10,052.82
<i>WY. RETIREMENT SYSTE - Total For Police Administration</i>			<i>\$10,052.82</i>
WY. RETIREMENT SYSTE - ALL DEPARTMENTS			\$10,052.82

WY. STATE BOARD OF P

WY. STATE BOARD OF P	Police Animal Control	Peters application	\$80.00
WY. STATE BOARD OF P	Police Animal Control	Tarbett Application	\$80.00
<i>WY. STATE BOARD OF P - Total For Police Animal Control</i>			<i>\$160.00</i>
WY. STATE BOARD OF P - ALL DEPARTMENTS			\$160.00

WYCOMP, INC.

WYCOMP, INC.	RWS - Guardian	Water sampling home test	\$1,116.00
<i>WYCOMP, INC. - Total For RWS - Guardian</i>			<i>\$1,116.00</i>
WYCOMP, INC. - ALL DEPARTMENTS			\$1,116.00

WYOMING BUILDING SUP

WYOMING BUILDING SUP	Golf - Operations	New building or building modification	\$8,870.00
<i>WYOMING BUILDING SUP - Total For Golf - Operations</i>			<i>\$8,870.00</i>
WYOMING BUILDING SUP - ALL DEPARTMENTS			\$8,870.00

WYOMING CAMERA

WYOMING CAMERA	Fire-EMS Prevent & Inspect	Canon 67	\$10.99
<i>WYOMING CAMERA - Total For Fire-EMS Prevent & Inspect</i>			<i>\$10.99</i>
WYOMING CAMERA	Ft. Caspar Museum	Shipping to Canon to repair camera	\$15.00
<i>WYOMING CAMERA - Total For Ft. Caspar Museum</i>			<i>\$15.00</i>
WYOMING CAMERA - ALL DEPARTMENTS			\$25.99

WYOMING LOW VOLTAGE

WYOMING LOW VOLTAGE	Golf - Operations	Install network rack.	\$740.00
<i>WYOMING LOW VOLTAGE - Total For Golf - Operations</i>			<i>\$740.00</i>

WYOMING LOW VOLTAGE	Police Administration	Shooting range	\$560.00
<i>WYOMING LOW VOLTAGE - Total For Police Administration</i>			<i>\$560.00</i>
WYOMING LOW VOLTAGE - ALL DEPARTMENTS			\$1,300.00

WYOMING STEEL & RECY

WYOMING STEEL & RECY	Balefill - Baler Processing	Recycling	\$382.00
<i>WYOMING STEEL & RECY - Total For Balefill - Baler Processing</i>			<i>\$382.00</i>
WYOMING STEEL & RECY	Refuse - Recycling	Recycling	\$5,970.00
<i>WYOMING STEEL & RECY - Total For Refuse - Recycling</i>			<i>\$5,970.00</i>
WYOMING STEEL & RECY - ALL DEPARTMENTS			\$6,352.00

XEROX CORPORATION

XEROX CORPORATION	Engineering	June copier	\$185.66
<i>XEROX CORPORATION - Total For Engineering</i>			<i>\$185.66</i>
XEROX CORPORATION - ALL DEPARTMENTS			\$185.66

CITYWIDE BILLS AND CLAIMS TOTAL **\$2,738,962.91**

I certify, under penalty of perjury, that this listing of vouchers and the items included therein for payment are correct and just in every respect.

SUBMITTED BY (Finance Dir) _____ DATE _____

DULY AUDITED BY (City Manager) _____ DATE _____

APPROVED BY (Mayor) _____ DATE _____

CITY of CASPER, WYOMING
 BILLS and CLAIMS ADDENDUM
 Council Meeting
 07/07/20

Additional Accounts Payable

06/18/20	Prewrits - utility refunds, reimbursements, petty cash, payroll vendors	4,740.89
	American Heritage Life In	293.21
	Keith McPheeters	100.00
	Adrian Martinez	170.74
	First Interstate Bank - Petty cash	700.00
	First Interstate Bank - Petty cash	225.00
	Natrona County Clerk	8,607.09
	Solsbury Hill LLC	53.59
	Ashley Cooley	51.88
	Adam Jerrard	9.44
	Ryan Schoonover	44.82
	Sara L. Kebler	75.00
	Trisha Youker	14.13
	Equity Brokers	49.60
	Chasity Jung	37.79
	Courtney Huggins	31.62
	Glendon Merrell	50,817.65
	State of Wy	<u>50,817.65</u>
		\$ 66,022.45
6/25/20	Prewrits - refund, reimbursements, recording fees, payroll vendors	
	Krista Clark	\$895.00
	Keith McPheeters	\$224.79
	Natrona Co. Clerk	\$135.00
	State of Wy	\$80.79
	State of Wy	\$768,218.15
	University of Wy - Cooperative	<u>\$24,753.25</u>
		\$ 794,306.98
7/2/20	Prewrits- Life insurance, Petty Cash, Utility Refunds	
	808-NCPERS GROUP LIFE INSURANCE	\$2,080.00
	ALTIG JOHN	\$43.90
	ANDREA LUCAS	\$75.00
	AXTELL HAILEY	\$6.94
	BACK TERESA	\$55.30
	BRANNAN JOSEPH	\$51.88
	BUNCE WILLIAM	\$158.86
	CRAGOE HAYDEN	\$40.07
	DEVRIES AVERY	\$16.79
	ELLER SYDNE	\$22.80
	FIRST INTERSTATE BANK - PETTY CASH	\$29.82
	FIRST INTERSTATE BANK - PETTY CASH	\$245.00
	FIRST INTERSTATE BANK - PETTY CASH	\$362.99
	FIRST INTERSTATE BANK - PETTY CASH	\$24.55
	FITZPATRICK STEVEN	\$13.40
	GLOVER NICH	\$44.05
	GOOD NEWS CHURCH	\$44.33
	JOAN WADE	\$67.70
	JOEL HERSHMAN	\$2,588.02
	KAC INVESTMENTS	\$53.59
	RAMSEY GAYLE	\$47.67
	RENEGADE SERVICES	\$50.74
	RICHARD NYQUIST	\$218.50
	ROBERTOS SHOP	\$41.75
	T & T PROPERTY ENTERPRISE	\$51.89
	TEAGUE STEPHEN	\$34.18
	VIEWPOINT GOVERNMENT SOLUTIONS, INC.	\$1,908.00
	WARREN TRACY	\$6.82
	WOOD AMANDA	<u>\$50.74</u>
		\$8,435.28

June 29, 2020

MEMO TO: City Council
J. Carter Napier, City Manager *JCN*

FROM: John Henley, City Attorney *JH*

SUBJECT: Proposed Ordinance amending various sections of Chapter 6.04 - Animal Care and Control of the Casper Municipal Code

Meeting Type & Date

Regular Council Meeting
July 7, 2020

Action type

Establish a date for the Public Hearing and First Reading

Recommendation

That Council, by minute action, establish a Public Hearing and First Reading on July 21, 2020 of the proposed Ordinance titled “An Ordinance Updating and Amending Sections 6.04.010, 6.04.040, 6.04.180, 6.04.210, 6.04.300, and 6.04.301 of the Casper Municipal Code.”

Summary

Ordinance 1-19 repealing and replacing Animal Care and Control Chapter 6.04 of the Code in its entirety was adopted February 19, 2019. Since that time Animal Control Officers, based on their experience, are requesting various changes and amendments to the Code.

Current proposed amendments to the Code address the following:

Section 6.04.010 – Definitions have been modified to add or change the definitions of “Aggressive Animal”, “Clean”, “Feral Cat”, “Proper Shelter”, and “Vicious Animal”, and

Modifications to Sections:

- 6.04.040 Keeping of pets, livestock or fowl; limitations.; (now changed to Keeping of pets, livestock or fowl; limitations.; feeding of non-domesticated animals prohibited,
- 6.04.180 Cruelty to animals—Unlawful acts designated,
- 6.04.210 Animals in Motor Vehicles - Unlawful acts (now changed to Neglect),
- 6.04.300 Vicious Animals Indicia (to be removed), and
- 6.04.301 Vicious and Dangerous Animals – Limitations and Prohibitions (now changed to Vicious and Aggressive Animals - Limitations and Prohibitions).

Find attached a *Proposed Amendment 1 to definition of "Attack"*. The proposed amendment incorporates some Council Members' concern at the June 23, 2020 work session.

Additionally, Section 6.04.210 D. 1. was modified after the June 23, 2020 work session to reduce the length of time animals may be tethered from no longer than ten hours in a twenty-four hour period, to no longer than five hours in a twenty-four hour period.

Other proposed amendments may be forthcoming dependent upon additional concerns or comments.

Financial Considerations

None

Oversight/Project Responsibility

John Henley, City Attorney (Ordinance Amendments)

Scott Schell, Police Department, Animal Protection Supervisor

Attachments

Proposed Ordinance Updating and Amending Sections 6.04.010, 6.04.040, 6.04.180, 6.04.210, 6.04.300, and 6.04.301 of the Caper Municipal Code

Proposed Amendment to Section 6.04.010 subsection 9. definition of "Attack".

ORDINANCE NO.

AN ORDINANCE UPDATING AND AMENDING SECTIONS 6.04.010, 6.04.040, 6.04.180, 6.04.210, 6.04.300, AND 6.04.301 OF THE CASPER MUNICIPAL CODE.

WHEREAS, Casper Municipal Code addressing animal care and control needs modification from time to time to provide for greater protection for animals; and,

WHEREAS, the Animal Code was repealed and replaced in its entirety in February of 2019, and since such time animal control officers have requested changes to the Code; and,

WHEREAS, the City is authorized to regulate and take measures to prevent conduct which disturbs or jeopardizes the public health, safety, and peace; and,

WHEREAS, it is in the best interest of the citizens of the City of Casper to promote responsible care and control of animals.

NOW, THEREFORE, BE IT ORDAINED BY THE GOVERNING BODY OF THE CITY OF CASPER, WYOMING: That the following sections of Chapter 6.04 of the Casper Municipal Code are hereby amended and replaced, and shall be codified as follows:

Quick reference guide: (to be removed after 2nd reading)

6.04.010 Definitions. Page 1-6

6.04.040 Keeping of pets, livestock or fowl; limitations.; feeding of non-domesticated animals prohibited. Page 7

6.04.180 Cruelty to animals—Unlawful acts designated. Page 7

6.04.210 Neglect Page 8

6.04.300 Reserved. ~~Vicious animals—indicia.~~ Page 10

6.04.301 ~~Vicious and Dangerous Aggressive Animals – Limitations and Prohibitions.~~ Page 11

6.04.010 - Definitions.

When used in this Chapter, words have their common meaning and in addition the following words, terms, and phrases, and their derivations have the following meanings:

1. “Abandon” means a person leaves an animal on public or private property without permission to ensure proper care and supervision. An animal that is left in the Metro Animal Shelter for seven (7) working days, shall be deemed abandoned.

2. “Aggressive Animal”

A. means any animal not on the owner of the animal’s property, that has attacked a domestic animal or livestock in such a manner that resulted in physical contact between the animals not necessarily requiring medical treatment to either animal, or;

B. any animal that has chased, approached or otherwise interacted with a human being, domestic animal or livestock in an intimidating or aggressive manner.

These behaviors shall be prima facia evidence that an animal(s) is aggressive and there is a rebuttable presumption that the animal(s) is aggressive.

~~2.3.~~ “Altered” means neutered; spayed or castrated.

~~3.4.~~ “Animal” means any live vertebrate creature, domestic or wild.

~~4.5.~~ “Animal control district” means the City of Casper, Wyoming.

~~6.5.~~ “Animal protection officer” means any person designated by the director as a special municipal officer who is qualified to perform such duties under this chapter and the laws of this state.

~~7.6.~~ “Animal services shelter” means any facility operated by a municipal agency, or its authorized agents for the purpose of housing, impounding or caring for animals held under the authority of this chapter or state law.

~~7.8.~~ “At large.”

a. The definition of “at large” in this Chapter, is subject to and subservient to Sections 6.04.301 to 6.04.303 of this Chapter addressing dangerous or vicious animals. For dangerous or vicious animals, any violation of Sections 6.04.301 to 6.04.303 are violations also of the “at large” provisions of this Chapter.

b. i. A non-vicious, non-dangerous animal is deemed "at large:"

(a) If it is off the owner’s property and not leashed or in an enclosed carrier;
or

(b) If it is on the owner’s property and not under the direct supervision of the owner or not confined to the extent that the animal cannot leave the boundaries of the property; examples of confinement are by use of fencing or other secure enclosures or by tethering.

b. ii. A non-dangerous or non-vicious animal shall not be considered "at large" when held and controlled by a person by means of a leash or chain of proper strength and length to control the action of the animal, or while confined within a vehicle. If the animal within a parked vehicle can extend its entire head outside the enclosed cabin compartment of the vehicle or beyond the side of a truck bed, that animal shall be deemed at large.

b. iii. A non-dangerous or non-vicious dog is not considered to be at large if within the interior of designated areas which permit dogs to be off leash, as established by the City of Casper.

b. iv. Under any circumstance, on a City-owned Golf Course.

9. “Attack” means an aggressive or violent action against a person or animal.

10. "Cage and aviary birds" means those exotic captive reared birds, such as parrots, exotic finches, and canaries, which are adapted to live and breed in a cage. For the purpose of this chapter the monk parakeet (*myiopsitta monachus*) is not a cage and aviary bird.
11. "Chicken" a domestic fowl kept for its production of eggs and meat.
12. "Circus" means any nonresident variety show which features animal acts.
13. "City-county health officer" means a representative of the Natrona County-City of Casper Health Department, or a health official designated by the Casper City Manager.
14. "Clean" means:
- A. The premises are free of feces and urine as to not cause offensive odors or unsanitary conditions in the enclosure(s), yard or surrounding areas.
 - B. Does not draw in flies or insects to the area and/or resulting in injury or illness to the animal(s).
 - A.C. The area is free of physical hazards and/or risks to the animal(s). (i.e. excessive items cluttering the property, broken or sharp objects.
- 13.15. "Commercial animal establishment" means any pet store, grooming shop, auction, riding school or stable, circus performing animal exhibition, kennel or other establishment in which animals are used for commercial purposes.
- 14.16. "Commercial purpose" means the keeping of animals for the purpose of profit.
- 15.17. "Control" means an animal which:
- a. is under a physical restraint so as to not be allowed to engage a passerby or other animal; such as a leash or in an enclosed carrier.
- 16.18. "Dangerous animal" means any animal under the totality of circumstances, which poses
 an unacceptable risk of injuring a human, a pet or property. Indicia of a dangerous animal shall include, but not be limited to, aggressive lunging, growling, snarling, nipping, bearing teeth.
- 17.19. "Director" means the City Manager or his/her designee.
- 18.20. "Direct supervision" as used in the definition of "at large," above, means: The owner of
 the animal is in the same area as the animal and not separated by any barrier; the owner must be able to immediately see and effectively call and manage the animal.
21. "Domesticated animals" means those individual animals which have been made tractable or tame.
- 19.22. "Feral Cat" means a cat that lives outdoors and has little or no human contact. They do not allow themselves to be handled or touched by humans and will run away if able. They typically remain hidden from humans, although some feral cats become more

comfortable with people who regularly feed them. Even with long-term attempts at socialization, feral cats usually remain fearful and avoidant of humans.

~~20.~~~~23.~~ “Isolation facility” means any place specified by the Director or his/her designee which is equipped with a pen or cage which isolates an animal from contact with other animals.

~~21.~~~~24.~~ “Kennel” or “cattery” means any premises wherein any person engages in the business of boarding, breeding, buying, letting for hire, training for a fee, or selling dogs or cats, or any residence or property on which is maintained more than three dogs and three cats more than six months of age. It is illegal to maintain a kennel or cattery contrary to the terms of this code, in a zone or location in which a kennel or cattery is not permitted.

~~22.~~~~25.~~ “License” means permission issued by the Director, or his/her designee, authorizing the holder to keep a dog or cat. An identification tag shall be issued for each animal licensed. A valid rabies vaccination is required to obtain a license.

~~23.~~~~26.~~ “License Tag” means a tag of a design prescribed by the Director, or his/her designee, which bears the corresponding number of the dog or cat’s license.

~~24.~~~~27.~~ “Licensing authority” means Metro Animal Services (MAS).

~~25.~~~~28.~~ “MAS” means Metro Animal Services

~~26.~~~~29.~~ “Microchip” means an identifying integrated circuit which is placed under the skin of an animal.

~~27.~~~~30.~~ “Owner” includes a person who owns, harbors, keeps, maintains or exercises control over an animal. Proof that a person is in control of a premise where an animal is usually kept, harbored or maintained shall establish a prima facie presumption that such person is the owner of such animal.

~~28.~~~~31.~~ “Proper shelter” means a structure with three (3) sides, a top and a bottom or a commercially manufactured structure, which includes an igloo styled house, designed and marketed to protect animals from outside elements. The shelter must have adequate ventilation and drainage which allows the animal to enter, stand, turn around and lie down in a natural manner. It shall be placed on the owner’s premises to effectively protect the animal from outside elements. Proper shelter includes circumstances where if the animal is provided at will access to inside the care taker’s residence or the animal has access to a structure through a commercial or homemade “dog door”.

~~29.~~~~32.~~ “Public nuisance” means any animal is considered a public nuisance if it:

- a. trespasses on school grounds, or
- b. damages private or public property, or
- c. interferes with passersby or a passing vehicle, to include bicycles, or

~~d.~~

~~e.~~ either individually or in concert, barks, whines, howls or otherwise makes noise in an

~~f.d.~~ excessive, continuous or untimely fashion, or

~~g.e.~~ interferes with the delivery of U.S. Mail or other delivery services, ~~or~~

~~h.f.~~ causes garbage which was previously placed in garbage or refuse container(s) to be strewn or deposited on private or public property.

~~30.33.~~ “Cat” A member of the feline family and shall not include feral cats, exotic wild cats, wild species of this family or hybrids thereof.

~~31.34.~~ “Dog” A member of the canine family, but shall not include wild species of this family, or any hybrid thereof.

~~32.35.~~ “Facilities for keeping” The pens, stalls, stables, corrals, feeding area, sheds and facilities of every kind where fowl, livestock or pets are penned, fed and/or protected from the weather. This shall not be interpreted to include a grazing area.

~~33.36.~~ “Fowl” includes feathered animals regardless of age, excluding parrots and chickens.

~~34.37.~~ “Grooming shop” A commercial establishment where animals are bathed, clipped, or otherwise groomed.

~~35.38.~~ “High Risk Rabies Vector” means raccoon, skunk, fox, coyote and bat

~~36.39.~~ “Impound” means to place an animal in the Metro Animal Shelter, or the taking into custody of an animal.

~~37.40.~~ “Licensed Veterinarian” A practitioner of veterinary medicine who holds a valid license

to practice their profession in the state in which they practice.

~~38.41.~~ “Livestock” Includes any species of equine, bovine, ovine, swine, caprine or any hybrid

thereof, regardless of age, sex, breed, size or purpose; inclusive of all ungulates.

~~39.42.~~ “Local Rabies Control Authority” The Metro Animal Protection Supervisor, as appointed by the Casper Chief of Police.

~~40.43.~~ “Parrot” Any of numerous tropical and semi-tropical birds of the order of Psittaciformes, characterized by short hooked bills, brightly colored plumage and in some species the ability to mimic human speech.

~~41.44.~~ “Pen or corral” An enclosure in which livestock are kept.

~~42.45.~~ “Performing animal exhibition” Any spectacle, display, act or event other than circuses,

in which performing animals are used.

~~43.46.~~ “Pet” Any animal normally kept for pleasure rather than utility, excluding those defined

as fowl, livestock or wild by this code.

~~44.47.~~ “Pet shop” Any person, partnership or corporation, whether operated separately or in connection with another business enterprise that buys, sells or boards any species of pets.

~~45.48.~~ “Premises” A parcel of land (one or more contiguous lots) owned, leased or controlled by one or more persons.

~~46.49.~~ “Quarantine” To detain and isolate due to suspected zoonosis or other communicable disease or in the interest of public health and safety.

~~47.50.~~ “Rabies certificate” means a certificate signed by a licensed veterinarian verifying that an animal is vaccinated against rabies, and which includes the date of immunization, the date that the immunization expires, and the type of vaccine used.

~~48.51.~~ “Tether or tethering” means to restrain a dog by tying the dog to any object or structure,

including, but not limited to, a house, tree, fence, post, pole, garage, or shed or similar structure or object, by any means, including, but not limited to, a chain, rope, cord, leash, or running line. “Tethering” shall not include using a leash to walk a dog.

~~49.52.~~ “Riding school or stable” Any place, which has available for hire, boarding and/or riding instruction, any horse, donkey or mule.

~~50.53.~~ “Sanitary” Any condition of good order and cleanliness.

~~51.54.~~ “Service Animal” means as defined in 28 C.F.R.35.104 and 28 C.F.R. 36.104, including a domesticated trained dog, that is owned in order to assist an individual with a disability. Examples of service animals are dogs that are individually trained to do work or perform tasks for the benefit of an individual with a disability, including physical, sensory, psychiatric, intellectual, or other mental disability. Tasks performed can include, among other things, pulling a wheelchair, retrieving dropped items, alerting a person to a sound, reminding a person to take medication, or pressing an elevator button. Emotional support animals and comfort animals are not service animals. The work or tasks performed by a service animal must be directly related to the individual’s disability. To be a service animal, there is no requirement for certified documentation of training or designation; it is the task for which the animal provides disability assistance which is determinative of whether an animal is a “service animal”. Conversely a doctor’s letter does not turn an animal into a service animal.

~~52.55.~~ “Veterinary hospital” means any establishment maintained and operated by a licensed veterinarian for surgery, wellness program, boarding, diagnosis and treatment of diseased and injured animals.

~~53.~~ A “vicious animal” means: ~~any animal or animals that constitute a physical threat to~~

~~54.~~ ~~human beings or other animals. Proof of the fact that an animal has bitten or attacked a~~

~~55.~~ ~~person or other animal at any place where that attacked or bitten person or animal is~~

~~56.~~ ~~legally entitled to be, shall be prima facie evidence that an animal is vicious and there is a rebuttable presumption that the attacking animal is a vicious animal.~~

~~A. Any animal(s) which has attacked a human being resulting in injury or death.~~

~~B. Any animal(s) who, while in a place it is not legally entitled to be, attacks or has attacked a domestic animal or livestock in such a manner that it results or resulted in~~

death or injury which subsequently results or resulted in a visit to a licensed veterinarian.

C. The animal's conduct is that of an "aggressive animal" and the animal has previously been declared an "aggressive animal".

These behaviors shall be prima facia evidence that an animal(s) is vicious and there is a rebuttable presumption that the animal(s) is vicious.

56.57. "Wild animal" or "exotic pet" means any live monkey (non-human primate), raccoon, skunk, fox, snake, leopard, panther, tiger, lion, lynx, coyote, wolf, crocodilian, any monitor exceeding three (3) feet in overall length or any animal which can normally be found in the wild state or any hybrid thereof. Venomous and poisonous animals shall be prohibited in the city limits of Casper, regardless of species or purpose.

57.58. "Working day" means a day that the Metro Animal Services Shelter is open to the public.

58.59. "Ungulate" means a hoofed mammal.

60. "Zoological garden" means any facility, other than a pet shop or kennel, displaying or exhibiting one or more of non-domesticated animal(s) by a person, partnership, corporation or government agency.

6.04.040 - Keeping of pets, livestock or fowl; limitations.; feeding of non-domesticated animals prohibited.

A. Number permitted.

1. It shall be unlawful for any person to keep more than three cats and three dogs on any premises within the City limits of Casper, except kennels and catteries will be allowed in the City only in areas properly zoned for this type of business.
2. No fowl or livestock shall be kept on any lot or tract of land located in a residentially zoned area of the City; this applies to any and all ungulates.
3. No more than ten of any other pet shall be permitted on a single premises, excluding fish, rodents and small cage birds.

B. Fencing Requirements.

1. Unless otherwise provided, where fencing is required by this chapter, it shall be at least three feet in height and constructed of a material sufficient to confine the animal.
2. Escape of an animal covered by this chapter shall be presumptive evidence that the owner's fence does not sufficiently control the animal.

C. Feeding of Non-domesticated Animals Prohibited.

1. It shall be unlawful for any person to provide shelter, feed, or to otherwise entice any non-domesticated animal(s) to gather or frequent, with the exception of birds and squirrels, but including feral cats, onto any public area or onto the property of the person, were such animals are not deemed or claimed to be the property of the person or the caretaker thereof. This shall not apply to property owners attempting to trap non-domesticated animal(s) already coming onto their property by use of a live box trap.

6.04.180 - Cruelty to animals—Unlawful acts designated.

It is a violation of this ordinance to inflict cruelty referenced as follows, upon an animal ~~as stated herein~~:

- A. No person shall override, overload, drive when overloaded, overwork, torture or torment an animal, or deprive an animal of necessary sustenance.
- B. No person shall cruelly beat, mutilate or kill an animal unless specifically authorized by law.
- C. No person shall cause, instigate, be a spectator at or permit a dogfight, cockfight, bullfight (bloodless or otherwise), or other combat involving animals.
- D. No person shall abandon any animal, but may relinquish the animal and ownership rights in the animal to an animal shelter or other qualified caretaker.
- ~~E. No person shall fail to provide his/her animal with sufficient good and wholesome food and clean water, proper shelter to protect it from the weather (including sunlight), veterinary care when needed to prevent suffering, and with humane care and treatment.~~
- ~~F. It is unlawful to annoy, bait, harass, torment or tease any confined or chained animal.~~
- G.E. Unless specifically authorized by law, no person shall willfully maim or disfigure any domestic or wild animal, or administer poison, or cause to be ingested any foreign object to any such animal, or expose any poisonous substance with the intent that it shall be taken by any animal, except pests of public health concern. The provisions of this section and Sections 6.04.190, 6.04.200, subsections B and C of Section 6.04.210 and Sections 6.04.220 and 6.04.250 do not in any way limit the right of a police officer or animal protection officer to humanly euthanize any wild or domestic animal if such officer determines that there is a reasonable danger to the public safety or if the animal is sick or injured to an extent that humanly euthanizing the animal is the appropriate action to take.
- ~~H. No person shall tether a dog while the dog is outdoors, or within any structure that is not the dog owner's home, except when all of the following conditions are met:~~

- ~~1. The dog is in visual range of a responsible party.~~
- ~~2. The tether is connected to the dog by a well fitted, buckle type collar or a body harness made of nylon or leather, not less than one inch in width.~~
- ~~3. The dog is tethered in such a manner as to prevent injury, strangulation, or entanglement.~~
- ~~4. The tether shall confine the dog to the owner's property.~~
- ~~5. The dog has access to water, shelter, and dry ground.~~
- ~~6. The dog is at least six months of age. Puppies shall not be tethered.~~
- ~~7. No dog shall be tethered for more than 2 hours in any 24-hour period.~~

~~F. The owner of every Domesticated animals shall be required to provided with clean living such animal with sanitary living conditions, including by the timely removing of animal waste from an interior or exterior pen, shelter, yard or other keeping area. All animal waste must be disposed of in an approved container.~~

~~G. No person shall knowingly harass or torment any confined or restrained animal(s). This includes but is not limited to harassing, yelling in a harassing manner, throwing objects at or towards, making gestures toward or any other similar behavior used towards the animal(s) to elicit a reaction or cause undue stress of said animal(s).~~

6.04.210 - Neglect Animals in motor vehicles — Unlawful acts.

~~A. No person shall leave a dog unattended in the bed of a pickup truck in a public parking area unless the dog is restrained in such a manner as to prevent the dog from making physical contact with a pedestrian who is passing the truck in a place where that pedestrian is legally entitled to be; if a dog is found to be not restrained as stated, the dog is "at large."~~

~~B.—~~

~~C. It is considered cruel and therefore unlawful for a person to leave an animal unattended in a motor vehicle with excessive temperatures. When the temperature is sixty (60) degrees Fahrenheit or above, unless, in the opinion of the officer, adequate ventilation and water are provided, there exist the presence of a potential problem and APOs and other law enforcement may undertake investigatory steps and actions appropriate under the circumstances to protect the life of any animal confined in such a vehicle.~~

~~D.—~~

~~E. No person shall carry an animal in a motorized vehicle in an inhumane or unsafe manner.~~

A. It is unlawful for any animal(s) to be left in a motor vehicle when the outside ambient temperature is above seventy (70) degrees Fahrenheit or below freezing, except where, in the considered opinion of the Animal Protection Officer, the animal is provided adequate accommodations for the temperatures. (i.e. water, ventilation, heat, air conditioning and bedding). Animal Protection Officers and other law enforcement may undertake investigatory steps and actions, appropriate under the circumstances, to protect the life of any animal confined in such a vehicle.

- B. Animals must have access to water and proper shelter at all times unless, in the considered opinion of the Animal Protection Officer, the animal is of a species and breed which is generally recognized as being capable of self-maintaining a safe body temperature, or where the owner has taken precautions to accommodate for temperature and weather.
- C. The shelter, all bedding, and any spaces accessible to the animal(s) shall be kept reasonably clean.
- D. Animals may be tethered as a means of confinement only in accordance with the following:
1. Animals may not be tethered longer than five (5) hours in any twenty-four (24) hour period.
 2. Animals may not be tethered on a line less than five (5) times their body length as measured from the tip of the nose to the tip of the tail, or twelve (12) feet, whichever is less; the safety of the animal shall not be at risk by the use of a tether.
 3. Animals may not be tethered on a line that weighs more than one quarter of the animal's body weight.
 4. The tether shall be strong enough to restrain the animal.
- E. Animal(s) must be reasonably groomed to prevent skin irritation, skin damage, skin infection and hazardous entanglement of foreign bodies on the animal.
- F. It shall be unlawful for a person to transport a living animal(s) upon the hood, fender, running board, or other external part of a moving vehicle. For the purposes of this section, the traditional truck bed, consisting of three (3) vertical walls and a closed tailgate, shall not be considered an external part of a moving vehicle.

6.04.300 – ~~Reserved. Vicious animals – indicia.~~

~~Indicia of vicious animals includes, but is not limited to, animals that:~~

~~Have bitten, attacked, endangered or inflicted injury on a human being on public or private property;~~

~~Have injured or killed a domestic animal;~~

~~Have interfered with delivery of mail by the United States Postal Service, or other delivery services as attested to by the delivery carrier or witnessed by authorities;~~

~~Have followed or chased a person upon the streets, sidewalks, or any public grounds in a menacing fashion or with apparent attitude of attack.~~

6.04.301 – Vicious and ~~Dangerous~~ Aggressive Animals – Limitations and Prohibitions.

It shall be unlawful to keep, possess, or harbor a ~~dangerous or~~ vicious or aggressive animal within City limits as follows:

No person shall have, keep, harbor, or allow to be upon any premises occupied by him/her, or in or under his/her charge or control, any vicious ~~or dangerous or aggressive~~ animal, or any animal that may manifest a disposition to bite anyone, without having the animal properly restrained to prevent the animal from inflicting damage upon any person or property (See 6.04.30220(~~Dd~~)). When off the premises of its owner, such animal shall be securely caged or muzzled, and restrained by a secure collar and leash not to exceed three (3) feet in length. The leash shall be of sufficient strength to prevent escape and shall be under the direct control of the owner.

PASSED on 1st reading the ____ day of _____, 2020

PASSED on 2nd reading the ____ day of _____, 2020

PASSED, APPROVED, AND ADOPTED on third and final reading the _____ day of _____, 2020.

APPROVED AS TO FORM:

ATTEST:

CITY OF CASPER, WYOMING
A Municipal Corporation

Fleur Tremel
City Clerk

Steven K. Freel
Mayor

Proposed Amendment 1 to definition of “Attack” (Regular Meeting July 7, 2020)

I move to amend 6.04.010 – Definitions.:

Current subsection 9. Definition of “Attack” to read as follows:

9. “Attack” means an aggressive or violent action against a person or animal. **If the animal being accused of an attack, was responding to an aggressive or violent action by a person or animal not on the person’s property or the animal owner’s property, this circumstance should be considered as a possible mitigating factor by the Court.**

June 5, 2020

MEMO TO: J. Carter Napier, City Manager *jal*
FROM: Liz Becher, Community Development Director *LB*
SUBJECT: Public Hearing for Consideration of an Ordinance to Vacate West 8th Street, from South David Street to South Center Street

Meeting Type & Date:

Regular Council Meeting, July 7, 2020

Action Type:

Ordinance and Public Hearing

Recommendation:

That Council, by ordinance, approve the vacation of West 8th Street from South David Street to South Center Street.

Summary:

The Natrona County School District has requested a vacation of West 8th Street between South David Street and South Center Street. The portion of street proposed for vacation is located between Park School on the south, and the School District's bus hub on the north. The plan for the vacated street is to use it for additional parking, and to close it off to through traffic to improve pedestrian and student safety. The recently-approved site plan for Park School renovations included the closure of the street in its design. The School District is exploring the creation of a parent-student drop-off area along either West 9th Street or South Center Street.

The School District has provided a signed petition with signatures of a majority of the property owners, who own a majority of the property proposed for vacation, and extending three hundred feet (300') in all directions. In addition, the District has obtained easement releases from all affected Casper utility providers.

Financial Considerations:

Wyoming State Statute 15-4-305 states that the City may demand and receive the value of the land vacated as consideration for the vacation, if desired.

Oversight/Project Responsibility:

Craig Collins, City Planner, is tasked with processing vacation requests.

Attachments:

Exhibit for Vacation
Ordinance

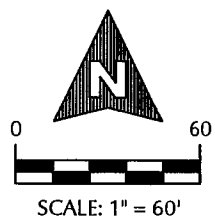
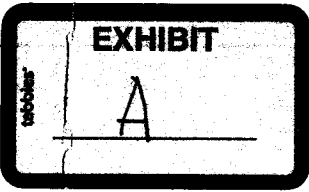
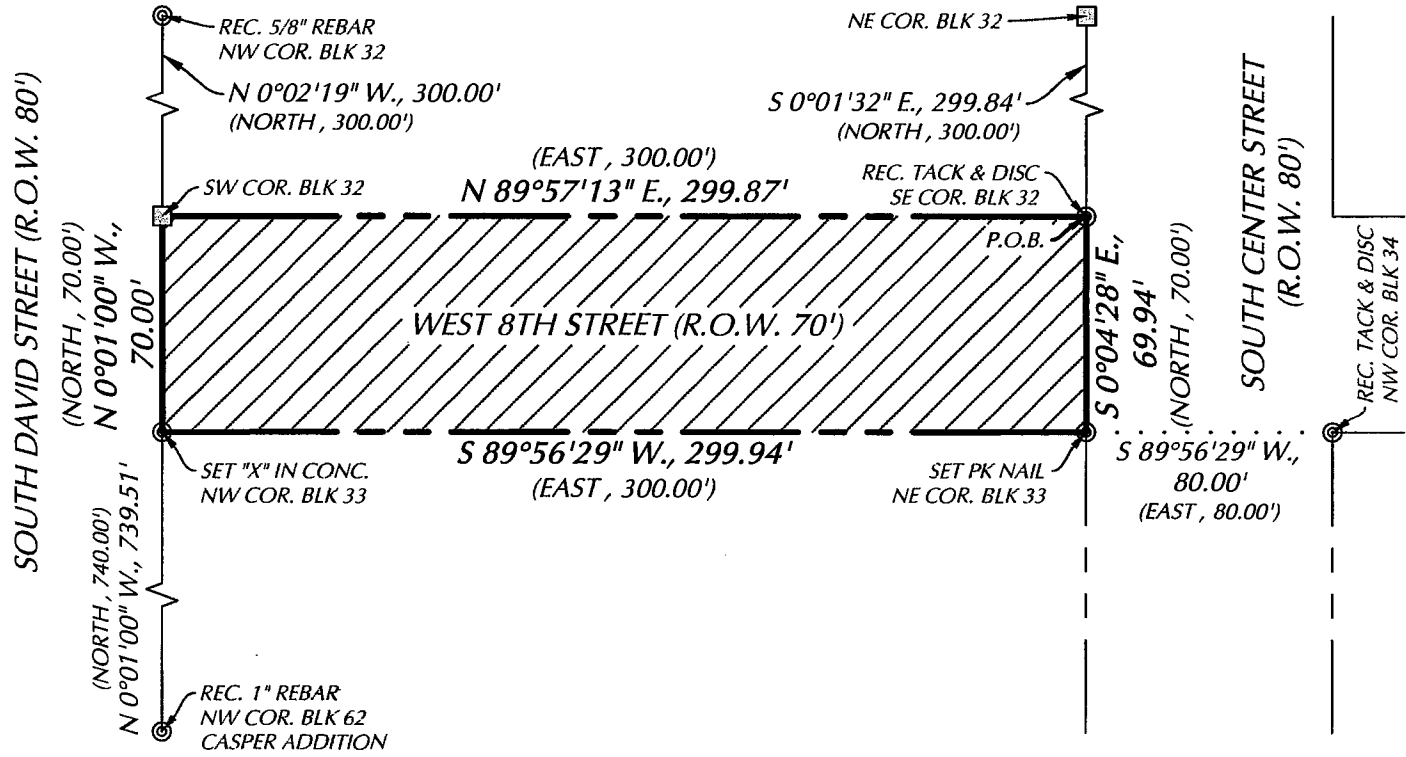

LEGEND

	RECOVERED ALUMINUM CAP
	RECOVERED/SET MONUMENT AS NOTED
	SITE BOUNDARY
	LOT LINES
	MEASURED RECORD

NOTES:
 1. BASIS OF BEARING IS AN ASSUMED BEARING OF NORTH AS DETERMINED BY GPS (WGS84) AT 42°50'33.90083" N & 106°19'31.20071" W.

LEGAL DESCRIPTION:

A PART OF WEST 8TH STREET BEING SOUTH OF BLOCK 32 AND NORTH OF BLOCK 33 AND BEING WEST OF SOUTH CENTER STREET AND EAST OF SOUTH DAVID STREET, PARK ADDITION TO THE TOWN OF CASPER, LOCATED IN THE SOUTHWEST QUARTER OF THE NORTHEAST QUARTER OF SECTION 9, TOWNSHIP 33 NORTH, RANGE 79 WEST OF THE SIXTH PRINCIPAL MERIDIAN, NATRONA COUNTY, WYOMING BEING DESCRIBED BY METES AND BOUNDS AS FOLLOWS:

BEGINNING AT THE SOUTHEAST CORNER OF SAID BLOCK 32 (REC. TACK AND DISC), THENCE SOUTH 0°04'28" EAST A DISTANCE OF 69.94 FEET ALONG THE WESTERLY RIGHT OF WAY OF SOUTH CENTER STREET TO THE NORTHEAST CORNER OF SAID BLOCK 33 (SET PK NAIL), THENCE SOUTH 89°56'29" WEST A DISTANCE OF 299.94 FEET ALONG THE NORTH LINE OF SAID BLOCK 33 TO THE NORTHWEST CORNER OF SAID BLOCK 33 (SET 'X' IN CONCRETE), THENCE NORTH 0°01'00" WEST A DISTANCE OF 70.00 FEET ALONG THE EASTERLY RIGHT OF WAY LINE OF SOUTH DAVID STREET TO THE SOUTHWEST CORNER OF SAID BLOCK 32 (REC. REBAR AND ALUMINUM CAP), THENCE NORTH 89°57'13" EAST A DISTANCE OF 299.87 FEET ALONG THE SOUTH LINE OF SAID BLOCK 32 TO THE POINT OF BEGINNING, CONTAINING 0.482 ACRES MORE OR LESS.

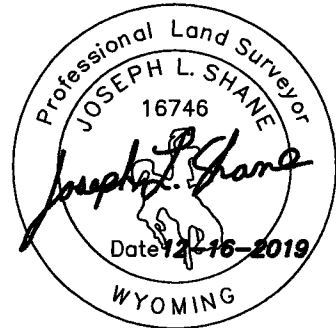

SURVEYOR'S CERTIFICATE:

I, JOSEPH L. SHANE, A REGISTERED LAND SURVEYOR IN THE STATE OF WYOMING, DO HEREBY CERTIFY THAT THIS PLAT WAS MADE FROM NOTES TAKEN DURING AN ACTUAL SURVEY MADE BY ME IN THE MONTH OF SEPTEMBER, 2019 AND THAT THIS PLAT IS AN ACCURATE REPRESENTATION THEREOF.

SHANE SURVEYING

Prepared by Shane Surveying
 P.O. Box 51412
 Casper, WY 82605
 PH: (307)251-7488

PLAT FOR STREET VACATION
 LOCATED BETWEEN BLOCKS 32 & 33 AND BETWEEN S. CENTER ST.
 AND S. DAVID ST., PARK ADDITION TO THE TOWN OF CASPER,
 SW1/4NE1/4, SEC. 9, T.33N., R.79W.,
 6th P.M., NATRONA COUNTY, WYOMING

Drawn By: JLS
Checked By: JLS
Date: 11/18/2019
Rev. Date: NONE
Job No.: 33-19
SHEET: PLAT FOR STREET VACATION

VACATION EXHIBIT

W. 8th Street from S. David Street to S. Center Street
 Located in Section 9, T.33N., R.79W., 6th P.M.
 City of Casper, Natrona County, Wyoming

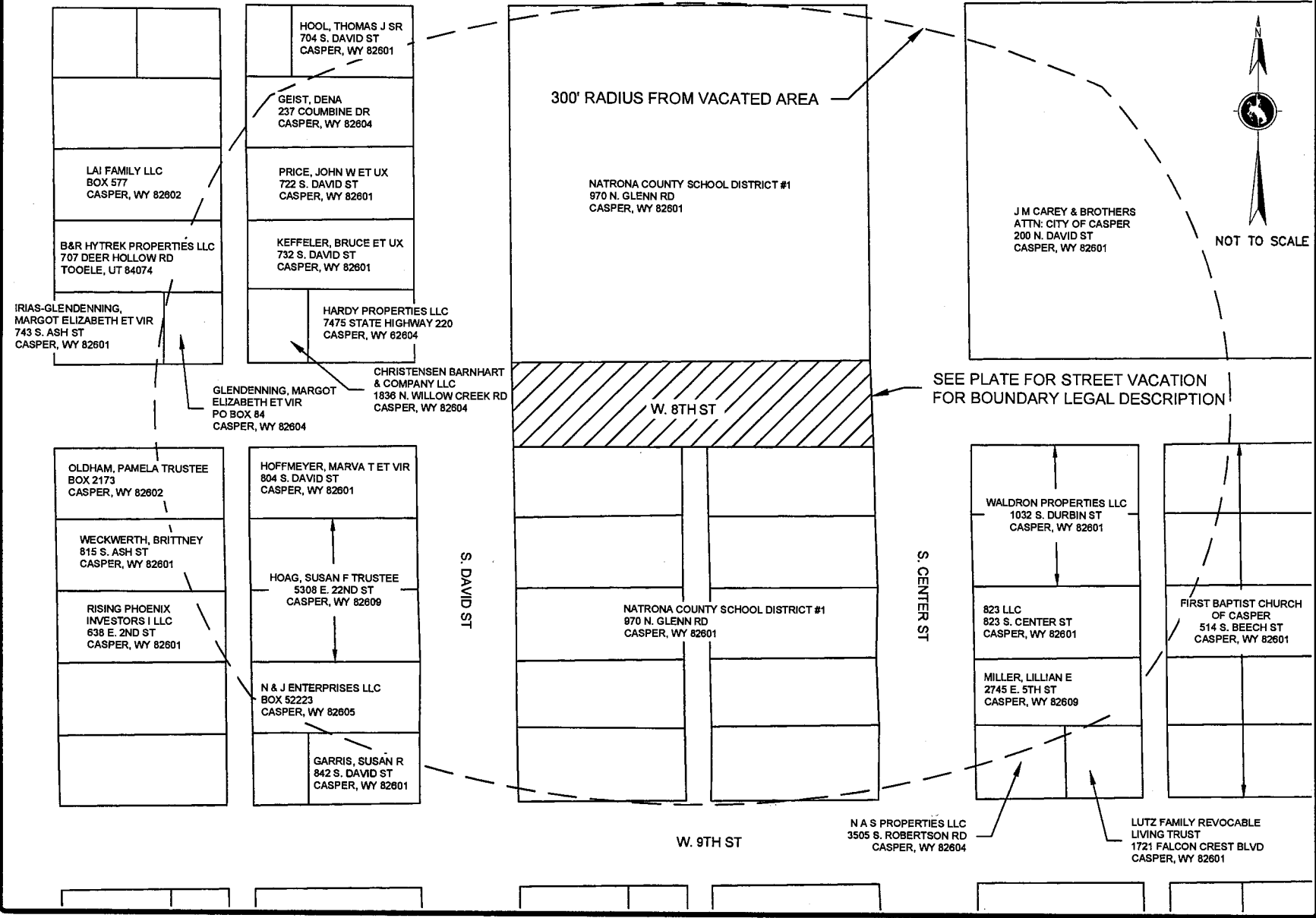
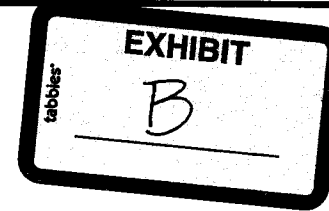

Prepared For:
CITY OF CASPER
 200 N. David
 Casper, WY • 82601 • 307.235.8400

Prepared By:
ECS ENGINEERS
 111 West 2nd Street, Suite 600
 Casper, WY 82601 • 307.337.2883

Date Drawn: 12.12.2019
 Project No. 190009

Scale: SEE DRAWING
 File Name: Ownership Exhibit.dwg

PAGE 1/1

ORDINANCE NO.15-20

AN ORDINANCE APPROVING THE VACATION OF WEST
8TH STREET, FROM SOUTH DAVID STREET TO SOUTH
CENTER STREET

WHEREAS, the Natrona County School District has requested the vacation of West 8th Street between South David and South Center Streets; and,

WHEREAS, the portion of West 8th Street proposed for vacation is located between Park School on the south, and the School District's bus hub on the north; and,

WHEREAS, the vacation of the street will improve pedestrian/student safety around the surrounding school facilities; and,

WHEREAS, a petition containing the signatures of a majority of the owners who own a majority of the property abutting the segments of the street proposed to be vacated and extending 300 feet in all directions from the street to be vacated has been submitted to the City as provided by W.S. §15-4-305; and,

WHEREAS, Natrona County School District has submitted signed consents to release and abandon the utility easement associated with said portion of West 8th Street being proposed for vacation, from all of Casper's utility companies; and,

WHEREAS, the City of Casper has determined that said portion of West 8th Street can be vacated without adversely impacting utility services and traffic circulation within the area; and,

WHEREAS, it is the desire of the governing body of the City of Casper to approve said vacation of a portion of West 8th Street as public right-of-way.

NOW, THEREFORE, BE IT ORDAINED BY THE GOVERNING BODY OF THE CITY OF CASPER, WYOMING:

SECTION 1:

That the vacation of West 8th Street, between South David and South Center Streets, as set forth in Exhibits "A" and "B", which by reference herein are made a part of this ordinance, is hereby approved.

SECTION 2:

That the vacated street shall revert to the adjoining land owners, as provided by law.

SECTION 3:

This ordinance shall be in full force and effect from and after passage on three readings, publication pursuant to law.

PASSED on 1st reading the _____ day of _____, 2020.

PASSED on 2nd reading the _____ day of _____, 2020.

PASSED, APPROVED, AND ADOPTED on 3rd and final reading the ____ day of _____, 2020.

APPROVED AS TO FORM:



ATTEST:

CITY OF CASPER, WYOMING
A Municipal Corporation

Fleur Tremel
City Clerk

Steven K. Freel
Mayor

June 22, 2020

MEMO TO: J. Carter Napier, City Manager *JCN*

FROM: Andrew Beamer, Public Services Director *AB*
Cynthia Langston, Solid Waste Manager

SUBJECT: Adopting Revisions to the Current Rate Resolution for Residential and Commercial Solid Waste Collection, Recycling, and Disposal at the Casper Solid Waste Facility.

Meeting Type & Date
Regular Council Meeting
July 7, 2020

Action Type
Resolution

Recommendation
That Council, by resolution, adopt revisions to the current residential and commercial solid waste collection, recycling, and disposal fees at the Casper Solid Waste Facility, to become effective September 1, 2020 and rescind Resolution No. 19-250.

Summary
City Council approved staff to proceed with opening the recycling depots and directed staff to provide a rate resolution to increase the residential refuse collection rate by \$1.70 per month. One thousand four hundred and eighty (1,480) online surveys, 142 phone-in surveys, and 124 mail-in surveys, for a total of 1,746 were received from local residents. Five options were presented to the community. The overwhelming choice (over 60%) was option 3, which is keep the depots, open the Material Recovery Facility (MRF), and increase the residential refuse collection rate by \$1.70 per month.

City Council has directed staff to pursue negotiating an agreement with the towns of Bar Nunn, Evansville and Mills for the City of Casper to charge for services to collect, decontaminate, bale and broker the recyclable materials deposited from their community recycling depots. If the towns agree to pay for these services, the total residential refuse collection rate increase could be reduced by as much as \$0.18 per month. Rates will be evaluated in November 2020 to determine if adjustments are needed.

Staff recommends approving these rate increases effective September 1, 2020 to provide time to negotiate service agreements with the surrounding towns and to hire staff to operate the MRF.

In addition to increasing the residential refuse collection rate by \$1.70 per month (or less depending on the surrounding town service agreements), staff recommends a commercial recyclable rate of \$35 per ton. The commercial recyclable rate would be charged to haulers other than City recycling haulers who bring recyclable materials to the MRF, such as Glenrock, Douglas, or Rawlins haulers.

Financial Consideration

Staff recommends these fees become effective on September 1, 2020.

Oversight/Project Responsibility

Cynthia Langston, Solid Waste Manager

Attachments

Resolution

APPENDIX A

RESOLUTION NO. 20-137

A RESOLUTION ESTABLISHING RATES FOR RESIDENTIAL AND COMMERCIAL SOLID WASTE COLLECTION, RECYCLING AND DISPOSAL AT THE CASPER REGIONAL SOLID WASTE FACILITY, AND RESCINDING RESOLUTION NO. 18-70 19-250.

NOW, THEREFORE, BE IT RESOLVED BY THE GOVERNING BODY OF THE CITY OF CASPER, WYOMING: That the following rates are hereby established for the collection, recycling and disposal of garbage, recyclables and refuse effective January 1, 2020, except where noted otherwise.

A. RESIDENTIAL SOLID WASTE COLLECTION SERVICES

1. Single-Family Resident and Multi-Family

- a. Garbage Collection \$17.10 \$18.80 Monthly (Per Unit Charge)
Effective September 1, 2020
- \$17.27 \$19.00* Monthly (Per Unit Charge)
Effective January 1, 2021

\$8.55 Monthly (Per Unit Charge)
50% (A.I. a.)
Effective January 1, 2020

*Note: 1% rate increase approved 12/17/2019 by Council to be in effect 1/1/21; will be re-evaluated in November 2020.

- b. Additional 90-gallon \$8.64 Monthly (Per Unit Charge)
50% (A.I. a.)
Effective January 1, 2021

- 2. Additional Requested Pickup Services \$14.00 Per 90 Gallon Container

\$42.00 Per 300 Gallon Container

3. Extra Collection

- a. Three Large Items Included in A.I.
- b. Each Additional Minute of Collection \$12.00

4. Special Collection \$60.00 Minimum Charge

- a. First Five Minutes Included
- b. Each Additional Minute of Collection \$12.00

B. COMMERCIAL SOLID WASTE COLLECTION SERVICES

1. Commercial Collection Tables*

Effective January 1, 2020

Number of Trash Pickup Services Per Week*	1 Yard Bin Monthly Charges	2 Yard Bin Monthly Charges	3.Yard Bin Monthly Charges	4 Yard Bin Monthly Charges	6 Yard Bin Monthly Charges	8 Yard Bin Monthly Charges	90 Gallon Bin Monthly Charges	200 Gallon Bin Monthly Charges	300 Gallon Bin Monthly Charges	400 Gallon Bin Monthly Charges
One Pickup Per Week	\$58	\$77	\$95	\$116	\$157	\$204	\$19	\$37	\$58	\$77

If commercial customer provides trash container, a 7% reduction is applied to the rate.

*NOTE: The monthly charges are linear for number of trash pickup services per week; therefore, charges for multiple pickups are multiplied by the monthly charges indicated in the above table for each size of container, i.e. two (2) pickups per week for a 4 Yard Bin would be $\$116 \times 2 = \232 .

Effective January 1, 2021

Number of Trash Pickup Services Per Week*	1 Yard Bin Monthly Charges	2 Yard Bin Monthly Charges	3 Yard Bin Monthly Charges	4 Yard Bin Monthly Charges	6 Yard Bin Monthly Charges	8 Yard Bin Monthly Charges	90 Gallon Bin Monthly Charges	200 Gallon Bin Monthly Charges	300 Gallon Bin Monthly Charges	400 Gallon Bin Monthly Charges
One	\$59	\$78	\$96	\$117	\$159	\$206	\$19	\$37	\$659	\$78

If commercial customer provides trash container, a 7% reduction is applied to the rate.

Commercial Collection Tables*

- 2. Special Collection \$60.00 Minimum Charge Included
 - a. First Five Minutes Included
 - b. Each Additional Minute of Collection \$12.00

(INTENTIONALLY LEFT BLANK)

3. Additional Requested Collection (must provide request for additional collection one day prior to requested date)

See Following Table

Effective January 1, 2020

Bin Size	Delivery and Removal	One Normal MSW Dump	Construction Waste (Heavy or Dense)
2 Cubic Yard	\$35	\$55	\$71
3 Cubic Yard	\$35	\$55	\$83
4 Cubic Yard	\$35	\$68	\$95
6 Cubic Yard	\$35	\$74	\$118
8 Cubic Yard	\$35	\$95	\$129

Effective January 1, 2021

Bin Size	Delivery and Removal	One Normal MSW Dump	Construction Waste (Heavy or Dense)
2 Cubic Yard	\$35	\$56	\$71
3 Cubic Yard	\$35	\$56	\$83
4 Cubic Yard	\$35	\$69	\$95
6 Cubic Yard	\$35	\$75	\$118
8 Cubic Yard	\$35	\$96	\$129

4. Commercial "On Call" Metal Bin See A.5.a., Residential "On Call" Metal Bin
5. Overfilled Bins \$12.00 Per Yard
6. Commercial Penalty Fees \$17.70
- a. Habitual Customer Call Backs Double Fees
- b. Extremely Dense or heavy Waste*
*concrete, dirt, sand, sludge or garbage contents weighing more than 500 pounds
7. Roll Off Container Services \$90.00
- a. Delivery Fee \$231.00 Per Service
- b. Collection (Only) Service Fee Rate X Tonnage
- c. Disposal \$3.00 Per Day or \$21 Per
- d. Container Rental (per day)

	Week
e. Pre-Service Payment (delivery and one collection fee)	\$321 Prior to delivery
8. Customers Outside the City Limits Within a Two-Mile Perimeter	Apply 1.30% Multiplier to Solid Waste Commercial Collection Fees Found in Table B.1

C. COMMERCIAL COLLECTION RECYCLING SERVICES

1. Commercial recycling service charges for City and non-City sanitation customers are determined by applying a multiplier to change the solid waste rate schedule fees found in B.1.

OCC - Old Corrugated Containers (Cardboard)	0.50 OR 50%
OWP-Old White Paper or Office Pack	0.50OR50%
UBC - Used Aluminum Beverage Cans	Free Collection

(INTENTIONALLY LEFT BLANK)

D. DISPOSAL CHARGES AT CASPER REGIONAL SOLID WASTE FACILITY

I. Municipal Solid Waste (MSW) Disposal Charges for residents of Natrona County. See Table Below. NOTE: An additional 30% fee will be assessed for individuals residing outside of Natrona County, with the exception of those individuals residing within jurisdictions having written agreements with the City of Casper.

a.

	Natrona County Residents and Other Residents Residing Within Jurisdictions Having Written Agreements with the City of Casper	Outside-Natrona County Residents
Residential Garbage	\$51.00 Per Ton	\$66.30 Per Ton
Residential Garbage	\$53.00 Per Ton (Eff. 1/1/21)	\$68.90 Per Ton (Eff. 1/1/21)
Automobile	\$6.00 Per Automobile	\$7.80 Per Automobile
10-Foot or Less Pickup Bed Quantity	\$18.00 Per Bed	\$23.40 Per Bed
RESIDENTIAL RECYCLABLES (Corrugated Cardboard, Paperboard, Aluminum, Tin cans, Newspaper, Magazines, White Office Paper, Plastics #1, and Plastics #2.	NO CHARGE	NO CHARGE
Chlorofluorocarbon (CFC) Containing Appliances	\$32.00 Per Item (If Doors on Appliance)	\$41.00 Per Item (If Doors on Appliance)
	\$28.00 Per Item (If Doors Removed From Appliance)	\$36.40 Per Item (If Doors Removed From Appliance)
Passenger Cars and Pickup Tires	\$3.00 Per De-Rimmed Tire (Limit 30)	\$3.90 Per De-Rimmed Tire (Limit 30)
Heavy Truck Tires or Semi Tires	\$6.00 Per De-Rimmed Tire (Limit 30)	\$7.80 Per De-Rimmed Tire (Limit 30)

Bulk Car, Pickup Truck, Heavy Truck, or Semi Tires (More than 30 de-rimmed tires)	\$135.00 Per Ton	\$175.50 Per Ton
---	------------------	------------------

Electronics	No Charge	No Charge
-------------	-----------	-----------

Fluorescent Bulbs	No Charge	No Charge
-------------------	-----------	-----------

b. Residential Garbage Exceptions

Water Bill Punch Pass	Included in Monthly Rate	<i>N/A</i>
-----------------------	--------------------------	------------

Household Hazardous Waste	No Charge	No Charge
---------------------------	-----------	-----------

Clean Yard or Green Waste	No Charge	No Charge
---------------------------	-----------	-----------

Clean Metals or Appliances	No Charge (Non CFC)	No Charge (Non CFC)
----------------------------	---------------------	---------------------

The City Manager or his/her designee shall impose a fee of \$15.00 per load, in addition to any other charges otherwise due the City by residential customers transporting unsecured loads, as defined in Sections 8.40.100(a) and 8.32.140(±) of the Casper Municipal Code, to the solid waste facility. Upon payment of the additional \$15.00 fee for unsecured loads, the City may, based upon available supplies, provide such user a tarp, mess cord, or other device to prevent material from blowing or otherwise falling out of any such vehicle.

c.

	Natrona County	Outside-Natrona County Businesses
Commercial Municipal Solid Waste Garbage	\$51.00 Per Ton	\$66.30 Per Ton
Commercial Municipal Solid Waste Garbage	\$53.00 Per Ton (Effective 1/1/21)	\$68.90 Per Ton (Effective 1/1/21)
8-Foot Pickup Bed Quantity	\$18.00 Per Bed	\$23.40 Per Bed

COMMERCIAL RECYCLABLES (Corrugated Cardboard, Paperboard, Aluminum, Tin cans, Newspaper, Magazines, White Office Paper, Plastics #1, and Plastics #2	\$35 PER TON	\$35 PER TON
Chlorofluorocarbon (CFC) Containing Appliances	\$32.00 Per Item (If Doors on Appliance)	\$41.00 Per Item (If Doors on Appliance)
	\$28.00 Per Item (If Doors Removed From Appliance)	\$36.40 Per Item (If Doors Removed From Appliance)
De-Rimmed Passenger Cars and Pick-up Tires	\$3.00 Per Tire (Limit 30)	\$3.90 Per Tire (Limit 30)
De-Rimmed Heavy Truck Tires or Semi Tires	\$6.00 Per Tire (Limit 30)	\$7.80 Per Tire (Limit 30)
Bulk De-Rimmed Tires (Car, Pickup truck, Heavy Truck and Semi Tires)	\$135.00 Per Ton	\$175.50 Per Ton
Tires Larger Than 10 Inches in Width and 22 Inches in Diameter	Rates will cover actual disposal costs. Disposal costs vary with market pricing. Current rate sheets will be available upon request.	
Electronics	\$0.40 Per Pound	\$.52 Per Pound
Fluorescent Light Bulbs	\$1.00 Per Bulb	\$1.30 Per Bulb
d. Commercial Garbage Exceptions		
Clean Yard or Green Waste Other Than Grass (Check-in at Scale House)	No Charge	No Charge
Clean Yard or Green	\$70.00 per Week	\$91.00 per Week

Waste (Check-in at
Dawn to Dusk
Compost Yard)

Grass (Check-in at Scale House) July 1 thru October 31	\$18.00 Per Truck Load	\$ 23.40 Per Truck Load
Clean Metals or Appliances	No Charge (Non CFC)	No Charge (Non CFC)

The City Manager or his/her designee shall impose a fee of \$50.00 per load, in addition to any other charges otherwise due the City by commercial customers transporting unsecured loads, as defined in Sections 8.40.100(a) and 8.32.140(t) of the Casper Municipal Code, to the solid waste facility.

2. Other Solid Waste

- a. Minimum Charge- Unless Specified \$63.00 Per Ton
- b. Waste Used as Alternate Daily Cover \$33.00 Per Ton (ADC) or Clean Untreated Wood
- c. Petroleum Contaminated Soils with TPH DRO/GRO 8015 Test Results \$63.00 Per Ton*
*After 300 tons disposed per project a reduced rate of \$37.00 may apply.

0-10,000 PPM TPH	No Lab Surcharge
10,000-15,000 PPM TPH	\$250.00 Lab Surcharge, Plus Any Required Additional Laboratory or Disposal Costs Over the Surcharge
15,000- PPM TPH	\$500.00 Lab Surcharge, Plus Any Required Additional Laboratory or Disposal Costs Over the Surcharge

NOTE: Laboratory Work Must Be from a Local EPA-Certified Laboratory
- d. Friable Asbestos or Other Waste Requiring Special Handling \$85.00 Per Ton*
*After one ton disposed per project a reduced rate of \$63.00 may apply.
- e. Trailers or Mobile Homes Too Large for Scale \$1,500 Minimum Additional Special Handling or Cell Development Fee May Apply

- f. Inert Wastes (Construction and Demolition Waste that cannot Be baled) \$33 Per Ton
- g. Mixed Wastes \$102 Per Ton
- h. Wind Turbine Blades* and Motor Housing \$75 Per Ton
*Special Handling Fee \$90 Per Blade

E. CONDITIONALLY EXEMPT SMALL QUANTITY GENERATOR (CESQG) HAZARDOUS WASTE

Rates will cover actual disposal costs. Disposal costs vary with market pricing and a current rate sheet will be available at the City's solid waste facility.

F. COMMUNITY CLEANUP PROGRAM Fees Waived

Certificates may be issued by the Solid Waste Division in cooperation with the Keep Casper Beautiful.

G. NON PROFIT THRIFT STORES

B.7. Fees Apply, with
B.7.c. Ldf Disposal Fees Waived and
B.7.d Rental Fees Waived
D.I.c. Fees Apply, with
Electronic Fees Waived

(INTENTIONALLY LEFT BLANK)

H. COMPOST YARD PRODUCTS

Compost Yard Product	Description	Retail Price Per Cubic Yard or Per 5-gal	Wholesale Price Per Cubic Yard*
4" Natural Mulch	Single Ground Tree Branches or Clean Wood	\$12.50	\$8.50
4" Natural Mulch 5 Gallons	Single Ground Tree Branches or Clean Wood in reusable 5-gallon bucket.	\$0.35	Not Available
2" Natural Mulch	Double Ground Tree Branches or Clean Wood	\$16.50	\$12.50
2" Natural Mulch 5 Gallons	Double Ground Tree Branches or Clean Wood in reusable 5-gallon bucket.	\$0.50	Not Available
Natural Fine Mulch	Wood Fines from screened double ground tree branches or clean wood	\$9.00	\$6.00
Natural Fine Mulch 5 Gallons	Wood Fines from screened double ground tree branches or clean wood in a reusable 5-gallon bucket.	\$0.75	Not Available
Colored Mulch	Double Ground Tree Branches or Clean Wood that has been Dyed Red, Black, Gold, Brown or other color.	\$35.00***	\$30.00***
Colored Mulch 5 Gallons	Double Ground Tree Branches or Clean Wood that has been Dyed Red, Black, Gold, Brown or other color in reusable 5-gallon bucket.	\$1.00	Not Available
Compost	Composted Yard Waste	\$20.00	\$18.00
Compost 5 Gallons	Composted Yard Waste in reusable 5-gallon bucket.	\$1.00	Not Available
Screened Top Soil	Sod dirt or top soil that has been through a ½" screen.	\$25.00	Not Available
Amended Top Soil	A combination of top soil, sand, fine mulch and compost	\$35.00	Not Available
Wood Pallet AND SAND		FREE	FREE
5-gallon Bucket	A 5-gallon bucket with no lid to carry product	\$4.00 each**	Not Available
Loading	Loading of material to customer vehicle.	\$10 per load	Not Available
Loading with Yard Waste Incentive Voucher	Loading of material to customer vehicle if the customer is utilizing yard waste incentive vouchers for free Product.	\$15.00 per load	Not Available

*Commercial company pre-ordered purchases only.

**Price for 5-gallon bucket may vary with market costs.

***Price may vary with current market costs to purchase the colorizer.

I. COMPOST YARD PRODUCTS -- PROMOTIONAL SALES EVENTS

Promotional sales events and pricing may occur seasonally with wholesale pricing and free loading.

J. COMMERCIAL EVENTS AND ACCIDENT SCENE STREET SWEEPING SERVICES

Commercial events and accident scene street sweeping services for special business events and accident scenes with responsible parties are determined by applying an hourly rate to the time to perform the service. An hourly rate of \$170 per hour is assessed Monday through Friday from 7 a.m. to 3 p.m. (normal operational hours) and an hourly rate of \$180 per hour is assessed during non-normal operational hours.

K. RESIDENTIAL YARD WASTE INCENTIVE PROGRAM

Natrona County residents may receive a voucher with a specific dollar value to use towards the purchase of compost or natural (non-colored) wood chips when they bring their yard waste to the compost yard. Only grass, leaves, twigs, and branches are eligible. One half (1/2) of a Pickup Truck Bed (a few bags or branches) equals \$2.00 voucher. A level Pickup Truck Bed equals a \$5.00 voucher. A Heaping Pickup Truck Bed equals a \$10.00 voucher. Vouchers cannot be exchanged for currency, they are not transferrable, and all vouchers expire one year from the issue date. Loading Fee with this program is \$15 per Load.

BE IT FURTHER RESOLVED: That Resolution No. 19-250 **18-70** pertaining to fees for the collection, disposal or recycling of solid waste is hereby rescinded.

PASSED, APPROVED, AND ADOPTED this _____ day of _____, 2020.

APPROVED AS TO FORM:
(Solid Waste Rates 2020/2021)

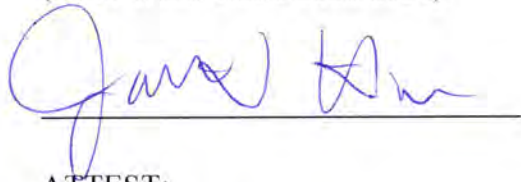

ATTEST:

CITY OF CASPER, WYOMING
A Municipal Corporation:

Fleur Tremel
City Clerk

Steven K. Freel
Mayor

June 22, 2020

MEMO TO: J. Carter Napier, City Manager 

FROM: Tim Cortez, Parks and Recreation Director
Randy Norvelle, Parks Manager

SUBJECT: Authorizing a Sole Source Contract for Professional Services with Granite Peak Pump Service, Inc., in the amount not to exceed \$107,945.00 for the purchase and installation of a Watertronics Pump Station.

Meeting Type & Date

Regular Council Meeting
July 7th, 2020

Action type

Resolution

Recommendation

That Council, by resolution, authorize a Sole Source Contract for Professional Services with Granite Peak Pump Station, Inc., in the amount not to exceed \$107,945.00, for Watertronics Pump Station for the Casper Municipal Golf Course.

Summary

The current pump station used for irrigating the Links 9-hole golf course and practice range was installed in 1995 and has exhausted its useful life. The Parks and Recreation Department is requesting a sole source purchase with Granite Peak Pump Service, Inc., for a Watertronics Pump Station which communicates with the existing Toro National Support Network and provides exclusive features that helps protect the ageing irrigation system on the Links Golf Course.

Financial Considerations

Watertronics Pump Station	\$107,945
Pump Station Building Upgrades	<u>\$ 17,055</u>
Total Project Budget	\$125,000

Funding source is One Cent #16 as entered in FY21 Capital Budget.

Oversight/Project Responsibility

Randy Norvelle, Parks Manager
Jason Ostlund, Golf Course Superintendent

Attachments

Resolution
Professional Services Contract
Exhibit A

CONTRACT FOR PROFESSIONAL SERVICES

PART I - AGREEMENT

This Contract for Professional Services ("Contract") is entered into on this 7th day of July, 2020, by and between the following parties:

1. The City of Casper, Wyoming, a Wyoming municipal corporation, 200 North David Street, Casper, Wyoming 82601 ("City").
2. Granite Peak Pump Service, Inc. 919 Betsy Drive, Billings, Montana 59105 ("Contractor").

Throughout this document, the City and the Contractor may be collectively referred to as the "parties."

RECITALS

A. The City is undertaking a project to replace the pump station for the Links Course at the Casper Municipal Golf Course.

B. The project requires professional services for the purchase and installation of a Watertronics Pump Station, to replace the existing one which failed at the Casper Municipal Golf Course.

C. The Contractor represents that it is ready, willing, and able to provide the professional services to City as required by this Contract.

D. The City desires to retain a Contractor for the sole source purchase and installation of such services.

NOW, THEREFORE, in consideration of the covenants and conditions set forth herein to be performed, the parties agree as follows:

1. SCOPE OF SERVICES:

The City and Contractor shall perform the services set forth on Exhibit A to this Contract, which is hereby made a part of this Contract.

2. TIME OF PERFORMANCE:

The services of the Contractor shall be undertaken and completed on or before the 30th day of August, 2020.

3. COMPENSATION:

In consideration of the performance of services rendered under this Contract, the Contractor shall be compensated for services performed in accordance with paragraph 1, not to exceed a lump sum of One Hundred Seven Thousand Nine Hundred Forty-Five Dollars and 00/100 (\$107,945.00).

4. METHOD OF PAYMENT:

Payment will be made following completion of the terms set forth herein and receipt of an itemized invoice, certified under penalty of perjury, from the Contractor for services rendered in conformance with the Contract, and following approval by the Casper City Council. The invoice for payment must specify the correct amount due; that the Contractor has performed the services rendered under this Contract, in conformance with the Contract, and that it is entitled to receive the amount requested under the terms of the Contract.

If amounts owed by the Contractor to the City for any goods, services, licenses, permits or any other items or purpose remain unpaid beyond the City's general credit policy, those amounts may be deducted from the payment being made by the City to the Contractor pursuant to this Contract.

5. TERMS AND CONDITIONS:

This Contract is subject to and incorporates the provisions attached hereto as PART II -- GENERAL TERMS AND CONDITIONS.

6. EXTENT OF CONTRACT:

This Contract represents the entire and integrated Agreement between the City and the Contractor, and supersedes all prior negotiations, representations, or agreements, either written or oral. The Contract may be amended only by written instrument signed by both the City's and the Contractor's authorized representatives.

The City and the Contractor each individually represent that they have the requisite authority to execute this Contract and perform the services described in this Contract.

7. TITLE AND RISK OF LOSS

Title passes to the City upon delivery of the items set forth on Exhibit A to the Casper Municipal Golf Course located at 2120 Allendale Avenue, Casper, Wyoming. Contractor bears all risk of loss or damage until delivery.

IN WITNESS WHEREOF, the undersigned duly authorized representatives of the parties have executed this Contract as of the day and year above.

APPROVED AS TO FORM

Walter Trout

ATTEST

CITY OF CASPER, WYOMING
A Municipal Corporation

Fleur Tremel
City Clerk

Steve K. Freel
Mayor

WITNESS

CONTRACTOR
Granite Peak Pump Station, Inc.

By: _____

By: _____

Printed Name: _____

Printed Name: _____

Title: _____

Title: _____

IN WITNESS WHEREOF, the undersigned duly authorized representatives of the parties have executed this Contract as of the day and year above.

APPROVED AS TO FORM

ATTEST

CITY OF CASPER, WYOMING
A Municipal Corporation

Fleur Tremel
City Clerk

Steve K. Freel
Mayor

WITNESS

CONTRACTOR
Granite Peak Pump Station, Inc.

By: _____

By: Jay E. Glen

Printed Name: _____

Printed Name: Jay E. Glen

Title: _____

Title: President

CONTRACT FOR PROFESSIONAL SERVICES

PART II - GENERAL TERMS AND CONDITIONS

1. TERMINATION OF CONTRACT:

1.1 The City may terminate this Contract anytime by providing thirty (30) days written notice to Contractor of intent to terminate said Contract. In such event, all finished or unfinished documents, data, studies and reports prepared by the Contractor under this Contract shall, at the option of the City, become its property, and the Contractor shall be entitled to receive just and equitable compensation for any satisfactory work completed on such documents.

1.2 Notwithstanding the above, the Contractor shall not be relieved of liability to the City for damages sustained by the City, by virtue of termination of the Contract by Contractor, or any breach of the Contract by the Contractor, and the City may withhold any payments to the Contractor for the purpose of setoff until such time as the exact amount of damages due the City from the Contractor are determined.

2. CHANGES:

The City may, from time to time, request changes in the scope of the services of the Contract. Such changes, including any increase or decrease in the amount of the Contractor's compensation, which are mutually agreed upon between the City and the Contractor, shall be incorporated in written amendments to this Contract. There shall be no increase in the amount of Contractor's compensation unless approved by Resolution adopted by City.

3. ASSIGNABILITY:

The Contractor shall not assign any interest in this Contract, and shall not transfer any interest in the same (whether by assignment or novation) without the prior written approval of the City: provided, however, that claims for money due or to become due the Contractor from the City under this Contract may be assigned to a bank, trust company, or other financial institution, or to a trustee in bankruptcy, without such approval. Notice of any assignment or transfer shall be furnished to the City within five (5) business days of any assignment or transfer.

4. AUDIT:

The City or any of its duly authorized representatives shall have access to any books, documents, papers, and records of the Contractor which are directly pertinent to the Contract for the purpose of making audit, examination, excerpts, and transactions.

5. EQUAL EMPLOYMENT OPPORTUNITY:

In carrying out the program, the Contractor shall not discriminate against any employee or applicant for employment because of race, color, religion, sex, national origin, or disability. The Contractor shall take affirmative action to ensure that applicants for employment are employed, and that employees are treated during employment, without regard to their race, color, religion, sex, national origin, or disability. Such action shall include, but not be limited to, the following: employment upgrading, demotion, or transfer; recruitment or recruitment advertising; layoff or termination; rates of pay or other forms of compensation; and selection for training, including apprenticeship. The Contractor shall post in conspicuous places, available to employees and applicants for employment, notices required by the government setting forth the provisions of this nondiscrimination clause. The Contractor shall state that all qualified applicants will receive consideration for employment without regard to race, color, religion, sex, national origin, or disability.

6. OWNER OF PROJECT MATERIALS:

All finished or unfinished documents, data, studies, surveys, drawings, maps, models, photographs, films, duplicating plates, and reports prepared by the Contractor under this Contract shall be considered the property of the City, and upon completion of the services to be performed, they will be turned over to the City provided that, in any case, the Contractor may, at no additional expense to the City, make and retain such additional copies thereof as Contractor desires for its own use; and provided further, that in no event may any of the documents, data, studies, surveys, drawings, maps, models, photographs, films, duplicating plates, or other reports retained by the Contractor be released to any person, agency, corporation, or organization without the written consent of the City.

7. FINDINGS CONFIDENTIAL:

All reports, information, data, etc., given to or prepared, or assembled by the Contractor under this Contract are confidential and shall not be made available to any individual or organization by the Contractor without the prior written consent of the City.

8. GOVERNING LAW:

This Contract shall be governed by the laws of the State of Wyoming. The Contractor shall also comply with all applicable laws, ordinances, and codes of the local, state, or federal governments and shall not trespass on any public or private property in performing any of the work embraced by this Contract.

9. PERSONNEL:

The Contractor represents that it has, or will secure, all personnel required in performing the services under this Contract. Such personnel shall not be employees of the City. All of the services required shall be performed by the Contractor, or under its supervision, and all personnel engaged in the work shall be fully qualified. All personnel employed by Contractor shall be employed in conformity with applicable local, state or federal laws.

10. SUBCONTRACTOR:

The Contractor shall not employ any subcontractor to perform any services in the scope of this project, unless the subcontractor is approved in writing by the City. Any approved subcontractor shall be paid by the Contractor.

11. INSURANCE AND INDEMNIFICATION:

A. **Prior to** the commencement of work, Contractor shall procure and maintain for the duration of the contract insurance against claims for injuries to persons or damages to property which may arise from or in connection with the performance of the work hereunder by the Contractor, its subcontractors, agents, representatives, or employees.

B. *Minimum Scope and limit of Insurance.*

Coverage shall be at least as broad as:

1. Commercial General Liability (CGL): Insurance Services Office Form CG 00 01 covering CGL on an "occurrence" basis, including products and completed operations, property damage, bodily injury and personal & advertising injury with limits no less than the sum of Two Hundred Fifty Thousand Dollars (\$250,000) to any claimant for any number of claims arising out of a single transaction or occurrence; or the sum of Five Hundred Thousand Dollars (\$500,000) for all claims arising out of a single transaction or occurrence. If a general aggregate limit applies, the general aggregate limit shall apply separately to this project/location. The CGL policy shall be endorsed to contain Employers Liability/Stop Gap Coverage
2. Automobile Liability: Insurance Services Office Form Number CA 0001 covering, Code 1 (any auto), or if Contractor has no owned autos, Code 8 (hired) and 9 (non-owned), with limit no less than Five Hundred Thousand (\$500,000) per accident for bodily injury and property damage.
3. Workers' Compensation: as required by the State of Wyoming with Statutory Limits.

4. Professional Liability (Errors and Omissions) Insurance appropriate to the Contractor's profession, with limit no less than the sum of Two Hundred Fifty Thousand Dollars (\$250,000) to any claimant for any number of claims arising out of a single transaction or occurrence; or the sum of Five Hundred Thousand Dollars (\$500,000) for all claims arising out of a single transaction or occurrence. If a general aggregate limit applies, the general aggregate limit shall apply separately to this project/location.

C. *Higher Limits.* If the Contractor maintains higher limits than required under this Agreement, then the City shall be entitled to coverage for the higher limits maintained by the Contractor. Any available insurance proceeds in excess of the specified minimum limits of insurance and coverage shall be available to the City.

D. *Other Insurance Provisions*

The insurance policies are to contain, or be endorsed to contain, the following provisions:

1. *Additional Insured Status*

The City, its officers, elected and appointed officials, employees, agents and volunteers are to be covered as additional insureds on the CGL policy with respect to liability arising out of work or operations performed by or on behalf of the Contractor including materials, parts, or equipment furnished in connection with such work or operations. General liability coverage shall be provided in the form of an endorsement to the Contractor's insurance (at least as broad as ISO Form CG 20 10 11 85 or both CG 20 10 and CG 20 37 forms if later revisions used).

2. *Primary Coverage*

For any claims related to this contract, the Consultant's insurance coverage shall be primary and non-contributory insurance as respects the City, its officers, elected and appointed officials, employees, agents and volunteers.

3. *Notice of Cancellation*

Each insurance policy required above shall state that coverage shall not be canceled, materially changed, or reduced, except with notice to the City. Such notice to the City shall be provided in a commercially reasonable time.

4. *Waiver of Subrogation*

Contractor hereby grants to City a waiver of any right to subrogation which any insurer of said Contractor may acquire against the City by virtue of the payment of any loss under such insurance. Contractor agrees to obtain any endorsement that may be necessary to affect this waiver of subrogation, but this provision applies regardless of whether or not the City has received a waiver of subrogation endorsement from the insurer.

5. *Deductibles and Self-Insured Retentions*

Contractor has two options regarding deductibles and self-insured retentions:

- a. *Option 1:* Any deductibles or self-insured retentions must be declared to and approved by the City. Unless otherwise approved by the City in writing, any deductible may not exceed Ten Thousand Dollars (\$10,000). Unless otherwise approved in writing by the City, self-insured retentions may not exceed Ten Thousand Dollars (\$10,000), and the City may require the Contractor to provide proof of ability to pay losses and related investigations, claim administration, and defense expenses within the retention.
- b. *Option 2:* Contractor shall carry insurance with terms that require its insurance company to pay the full value of a covered claim from the first dollar of coverage, even if the Contractor is unable to pay any deductible or self-insured retention amount(s) required by the insurance policy. Contractor shall provide a written endorsement from its insurance carrier that such insurance coverage is in place, and shall keep such coverage in place during the term of this Contract and any subsequent time period required for claims made policies.

6. *Acceptability of Insurers*

Insurance is to be placed with insurers with a current A.M. Best's rating of no less than A:VII, unless otherwise agreed to in writing by the City.

7. *Claims Made Policies*

If any of the required policies provide coverage on a claims-made basis:

- a. The Retroactive Date must be shown and must be before the date of the contract or the beginning of contract work.
- b. Insurance must be maintained and evidence of insurance must be provided *for at least three (3) years after completion of the contract of work*. However, Contractor's liabilities under this Contract shall not be deemed limited in any way by the insurance coverage required.
- c. If coverage is canceled or non-renewed, and not *replaced with another claims-made policy form with a Retroactive Date* prior to the contract effective date, the Contractor must purchase "extended reporting" coverage for a minimum of *three (3) years* after completion of contract work and at all times thereafter until the applicable statute of limitations runs.

8. *Verification of Coverage*

Contractor shall furnish the City with original certificates and amendatory endorsements or copies of the applicable policy language effecting coverage required by this clause. All certificates and endorsements are to be received and approved by the City before work commences. However, failure to obtain the

required documents prior to the work beginning shall not waive the Contractor's obligation to provide them. The City reserves the right to require complete, certified copies of all required insurance policies, including endorsements required by these specifications, at any time.

9. *Subcontractors*

Contractor shall require and verify that all subcontractors maintain insurance meeting all the requirements stated herein, and Contractor shall ensure that the City is an additional insured on insurance required from subcontractors.

10. *Special Risks or Circumstances*

City reserves the right to reasonably modify these requirements, including limits, based on the nature of the risk, prior experience, insurer, coverage, or other special circumstances.

E. Contractor agrees to indemnify the City, the City's employees, elected officials, appointed officials, agents, and volunteers, and all additional insured and hold them harmless from all liability for damages to property or injury to or death to persons, including all reasonable costs, expenses, and attorney's fees incurred related thereto, to the extent arising from negligence, fault or willful and wanton conduct of the Contractor and any subcontractor thereof.

12. INTENT:

Contractor represents that it has read and agrees to the terms of this Contract and further agrees that it is the intent of the parties that Contractor shall perform all of the services for the compensation set forth in this Contract. Contractor also agrees that it is the specific intent of the parties, and a material condition of this Contract, that it shall not be entitled to compensation for other services rendered unless specifically authorized by the City by Resolution of its governing body. Contractor agrees that it has carefully examined the Scope of Services, and that the compensation is adequate for performance of this Contract.

13. WYOMING GOVERNMENTAL CLAIMS ACT:

The City does not waive any right or rights it may have pursuant to the Wyoming Governmental Claims Act, Wyoming Statutes Section 1-39-101 et seq., and the City specifically reserves the right to assert any and all rights, immunities, and defenses it may have pursuant to the Wyoming Governmental Claims Act.

14. NO THIRD PARTY BENEFICIARY RIGHTS:

The parties to this Contract do not intend to create in any other individual or entity the status of third-party beneficiary, and this Contract shall not be construed so as to create such status. The rights, duties and obligations contained in this Contract shall operate

only between the parties to this Contract, and shall inure solely to the benefit of the parties to this Contract. The parties to this Contract intend and expressly agree that only the parties signatory to this Contract shall have any legal or equitable right to seek to enforce this Contract, to seek any remedy arising out of a party's performance or failure to perform any term or condition of this Contract, or to bring an action for the breach of this Contract.

EXHIBIT A

Granite Peak Pump Service 919
Betsy Dr.
Billings, MT 59105
406-254-9972 Office
406-698-6313 Mobile
406-254-9533 Fax

Granite Peak Pump Service, Inc. CUSTOM

WATERTRONICS PUMP SYSTEM QUOTATION

Project Name:	Casper Municipal Links 9	Date:	6/15/20
Site Location:	Casper, WY	Quotation:	Q20033R3
Installation:	Inside - Weather Resistant Building	Quoted By:	Jay Glen
Customer Contact Name:	Randy Norvelle, Jason Ostlund Company: City of	Sales Rep:	
Casper, Municipal Golf Course		Phone:	Jay Glen
Address:		Email:	406-254-9972
City/State:	Casper, WY		jay@granitepeakpumpservice.com
Phone:	307-262-5477		
Email:	rnorvelle@casperwy.gov		
Performance:	950GPM @ 135PSI	Wetwell Depth:	14Ft. - 0in.
Input Power:	460VAC/3Phase/60Hz	Panel SCCR:	35KA
Model Number:	VTV-50X2/5ST-460-3-950-135	FCC Type:	B

CATEGORY	DESCRIPTION	QTY
Station Configuration	• Vertical Turbine - Station Spec	1
Approvals and Certifications	• UL Listed - Industrial Control Panel	1
	• FCC Part #15 Subpart B - Radio Frequency Devices	1
Paint Colors	• Paint Color - Watertronics - Sandstone	1
Pump Motors - Submersible	• 5HP Submersible Motor - 380-460V/3ph	1
Pump Motors - VHS	• 50HP VHS Premium Efficiency Motor - 460V/3Ph	2
Pumps - Submersible Turbine	• Pump, Submersible Turbine, 5HP	1
Pumps - Vertical Turbine	• Pump, Vertical Turbine, Integrity, 50HP, 1800RPM	2
Pump Discharge Heads	• Discharge Head - 6" Ductile Iron	2
Pump Columns	• Pressure Maint Pump Column - 2" Dia - Carbon Steel	1
	• VT Pump Column - 6" Dia, 12Ft Max Depth, Carbon STL	2
	• Mechanical Shaft Seal	2
Pump Seals	• Discharge Manifold - Duplex Pump	1
Discharge Manifolds	• 3" Pressure Relief Valve	1
Pressure Relief Valves	• Electronic Butterfly Valve - 2-6"	2
Regulation EBVs	• Data Industrial 220 Series Flowmeter, Brass	1
Flow Meter	• Wetwell Level Control w/1 Pond Fill	1
Level Controls	• Pump Station Base - Formed Steel	1
Pump Station Base	• Skid Shim Kit, Stainless Steel	1
Pump Station Base Accessories	• Station Disconnect Switch - 200A Fused	1
Disconnects VFDs	• Variable Frequency Drive, 50HP, 380-480V/3ph	1
XL Contactors	• VFD (XL) Contactor - 460-575V/3Ph - 50HP	2
	• Motor Starter - 460-575V/3Ph - 5HP	1
Control Systems	• Type 1- Sigma PLC Logic Controller	1
	• Power - Phase Monitor Protection	1
	• VirtualVision III - 7.0" Color LCD Touchscreen	3
Touchscreen Displays	• Lighted HOA Switch	1
Control Switches	• Standard Surge/Lightning Protection	1
Surge Protection	• Flow Sensor Opto Isolator	1
Optical Isolators	• Remote Disable Relay - 24VAC/DC	1
Remote Start Options	• WaterVision-PC with Pump Link and Banner Radios	1
Communication and RTUs	• Electrical Enclosure - 75x48x16 STL/WHT	1
Electrical Enclosures	• Heat Exchanger - Large (5-12K Btu)	1
Electrical Enclosure Cooling	• Operation & Maint Manual (English) - Electronic Copy	3
Documentation	• Omni antenna for office Watervision radio	1
Custom Option	• Yagi Antenna for pump station Watervision radio	1

PRICE (INCLUDES ALL ABOVE):

Set-Up by Granite Peak Pump Service, Inc.	\$107,945.00
Start-Up by Granite Peak Pump Service, Inc.	Included
Freight from factory to Job Site	Included
Equipment to Off-Load and Set Pump Station	Not Included
Local sales tax if applicable	Not Included

Shipment: Estimated 8 weeks after receipt of signed contract

OPTIONAL EQUIPMENT NOT INCLUDED IN TOTAL STATION PRICE: PRICE ACCEPTED
(Indicate acceptance of an Option by initialing each one being added to purchase)

- 5 KVA power supply shall be provided for auxiliary customer loads. The power supply shall consist of a minimum 8 place MEMA 3R load center, resin filled power transformer, fused disconnect and convenience outlet mounted on a heavy duty steel stand or statin enclosure where applicable. The power supply shall produce a minimum of 40A/20A @ 120/240VAC with 460-480VAC input voltage.

\$4,230.00 _____
- 8 ea. 15 amp – 2 pole circuit breakers shall be provided. The breaker shall be of correct type for use with the unregulated supply load center.

\$650.00 _____
- A 5-KVA pump house heater shall be provided and mounted to the back side of the power supply rack. The unit shall include an integrated 40-120F temperature control thermostat. A separate disconnect and branch circuit protection shall be provided that will allow the heater power to be controlled independently of the station main electrical panel.

\$2,975.00 _____

TERMS AND CONDITIONS

DELIVERY AND SETUP:

1. All reasonable efforts will be made to meet the requested delivery date after the receipt of a signed contract.
2. Pump station components shipped separately from the station, at the Customer's request, may incur additional freight charges, payable by the Customer.
3. Customer will be responsible for having job site readily accessible for station delivery via flatbed truck.
4. Customer will provide the equipment and personnel required to unload and/or set the pump station.
5. Station Set-up includes one day on site. If more than one day is required, additional charges of \$950.00 per day will be assessed if the customer caused the delay. Travel time not included if separate service call is required. MISSING EQUIPMENT from the Bill of Materials (BOM) must be identified within 2 weeks of delivery.
6. Customer will be responsible for electrical permit if required.
7. Customer will be responsible for primary electrical hookup to pump station.
8. Customer will be responsible for making all piping connections.
9. Customer will be responsible for building modifications (roof removal & installation) if required.
10. Customer will be responsible for wet well, slab, and concrete work.

START-UP:

1. Customer is responsible to guarantee the following before station calibration can be performed: a.) Permanent utility power is available and installed on pump station disconnect, b.) adequate water supply to operate station to full capacity, c.) installed irrigation system to operate station to full capacity. Start-up includes one day on site. If more than one day is required, additional charges of \$950.00 per day will be assessed if the customer caused the delay.
2. Purchaser will notify Granite Peak Pump Service two weeks in advance of the desired start-up date.

POWER SUPPLY:

1. The pump station proposed herein is designed for 480 volt, WYE configured or closed delta balanced 3 phase power. The acceptable range of voltage is 455 volts (min) — 495 volts (max). Unless specifically stated under Optional Equipment, open delta, phase converter, or other forms of unbalanced three phase power are not acceptable.
2. If the supply voltage is not within this acceptable range, the purchaser is responsible for making the necessary corrections. This may include re-tapping or replacing the primary transformer. If the supply voltage is outside the stated range, electrical components such as VFD's, fuses, breakers, overloads, motors, power supplies may intermittently trip or prematurely fail and will not be considered for warranty coverage.
3. The use of generator power is not recommended. If a generator is required as a temporary power supply, the pump station will be covered under Watertronics' limited warranty provided that their "Engine Driven Generator Power Warranty Policy and Operation Guidelines" document is strictly adhered to.
4. Proper electrical grounding of the pump station is a requirement. Station will not operate properly and could pose a health hazard if not properly grounded. Failures of any magnitude due to improper grounding will not be covered under warranty.

WATERTRONICS FACTORY WARRANTY:

1. Watertronics warrants its pump station products to be free of defects in materials and workmanship for a period of two (2) years from the date of startup, but not later than 27 (27) months from the date of invoice, unless modified by customer with the selection of the extended warranty option. Stations deemed delivery complete and invoiced accordingly, at Watertronics' factory and stored there, shall have the warranty period commence as of the invoice date. Should the system require storage before startup after leaving the Watertronics' facility, the system must be stored in a secured, climate controlled environment that will not allow for degradation of the system due to moisture, extreme temperature variations, or human negligence.
2. This warranty is limited to replacing or repairing any defective component supplied by Watertronics at Watertronics' sole discretion and does not apply to equipment that has been damaged, misapplied or has been modified in any way.
3. Any work performed on the pump station must be provided by a Watertronics recognized PSN (Pump Service Network) service provider and documentation of all work performed within the warranty period must be on file at the factory. Any maintenance or repairs done without the pre-authorization of Watertronics, or its recognized service providers shall void this warranty.
4. This warranty does not cover damages under the following conditions, unless otherwise specified in writing: (1) Misapplied or inappropriate incoming power, improper grounding, vandalism, or any incidental damage, consequential damage, or act of God, (2) repairs or replacements made without the pre-authorization of Watertronics, or its recognized service providers, (3) exposure to destructive gaseous or chemical solutions, (4) exposure to water pH levels of less than 6.0 which is typically the result of SO2 burner or sulfuric acid injection, (5) water salinity levels greater than 2000 parts per million, (6) water from a reverse osmosis process plant, (7) unusually high dirt load or abrasives in the water, or (8) pumping water not suitable for turf irrigation.
5. Watertronics will not accept liability for any costs associated with the removal or replacement of equipment in difficult to access locations. This includes, but is not limited to, the use of cranes larger than 15 tons, scuba divers, barges, helicopters, or other unusual means. These extraordinary costs shall be borne by the owner, regardless of the reason necessitating removal of the product from service.

6. THIS WARRANTY IS ABSOLUTELY IN LIEU OF ANY OTHER EXPRESS OR IMPLIED WARRANTIES. THIS INCLUDES ANY IMPLIED WARRANTY OF MERCHANTABILITY OR FITNESS FOR A PARTICULAR PURPOSE, AND OF ANY OTHER OBLIGATION ON THE PART OF WATERTRONICS.

NO AGENT, EMPLOYEE OR REPRESENTATIVE OF WATERTRONICS HAS ANY AUTHORITY TO BIND WATERTRONICS TO AN AFFIRMATION, REPRESENTATION OR WARRANTY CONCERNING THE PRODUCT SOLD UNDER THIS WARRANTY. THERE ARE NO WARRANTIES WHICH EXTEND BEYOND THE DESCRIPTION ON THE FACE HEREOF.

PAYMENT TERMS: U.S. DOLLARS ONLY

1. All purchase orders are subject to acceptance at Granite Peak Pump Service. Receipt of Production deposit, verification of acceptable credit and confirmation of order are required before production.

OTHER INFORMATON:

1. Prices valid for sixty (60) days from the date of this proposal.
2. State and local sales taxes are not included in these prices.
3. Seller retains a security interest in the above mentioned equipment as provided by the UNIFORM COMMERCIAL CODE, until payment is received in full.
4. All claims for incorrect deliveries must be submitted in writing to Granite Peak Pump Service within 15 days after receipt of goods.

PUMP STATION SPECIFICATIONS:

NAME: CASPER MUNICIPAL LINKS 9

STATION MODEL:

VTV-1-50x2/5ST-460-3-950-135

STATION TOTAL PERFORMANCE:

950 GPM @ 135 PSI

PUMP HORSEPOWER:

SUSTAIN PUMP: 5HP

PUMP NO.1-2: 50HP

CHECK VALVE SIZE

SUSTAIN: 2"

PUMP NO.1-2: 6"

ISOLATION VALVE SIZES:

SUSTAIN PUMP: 2"

PUMP NO.1-3: 4"

DISCHARGE ISOLATION VALVE: 6"

RELIEF VALVE SIZE: 3"

PUMP STATION DISCONNECT: 200 AMP

POWER REQUIREMENTS:

460V, 60 HZ, 3 PZ, 143 FLA

EXHAUST FAN REQ'D FOR BUILDING:

1785 CFM

WET WELL DIMS: Ø60"

WET WELL DEPTH: 14'-0"

MAIN LINE CONNECTION: 6" FL

NOMINAL PIPE SIZE: N/A

ACTUAL O.D.: N/A

TYPE:

DROP PIPE COVER: N/A

INTAKE FLUME SIZE: N/A

INTAKE FLUME MATERIAL: N/A

PLEASE VERIFY ALL INFO WITH
YOUR INITIALS AND DATE

INITIAL DATE

_____	_____
_____	_____
_____	_____
_____	_____
_____	_____
_____	_____
_____	_____
_____	_____
_____	_____
_____	_____

PLEASE INDICATE POWER SUPPLY CONDITION BELOW FOR
FCC COMPLIANCE. REFER TO WATERTRONICS DRAWING #
FCC-1 FOR ADDITIONAL INFORMATION

- A: CONNECTED THROUGH A COMMERCIAL BUILDING
- B: CONNECTED THROUGH A DEDICATED TRANSFORMER
- C: CONNECTED THROUGH A PAD TRANSFORMER SHARED WITH OTHER NON-RESIDENTIAL EQUIPMENT.
- D: CONNECTED TO A POLE TRANSFORMER ON A RESIDENTIAL POWER GRID.
- E: CONNECTED TO A PAD TRANSFORMER SHARED WITH RESIDENTIAL DWELLINGS.

PLEASE USE THE SPACE BELOW FOR ANY ADDITIONAL COMMENTS:

APPROVED AS SUBMITTED

APPROVED AS NOTED

REVISE AND RESUBMIT

REVIEWED BY: _____

NAME: _____

DATE: _____

DIMENSIONS AND SIZES OF EXISTING STRUCTURES, AND/OR COMPONENTS MUST BE VERIFIED TO WATERTRONICS BEFORE STATION CONSTRUCTION BEGINS.

UNLESS SPECIFIED BY THE CUSTOMER, PUMP HOUSE/CONCRETE SLAB DIMENSIONS ARE RECOMMENDED MINIMUMS FOR NEC AND SERVICE CLEARANCE, AND ARE FOR ILLUSTRATION PURPOSES ONLY. PROJECT MANAGER SHALL BE CONSULTED ON FINAL DESIGN.

THE PUMP STATION PROPOSED HEREIN IS DESIGNED TO BE PLACED IN A PUMP HOUSE FOR PROTECTION FROM THE ENVIRONMENT. IF A PUMP HOUSE IS NOT USED, WATERTRONICS MUST BE NOTIFIED AT TIME OF QUOTATION SO SPECIAL PROVISIONS CAN BE MADE.



PHONE: 1-262-367-5000
FAX: 1-262-367-5551

SHEET 1 OF 3 SHEETS

DRAWING NO.	PRVT12428	11/04/2019
	REV 1	6/5/20

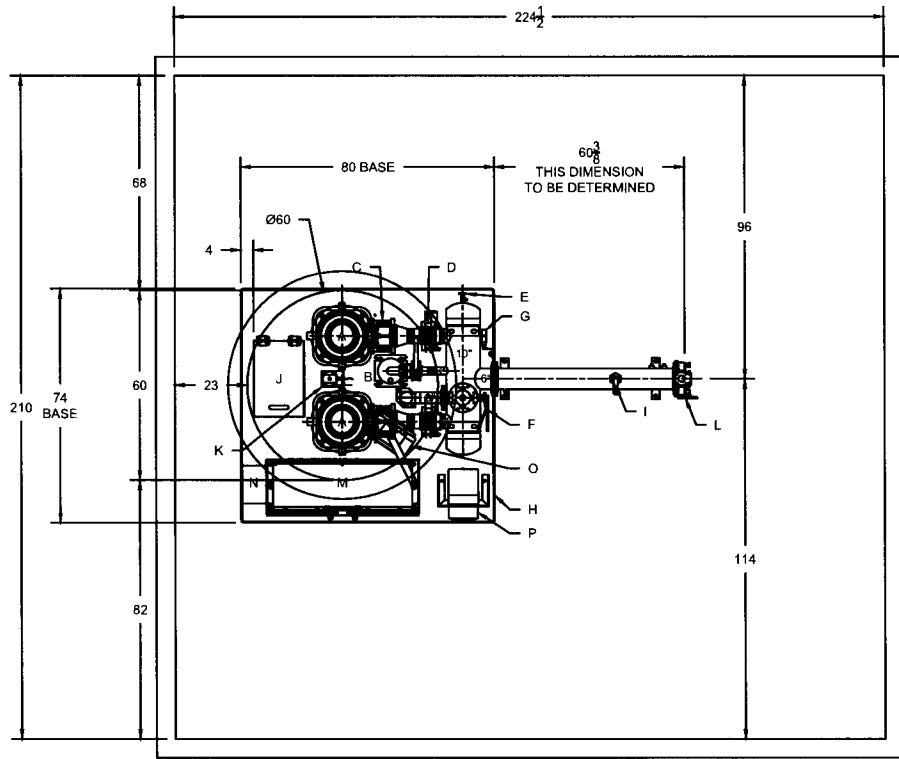

CONCEPT DRAWING ONLY
NOT TO BE USED FOR CONSTRUCTION

PLAN VIEW

[VTVQ]

- STATION COMPONENTS:
 A 50HP PUMP AND MOTOR
 B 5HP PRESSURE MAINTENANCE PUMP
 C CHECK VALVE
 D PUMP ISOLATION VALVE W/ EBV'S
 E DRAIN
 F 3" PRESSURE RELIEF VALVE
 G PRESSURE TRANSDUCER W/ GAUGE
 H PAINTED STEEL BASE (SANDSTONE)
 I FLOW SENSOR
 J 24" X 16" HATCH
 K LEVEL SENSOR
 L STATION ISOLATION VALVE
 M 754816 CONTROL CABINET
 N HEAT EXCHANGER
 O 5KW HEATER
 P 5KVA POWER PACK - UNREGULATED W/ QTY.8
 15AMP 2 POLE BREAKERS

7											DRAWN BY: ESP	DATE: 11/04/19	
6											CHECKED BY: ---	DATE: 00/00/00	
5											THIS DRAWING AND DESIGN IS THE PROPERTY OF WATERTRONICS AND IS NOT TO BE REPRODUCED IN WHOLE OR PART, NOR EMPLOYED FOR ANY PURPOSE OTHER THAN SPECIFICALLY PERMITTED IN WRITING BY WATERTRONICS. THIS DRAWING LOANED AND SUBJECT TO RETURN ON DEMAND		
4													
3													
2													
1	6/5/2020	ESP											ADDED HEATER & 5KVA POWER PACK
NO.	DATE	BY									DESCRIPTION	CHK DATE	CHK BY

TITLE:
 CASPER MUNICIPAL LINKS 9
 VTV-1-50x2/5ST-460-3-950-135

SCALE: NTS SHEET 2 OF 3 SHEETS
 JOB NO.: --- DRAWING NO. PRVT12428

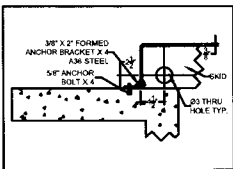
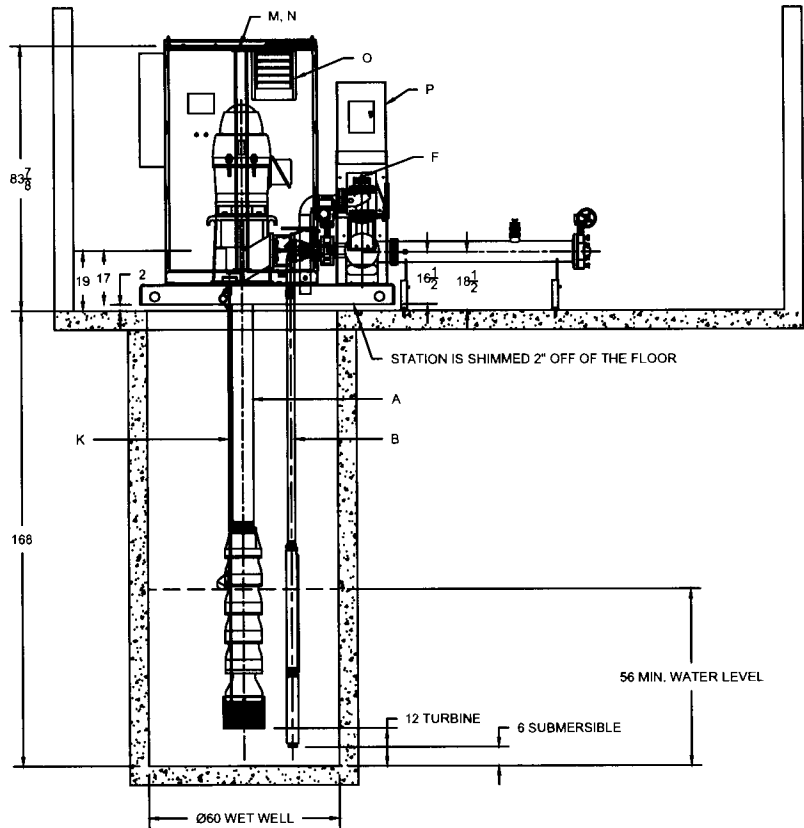

LIFTING HOLE/ ANCHOR DETAIL
(HOLES AT ALL CORNERS - 8 TOTAL
ANCHORS AT 4 OPPOSITE CORNERS)

ELEVATION VIEW

7						DRAWN BY: ESP	DATE: 11/04/19	TITLE: CASPER MUNICIPAL LINKS 9 VTV-1-50x2/5ST-460-3-950-135	
6						CHECKED BY: —	DATE: 00/00/00		
5						THIS DRAWING AND DESIGN, IS THE PROPERTY OF WATERTRONICS AND IS NOT TO BE REPRODUCED IN WHOLE OR PART, NOR EMPLOYED FOR ANY PURPOSE OTHER THAN SPECIFICALLY PERMITTED IN WRITING BY WATERTRONICS. THIS DRAWING LOANED AND SUBJECT TO RETURN ON DEMAND			
4					SCALE: NTS				SHEET 3 OF 3 SHEETS
3					JOB NO.: —				DRAWING NO. PRVT12428
2									
1	6/5/20	ESP	ADDED HEATER & 5KVA POWER PACK	—	—				
NO.	DATE	BY	DESCRIPTION	CHK DATE	CHK BY				

RESOLUTION NO. 20-138

A RESOLUTION AUTHORIZING A PROFESSIONAL SERVICE CONTRACT WITH GRANITE PEAK PUMP SERVICE, INC., FOR THE SOLE SOURCE PURCHASE AND INSTALLATION OF A PUMP STATION FOR THE CASPER MUNICIPAL GOLF COURSE.

WHEREAS, the City of Casper desires to secure a firm to furnish and install a pump station at the Links Course at the Casper Municipal Golf Course; and,

WHEREAS, Granite Peak Pump Service, Inc. is ready, willing and able to provide a pump station, installation and software training.

NOW, THEREFORE, BE IT RESOLVED BY THE GOVERNING BODY OF THE CITY OF CASPER, WYOMING: That the Mayor is hereby authorized and directed to execute, and the City Clerk to attest, a Contract with Granite Peak Pump Station, Inc. for services more specifically delineated in the Contract.

BE IT FURTHER RESOLVED: That the City Manager is hereby authorized to make one-time payment, using approved funds, throughout the project as prescribed by the agreement, for a total amount not to exceed One Hundred Seven Thousand Nine Hundred Forty-Five Dollars and 00/100 (\$107,945.00).

PASSED, APPROVED, AND ADOPTED on this ____ day of _____, 2020.

APPROVED AS TO FORM:



CITY OF CASPER, WYOMING
A Municipal Corporation

ATTEST:

Fleur Tremel
City Clerk

Steven K. Freel
Mayor

June 3, 2020

MEMO TO: J. Carter Napier, City Manager 

FROM: Andrew Beamer, Public Services Director 
Terry Cottenoir, Engineer Technician
Cynthia Langston, Solid Waste Division Manager
Sean Orszulak, Solid Waste Superintendent

SUBJECT: Authorizing a Procurement of Goods Agreement with Air Gas USA LLC, in the Amount of \$52,495 for the Purchase and Installation of a Machitech Silver Model Plasma Table to be used in the Solid Waste Division.

Meeting Type & Date:
Regular Council Meeting
July 7, 2020

Action Type:
Resolution

Recommendation:
That Council, by resolution, authorize a procurement of goods agreement with Air Gas USA LLC (Airgas), in the Amount of \$52,495, for the purchase of a Machitech Silver Model Plasma Table and Software Training, Project No. 19-063, to be used in the Solid Waste Division.

Summary:
During the February 4, 2020 pre-meeting of the regular City Council Meeting, Council authorized a sole source purchase of a Machitech Silver Model Plasma Table from Airgas. Airgas ordered the plasma table in February, and the delivery date is expected to be in June 2020.

The Solid Waste Division replaces wear plates on the City's waste balers approximately every 4,000 hours of operation (18 months) at a cost of \$90,000. A plasma cutting table would be used by Solid Waste staff to cut wear plates instead of outsourcing, reducing the total project cost from \$90,000 to \$65,000. The investment to purchase a plasma cutting table would be recovered within two (2) projects.

Engineering Division staff advertised the project to procure the plasma table on December 15 and 22, 2019, and the bid opening was January 15, 2020. Three (3) manufacturers were contacted as well as a local vendor to encourage submission of a bid. No bids were received. Airgas, the local vendor, expressed interest and provided staff an estimate of \$52,495 including a 2-year parts warranty. Staff recommends a sole source purchase from Airgas in the amount of \$52,495.

Financial Considerations:

Funding will be from the Balefill Fund Reserves and is included in the FY20 Balefill budget.

Oversight/Project Responsibility:

Terry Cottenoir, Engineer Technician

Sean Orszulak, Solid Waste Division Superintendent

Attachments:

Resolution

Procurement of Goods Agreement

Procurement of Goods Agreement (Short Form)

This Procurement of Goods Agreement ("Agreement") is entered into on this 22 day of June, 2020, by and between the City of Casper, Wyoming, a Wyoming municipal corporation with offices located at 200 N. David St., Casper, Wyoming 82601 ("**Buyer**") and Airgas USA, LLC, a Delaware Limited Liability Company with offices located at 430 North McKinley Street, Casper, Wyoming 82601 ("**Seller**"), and together with Buyer, the "**Parties**", and each, a "**Party**").

RECITALS

WHEREAS, Seller is in the business of selling various goods, including Machitech Silver Cut Plasma Tables, accessories, and training software; and

WHEREAS, Buyer desires to purchase from Seller, and Seller desires to sell to Buyer the Goods.

NOW, THEREFORE, in consideration of the mutual covenants and agreements hereinafter set forth and for other good and valuable consideration, the receipt and sufficiency of which are hereby acknowledged, the parties hereto agree as follows:

1. **Sale of Goods.** Seller shall sell to Buyer and Buyer shall purchase from Seller the goods set forth on Exhibit A (the "**Goods**") in the quantities and at the prices and upon the terms and conditions set forth in this Agreement.
2. **Delivery Date.** Seller shall deliver the Goods in the quantities and on the date(s) specified in Exhibit A or as otherwise agreed in writing by the parties (the "**Delivery Date**"). Timely delivery of the Goods is of the essence. If Seller fails to deliver the Goods in full on the Delivery Date, Buyer may terminate this Agreement immediately by providing written notice to Seller, provided that Buyer has made the first payment for the Goods, as further set forth in Section 10 below.
3. **Quantity.** Seller shall deliver the quantities of the Goods specified in Exhibit A. If Seller delivers more than one (1) or less than one (1) of the quantity of Goods specified in Exhibit A, Buyer may reject all or any excess Goods. Any such rejected Goods shall be returned to Seller at Seller's risk and expense. If Buyer does not reject the Goods and instead accepts the delivery of Goods at the increased or reduced quantity, the Price for the Goods shall be adjusted on a pro-rata basis.
4. **Delivery Location.** All Goods shall be delivered to the address specified in Exhibit A (the "**Delivery Location**") during Buyer's normal business hours or as otherwise instructed by Buyer.
5. **Shipping Terms.** Delivery shall be made FCA manufacturer's facility, Incoterms® 2010 Rules, in accordance with the terms set forth in Exhibit A. Seller shall give written notice of shipment to Buyer when the Goods are delivered to a carrier for transportation. Seller shall provide Buyer all shipping documents, including the commercial invoice, packing list, bill of lading and any other documents necessary to release the Goods to Buyer within thirty (30) business days after Seller delivers the Goods to the transportation carrier.
6. **Title and Risk of Loss.** Title passes to Buyer upon delivery of the Goods at the place of shipment. Seller bears all risk of loss or damage to the Goods until delivery at the place of shipment.

7. Packaging. Seller shall properly pack, mark and ship Goods as instructed by Buyer and otherwise in accordance with applicable law and industry standards and shall provide Buyer with shipment documentation showing the Contract Reference Number, the quantity of pieces in shipment, the number of cartons or containers in shipment, Seller's name, the bill of lading number, and the country of origin.

8. Inspection and Rejection of Nonconforming Goods. Buyer has the right to inspect the Goods on or within a reasonable period of time after the Delivery Date. Buyer, at its sole option, may inspect all or a sample of the Goods, and may reject all or any portion of the Goods if it determines the Goods are nonconforming or defective. If Buyer rejects any portion of the Goods, Buyer has the right, effective upon written notice to Seller, to reject the Goods and require replacement of the rejected Goods. If Buyer requires replacement of the Goods, Seller shall, at its expense, within thirty (30) days replace the nonconforming Goods and pay for all related expenses, including, but not limited to, transportation charges for the return of the defective goods and the delivery of replacement Goods. Any inspection or other action by Buyer under this Section shall not reduce or otherwise affect Seller's obligations under this Agreement, and Buyer shall have the right to conduct further inspections after Seller has carried out its remedial actions. Any claim for shortage in Goods or parts thereof is waived by Buyer unless made in writing to Seller within thirty (30) days after the delivery of the final invoice therefor.

9. Price. Buyer shall purchase the Goods from Seller at the prices set forth in Exhibit A, as it may be modified from time to time by agreement of the Parties (the "Price"). Except as may be set forth on Exhibit A, the Price includes all packaging, transportation costs to the Delivery Location (subject to adjusted freight charges), insurance, customs duties and fees and applicable taxes, including, but not limited to, all sales, use, or excise taxes. No increase in the Price is effective, whether due to increased material, labor, or transportation costs or otherwise, without the prior written consent of Buyer.

10. Payment Terms. Buyer shall make progress payments on the basis of the schedule set forth below within thirty (30) days of receipt of an itemized invoice during the term of this Agreement. Buyer agrees to issue to Seller three (3) payments, scheduled as follows: First, upon execution of this Agreement, Buyer shall issue a fifty (50) percent down payment to Seller. Second, Buyer shall issue a forty (40) percent payment to Seller before delivery of the Goods. Third, Buyer shall issue the remaining ten (10) percent payment to Seller upon installation and written acceptance of the Goods. Buyer shall pay all properly invoiced amounts due to Seller within 30 days after Buyer's receipt of such invoice, except for any amounts disputed by Buyer in good faith. All payments hereunder must be in US dollars. In the event of a payment dispute, Buyer shall deliver a written statement to Seller no later than 15 days after invoiced amounts are delivered to the buyer on the disputed invoice listing all disputed items. The parties shall seek to resolve all such disputes expeditiously and in good faith. Seller shall continue performing its obligations under this Agreement notwithstanding any such dispute.

11. Setoff. Without prejudice to any other right or remedy it may have, Buyer reserves the right to set off at any time any amount owing to it by Seller against any amount payable by Buyer to Seller.

12. Warranties. Seller will, to the fullest extent possible, assign, transfer, or otherwise extend to Buyer all guarantees and warranties received from the manufacturer of Goods furnished hereunder. Otherwise, Seller's sole warranty is to replace or repair, at its option and free of charge, manufacturing defects in material and workmanship in the Goods, provided that Buyer delivers written notice of any such defect to Seller prior to the expiration of (i) six (6) months after the date of Goods shipment from Seller if the Goods are new, or (ii) the expiration of ninety (90) days after the date of shipment if the Goods are used

or is designated for use in corrosive service. Such warranty shall only be valid if such Goods have been unaltered, properly cared for and operated under normal operating conditions. Seller assumes no obligation, liability, cost or responsibility for any repair or replacement unless performed by Seller or with Seller's prior written consent. Seller shall have no obligation for any defects in Goods, components thereof or replacement parts thereof that have been caused by failure to perform recommended normal maintenance, use of components, parts, peripherals, attachments, accessories, and/or perishable tooling not provided to Buyer by Seller (or not approved by Seller), accident, misuse, neglect, abuse, mishandling, misapplication, modification, alteration, or improper installation, service or maintenance. Except for the warranties expressly set forth above, SELLER MAKES NO WARRANTY OF ANY KIND OR NATURE WHATSOEVER, EITHER EXPRESS OR IMPLIED, IN FACT OR BY LAW. SELLER SPECIFICALLY DISCLAIMS ANY IMPLIED WARRANTY OF MERCHANTABILITY OR FITNESS FOR ANY PARTICULAR PURPOSE, INCLUDING, WITHOUT LIMITATION, ANY PURPOSE INTENDED BY BUYER, AND ANY WARRANTY AS TO THE ACCURACY OF THE GOODS, PERFORMANCE CAPABILITIES, OPERATING OR PROCESSING RESULTS OR CONSUMPTION OF UTILITIES.

13. Compliance with Law. Seller is in compliance with and shall comply with all applicable laws, regulations, and ordinances applicable to this Agreement. Seller has and shall maintain in effect all the licenses, permissions, authorizations, consents, and permits that it needs to carry out its obligations under this Agreement.

14. General Indemnification. Seller agrees to indemnify Buyer, Buyer's employees, elected officials, appointed officials, agents, and volunteers, and hold them harmless from all liability asserted by third parties for damages to property or injury to or death to persons, including all reasonable costs, expenses, and attorney's fees incurred related thereto, to the extent resulting from the negligence, fault or willful misconduct of Seller and any subcontractor thereof while at Buyer's facility.

15. Intellectual Property Indemnification. Seller shall, at its expense, defend, indemnify, and hold harmless Buyer, Buyer's employees, elected officials, appointed officials, agents, and volunteers against any and all liability arising out of or in connection with any claim that Buyer's or Indemnified Party's use or possession of the Goods infringes or misappropriates the patent, copyright, trade secret or other intellectual property right of any third party. In no event shall Seller enter into any settlement without Buyer's or Indemnified Party's prior written consent.

16. Insurance. Before commencing with any work under this Agreement at Buyer's facility, and for a period of one (1) year after the date of this Agreement, Seller shall, at its own expense, maintain and carry insurance in full force and effect that includes, but is not limited to, commercial general liability (including product liability) with limits of \$250,000 for each occurrence and \$500,000 in the aggregate with financially sound and reputable insurers. Seller shall provide Buyer with a certificate of insurance from Seller's insurer evidencing the insurance coverage specified in this Agreement.

17. Termination. In addition to any remedies that may be provided under this Agreement, Buyer may terminate this Agreement with immediate effect upon written notice to Seller, either before or after the acceptance of the Goods, if Seller has not performed or complied with any of the terms and conditions of this Agreement, in whole or in part, and has not corrected such failure within thirty (30) days following receipt of written notice thereof. If Seller becomes insolvent, is generally unable to pay, or fails to pay, its debts as they become due, files a petition for bankruptcy or commences or has commenced against it proceedings relating to bankruptcy, receivership, reorganization, or assignment for the benefit of creditors, then Buyer may terminate this Agreement upon written notice to Seller. If Buyer terminates

this Agreement for any reason, Seller's sole and exclusive remedy is payment for the Goods received and accepted by Buyer prior to the termination.

18. Confidential Information. All non-public, confidential, or proprietary information of the Buyer, including, but not limited to, specifications, samples, patterns, designs, plans, drawings, documents, data, business operations, customer lists, pricing, discounts, or rebates, disclosed by Buyer to Seller, whether disclosed orally or disclosed or accessed in written, electronic or other form or media, and whether or not marked, designated, or otherwise identified as "confidential," in connection with this Agreement is confidential, solely for the use of performing this Agreement and may not be disclosed or copied (except to the extent necessary to perform this Agreement) unless authorized by Buyer in writing. Upon Buyer's request, Seller shall promptly return all documents and other materials received from Buyer; provided that, Seller may retain copies of summaries and documents prepared for senior management relating to the scope of this Agreement, as well as copies of such material and derivative information stored in Seller's electronic archives maintained in the ordinary course of business solely for back up purposes. Buyer shall be entitled to injunctive relief for any violation of this Section. This Section shall not apply to information that is: (a) in the public domain; (b) known to the Seller at the time of disclosure; or (c) rightfully obtained by the Seller on a non-confidential basis from a third party.

19. Entire Agreement. This Agreement, including and together with any related exhibits, schedules, attachments, and appendices, constitutes the sole and entire agreement of the Parties with respect to the subject matter contained herein and supersedes all prior and contemporaneous understandings, agreements, representations and warranties, both written and oral, regarding such subject matter.

20. Survival. Subject to the limitations and other provisions of this Agreement: (a) the representations and warranties of the Parties contained herein shall survive the expiration or earlier termination of this Agreement; and (b) as well as any other provision that, in order to give proper effect to its intent, should survive such expiration or termination, shall survive the expiration or earlier termination of this Agreement. All other provisions of this Agreement shall not survive the expiration or earlier termination of this Agreement.

21. Notices. All notices, requests, consents, claims, demands, waivers, and other communications under this Agreement (each, a "Notice", and with the correlative meaning "Notify") must be in writing and addressed to the other Party at its address set forth below (or to such other address that the receiving Party may designate from time to time in accordance with this Section). Unless otherwise agreed herein, all Notices must be delivered by personal delivery, nationally recognized overnight courier or certified or registered mail (in each case, return receipt requested, postage prepaid). Except as otherwise provided in this Agreement, a Notice is effective only (a) on receipt by the receiving Party, and (b) if the Party giving the Notice has complied with the requirements of this Section.

Notice to Buyer:

200 North David Street
Casper, Wyoming 82601

Telephone: (307) 235-8341

Notice to Seller:

430 North McKinley Street
Casper, Wyoming 82601

22. Severability. If any term or provision of this Agreement is invalid, illegal, or unenforceable in any jurisdiction, such invalidity, illegality, or unenforceability shall not affect any other term or provision of this Agreement or invalidate or render unenforceable such term or provision in any other jurisdiction. Upon a determination that any term or provision is invalid, illegal, or unenforceable, the Parties shall negotiate in good faith to modify this Agreement to effect the original intent of the Parties as closely as possible in order that the transactions contemplated hereby be consummated as originally contemplated to the greatest extent possible.

23. Amendments. No amendment to, or modification of this Agreement is effective unless it is in writing and signed by an authorized representative of each Party.

24. Waiver. No waiver by any party of any of the provisions of this Agreement shall be effective unless explicitly set forth in writing and signed by the party so waiving. Except as otherwise set forth in this Agreement, no failure to exercise, or delay in exercising, any rights, remedy, power, or privilege arising from this Agreement shall operate or be construed as a waiver thereof, nor shall any single or partial exercise of any right, remedy, power or privilege hereunder preclude any other or further exercise thereof or the exercise of any other right, remedy, power, or privilege.

25. Cumulative Remedies. All rights and remedies provided in this Agreement are cumulative and not exclusive, and the exercise by either Party of any right or remedy does not preclude the exercise of any other rights or remedies that may now or subsequently be available at law, in equity, by statute, in any other agreement between the Parties, or otherwise. Notwithstanding the foregoing, the Parties intend that, if Buyer terminates the Agreement in accordance with Section 17, Seller's sole and exclusive remedy is the right to payment for the Goods received and accepted.

26. Assignment. Seller shall not assign, transfer, delegate, or subcontract any of its rights or obligations under this Agreement without the prior written consent of Buyer. Any purported assignment or delegation in violation of this Section shall be null and void. No assignment or delegation shall relieve the Seller of any of its obligations hereunder. Buyer may at any time assign, transfer or subcontract any or all of its rights or obligations under this Agreement without Seller's prior written consent.

27. Successors and Assigns. This Agreement is binding on and inures to the benefit of the Parties to this Agreement and their respective permitted successors and permitted assigns.

28. No Third-Party Beneficiaries. This Agreement benefits solely the Parties to this Agreement and their respective permitted successors and assigns and nothing in this Agreement, express or implied, confers on any other Person any legal or equitable right, benefit, or remedy of any nature whatsoever under or by reason of this Agreement.

29. Choice of Law. This Agreement, including all exhibits, schedules, attachments, and appendices attached hereto, and all matters arising out of or relating to this Agreement, are governed by, and construed in accordance with, the laws of the State of Wyoming, United States of America, without regard to the conflict of laws provisions thereof to the extent such principles or rules would require or permit the application of the laws of any jurisdiction other than those of the State of Wyoming.

30. Choice of Forum. Each Party irrevocably and unconditionally agrees that it will not commence any action, litigation, or proceeding of any kind whatsoever against the other Party in any way arising from or relating to this Agreement, including all exhibits, schedules, attachments, and appendices attached to this Agreement, and all contemplated transactions, including contract, equity, tort, fraud, and statutory claims, in any forum other than the courts of the State of Wyoming, sitting in Casper, Wyoming, and any appellate court from any thereof. Each Party irrevocably and unconditionally submits to the exclusive jurisdiction of such courts and agrees to bring any such action, litigation or proceeding only in the courts of the State of Wyoming sitting in Casper, Wyoming. Each Party agrees that a final judgment in any such action, litigation, or proceeding is conclusive and may be enforced in other jurisdictions by suit on the judgment or in any other manner provided by law.

31. Counterparts. This Agreement may be executed in counterparts, each of which is deemed an original, but all of which together are deemed to be one and the same agreement. Notwithstanding anything to the contrary in Section 21 (Notices), a signed copy of this Agreement delivered by facsimile, email or other means of electronic transmission is deemed to have the same legal effect as delivery of an original signed copy of this Agreement.

32. Force Majeure. Any delay or failure of either Party to perform its obligations under this Agreement will be excused to the extent that the delay or failure was caused directly by an event beyond such Party's control, without such Party's fault or negligence and that by its nature could not have been foreseen by such Party or, if it could have been foreseen, was unavoidable (which events may include natural disasters, embargoes, epidemics, explosions, riots, wars, or acts of terrorism) (each, a "Force Majeure Event"). Seller's financial inability to perform, changes in cost or availability of materials, components or services, market conditions or supplier actions or contract disputes will not excuse performance by Seller under this Section. Seller shall give Buyer prompt written notice of any event or circumstance that is reasonably likely to result in a Force Majeure Event, and the anticipated duration of such Force Majeure Event. Seller shall use all diligent efforts to end the Force Majeure Event, ensure that the effects of any Force Majeure Event are minimized and resume full performance under this Agreement.

33. Relationship of the Parties. The relationship between the parties is that of independent contractors. Nothing contained in this Agreement shall be construed as creating any agency, partnership, franchise, business opportunity, joint venture, or other form of joint enterprise, employment or fiduciary relationship between the parties, and neither party shall have authority to contract for or bind the other party in any manner whatsoever. No relationship of exclusivity shall be construed from this Agreement.

34. Wyoming Governmental Claims Act. Buyer does not waive any right or rights it may have pursuant to the Wyoming Governmental Claims Act, Wyoming Statutes Section 1-39-101 et seq., and Buyer specifically reserves the right to assert any and all rights, immunities, and defenses it may have pursuant to the Wyoming Governmental Claims Act.

35. Limitation of Liability/Remedies. Except for Seller's negligence in the installation of and training in the use of the Goods, Seller shall not be liable for injury, death, loss or damage of any kind arising in any manner, directly or indirectly, from any delay, act, error or omission of Seller, or from the Goods or their presence or use, whether singly or in combination with other equipment, or for explosion. IN NO EVENT SHALL SELLER BE LIABLE FOR LOSS OF PROFITS OR INCIDENTAL, INDIRECT, SPECIAL, CONSEQUENTIAL OR OTHER SIMILAR DAMAGES ARISING OUT OF ANY BREACH OF THIS AGREEMENT OR OTHERWISE.

36. Buyer Responsibilities. The determination of the suitability, compatibility and uses of the Goods are

the sole responsibility of Buyer, which assumes all risk and liability for loss, damage and injury or death; and Seller disclaims any liability, responsibility or obligation whatsoever in connection therewith. Buyer assumes all risk of loss and liability for any and all loss, damage or injury to persons (including death) or property of Buyer or others arising out of ownership, use, custody, control, or disposition of Goods by Buyer, its agents or employees, or by any third parties, except to the extent directly resulting from the negligence or willful misconduct of Seller. Buyer shall be responsible for (i) acquiring all necessary permits and government approvals related to installation of the Goods, and (ii) complying with all applicable laws, ordinances, orders, rules and regulations pertaining to the Goods and their ownership, use, custody, control, and disposition.

IN WITNESS WHEREOF, the undersigned duly authorized representatives of the parties have executed this Contract as of the day and year above.

APPROVED AS TO FORM

Walke Tronzo

ATTEST

BUYER
CITY OF CASPER, WYOMING
A Wyoming municipal corporation

Fleur Tremel
City Clerk

Steven K. Freel
Mayor

WITNESS

SELLER
Airgas USA, LLC

By: Eva Kreil
Printed Name: EVA KREIL
Title: Executive Assistant

By: Michael E. Hatton
Printed Name: MICHAEL EATMON
Title: REGIONAL PRESIDENT

EXHIBIT A

- DESCRIPTION AND QUANTITY OF GOODS:
 - Machitech Silver Cut Plasma Table
 - Six Foot (6') x Twelve Foot (12') Cutting Dimensions
 - Six Foot (6') x Twelve Foot (12') Waterbed Material Support
 - Automatic Torch Height Control
 - Hypertherm Powermax 125
 - Machitech Silver Cut CNC Controller
 - Machitech Silver Cut CNC/CAD/CAM Software
 - Quick Change Oxyfuel Torch
 - Two (2) Days Installation and Training
 - Machitech Automation Products Parts Warranty: One (1) year OR Two Thousand (2,000) Operation Hours, whichever occurs first.
 - Hypertherm Plasma Products Parts Warranty: Two (2) years, expect for external parts (cables, torch lead, etc.) which have a one (1) year warranty.
 - Hypertherm Automation Products Warranty: Two (2) years parts.
- PRICE: Fifty-Two Thousand Four Hundred Ninety-Five Dollars (\$52,495.00)
- DELIVERY DATE: August 31, 2020
- DELIVERY LOCATION:

City of Casper Regional Solid Waste Facility
1886 North Station Road
Casper, Wyoming 82601

SHIPPING TERMS: Delivery shall be made FCA Manufacturer's Facility, Incoterms® 2010 Rules.

Reasonable shipping costs shall be agreed upon by Buyer and Seller in the form of a written change order at a mutually agreed time prior to the shipment of the Goods.

RESOLUTION NO.20-139

A RESOLUTION AUTHORIZING A PROCUREMENT OF GOODS AGREEMENT WITH AIRGAS USA, LLC, FOR THE SOLID WASTE PLASMA TABLE.

WHEREAS, the City of Casper desires to acquire a Machitech Silver Cut Model Plasma Table, Accessories and Training Software for the Solid Waste Division; and,

WHEREAS, Airgas USA, LLC, is ready, willing and able to provide these services.

NOW, THEREFORE, BE IT RESOLVED BY THE GOVERNING BODY OF THE CITY OF CASPER, WYOMING: That the Mayor is hereby authorized and directed to execute, and the City Clerk to attest, a Procurement of Goods Agreement with Airgas USA, LLC, in the amount of Fifty-Two Thousand Four Hundred Ninety-Five Dollars (\$52,495.00), to furnish a Machitech Silver Cut Model Plasma Table, Accessories and Training Software.

PASSED, APPROVED, AND ADOPTED this _____ day of _____, 2020.

APPROVED AS TO FORM:



ATTEST:

CITY OF CASPER, WYOMING
A Municipal Corporation

Fleur Tremel
City Clerk

Steven K. Freel
Mayor

June 2, 2020

MEMO TO: J. Carter Napier City Manager 

FROM: Andrew B. Beamer, P.E., Public Services Director 
Bruce Martin, Public Utilities Manager
Scott R. Baxter, P.E., Associate Engineer

SUBJECT: Authorizing a Contract for Professional Services with Jacobs Engineering Group, in the amount of \$1,128,870, for the North Platte Sanitary Sewer Rehabilitation, Project No. 20-015.

Meeting Type & Date:

Regular Council Meeting
June 16, 2020

Recommendation:

That Council, by resolution, authorize a contract for professional services with Jacobs Engineering Group in the amount of \$1,128,870, for the North Platte Sanitary Sewer Rehabilitation, Project No. 20-015.

Summary:

The City of Casper owns nine (9) miles of sanitary sewer trunk line known as the North Platte Sanitary Sewer interceptor. The line includes pipe diameters from twenty-four inch (24"), starting at 2600 Yarrow on the west end, up to fifty-four inch (54") along Bryan Evansville Road as the pipe enters the Casper Regional Waste Water Treatment Facility. The trunk line is made of reinforced concrete pipe (RCP) that was installed in the early 1980's and has been corroding due to hydrogen sulfide and sulfuric acid. A study completed in 2012 by CH2M Hill revealed approximately two (2) miles of the pipeline, in various segments, that need the most critical attention and will be addressed in this project. These worst segments also include three (3) sewer main connections and approximately forty-five (45) manholes. The project goal is to rehab or replace the critical pipe sections while maintaining uninterrupted service and capacity in the system.

A request for proposals was sent to qualified consultants to furnish engineering design, bid support, and construction administration services for the project. The City received five (5) proposals from interested consultants. A selection committee consisting of City staff reviewed the proposals and interviewed three (3) of the consulting firms. The selection committee chose Jacobs Engineering Group based on their written proposal, interview and team qualifications. Jacobs Engineering Group's fee for the complete scope of services is \$1,128,870.

Jacobs Engineering Group
North Platte Sanitary Sewer Rehabilitation
Project No. 20-015

The design, bid support, and construction administration services for the project include preparation of construction plans and specifications, permitting work through Wyoming Department of Environmental Quality, assistance with advertising, opening, and evaluating construction bids, and complete inspection and project management during construction.

Financial Considerations:

Funding will be from Clean Water State Revolving Funds (CWSRF) in the form of a loan for up to \$8,000,000 with 25% principal forgiveness according to the agreement executed March 5, 2020 with the State Loan and Investment Board (SLIB).

Oversight/Project Responsibility:

Scott R. Baxter, Associate Engineer

Attachments:

Resolution
Agreement

CONTRACT FOR PROFESSIONAL SERVICES

PART I - AGREEMENT

This Contract for Professional Services (“Contract”) is entered into on this 16th day of June, 2020, by and between the following parties:

1. The City of Casper, Wyoming, a Wyoming municipal corporation, 200 North David Street, Casper, Wyoming 82601 (“City” and/or “Owner”).
2. Jacobs Engineering Group, Inc., 2725 Rocky Mountain Avenue, Suite 330, Loveland, Colorado 80538 (“Consultant”).

Throughout this document, the City and Consultant may be collectively referred to as the “parties.”

RECITALS

A. The City is undertaking a project to rehabilitate segments of its largest sanitary sewer interceptor pipe, otherwise known as the North Platte Sanitary Sewer Rehabilitation, Project No. 20-015.

B. The project requires professional services for the design, bidding, construction administration and warranty inspection in relation to the project.

C. Consultant represents that it is ready, willing, and able to provide the professional services to City as required by this Contract.

D. The City desires to retain Consultant for such services.

NOW, THEREFORE, in consideration of the covenants and conditions set forth herein to be performed, the parties agree as follows:

1. SCOPE OF SERVICES:

Consultant shall perform the following services in connection with and respecting the project as provided in Exhibit “A”, Page 1 of 16 through Page 16 of 16; and Exhibit “B”, Page 1 of 1, which are attached hereto and made a part of this Contract.

2. TIME OF PERFORMANCE:

The services of Consultant shall be undertaken and completed on or before the 31st day of May, 2023.

3. COMPENSATION:

In consideration of the performance of services rendered under this Contract, Consultant shall be compensated for services performed in accordance with paragraph 1, not to exceed sum of One Million One Hundred Twenty-Eight Thousand Eight Hundred Seventy and 00/00 Dollars (\$1,128,870.00).

4. METHOD OF PAYMENT:

Payment will be made following completion of the terms set forth herein and receipt of an itemized invoice, certified under penalty of perjury, from Consultant for services rendered in conformance with the Contract, and following approval by the Casper City Council. The invoice for payment must specify the correct amount due; that Consultant has performed the services rendered under this Contract, in conformance with the Contract, and that it is entitled to receive the amount requested under the terms of the Contract.

If amounts owed by Consultant to the City for any goods, services, licenses, permits or any other items or purpose remain unpaid beyond the City's general credit policy, those amounts may be deducted from the payment being made by the City to Consultant pursuant to this Contract.

5. TERMS AND CONDITIONS:

This Contract is subject to and incorporates the provisions attached hereto as PART II -- GENERAL TERMS AND CONDITIONS.

6. EXTENT OF CONTRACT:

This Contract represents the entire and integrated Agreement between the City and Consultant, and supersedes all prior negotiations, representations, or agreements, either written or oral. The Contract may be amended only by written instrument signed by both the City's and Consultant's authorized representatives.

The City and Consultant each individually represent that they have the requisite authority to execute this Contract and perform the services described in this Contract.

IN WITNESS WHEREOF, the undersigned duly authorized representatives of the parties have executed this Contract as of the day and year above.

APPROVED AS TO FORM

Walker Tremel

ATTEST

CITY OF CASPER, WYOMING
A Municipal Corporation

Fleur D. Tremel
City Clerk

Steven K. Freel
Mayor

WITNESS

CONSULTANT
Jacobs Engineering Group, Inc.

By: Kyle E. Snider

By: Albert Paquet

Printed Name: KILE E. SNIDER

Printed Name: Albert Paquet

Title: PROJECT MANAGER

Title: Vice President

CONTRACT FOR PROFESSIONAL SERVICES

PART II - GENERAL TERMS AND CONDITIONS

1. TERMINATION OF CONTRACT:

1.1 The City may terminate this Contract anytime by providing thirty (30) days written notice to Consultant of intent to terminate said Contract. In such event, all finished or unfinished documents, data, studies and reports prepared by Consultant under this Contract shall, at the option of the City, become its property, and Consultant shall be entitled to receive just and equitable compensation for any satisfactory work completed on such documents.

1.2 Notwithstanding the above, Consultant shall not be relieved of liability to the City for damages sustained by the City, by virtue of termination of the Contract by Consultant, or any breach of the Contract by Consultant, and the City may withhold any payments to Consultant for the purpose of setoff until such time as the exact amount of damages due the City from Consultant are determined.

2. CHANGES:

The City may, from time to time, request changes in the scope of the services of the Contract. Such changes, including any increase or decrease in the amount of Consultant's compensation, which are mutually agreed upon between the City and Consultant, shall be incorporated in written amendments to this Contract. There shall be no increase in the amount of Consultant's compensation unless approved by Resolution adopted by City.

3. ASSIGNABILITY:

Neither Party shall assign any interest in this Contract, and shall not transfer any interest in the same (whether by assignment or novation) without the prior written approval of the other party: provided, however, that claims for money due or to become due Consultant from the City under this Contract may be assigned to a bank, trust company, or other financial institution, or to a trustee in bankruptcy, without such approval. Notice of any assignment or transfer shall be furnished to the City within five (5) business days of any assignment or transfer.

4. AUDIT:

The City or any of its duly authorized representatives shall have access, during Consultant's normal business hours of 9 am to 5 pm, to any books, documents, papers, and records of Consultant which are directly pertinent to the Contract for the purpose of making audit, examination, excerpts, and transactions.

5. EQUAL EMPLOYMENT OPPORTUNITY:

In carrying out the program, Consultant shall not discriminate against any employee or applicant for employment because of race, color, religion, sex, national origin, or disability. Consultant shall take affirmative action to ensure that applicants for employment are employed, and that employees are treated during employment, without regard to their race, color, religion, sex, national origin, or disability. Such action shall include, but not be limited to, the following: employment upgrading, demotion, or transfer; recruitment or recruitment advertising; layoff or termination; rates of pay or other forms of compensation; and selection for training, including apprenticeship. Consultant shall post in conspicuous places, available to employees and applicants for employment, notices required by the government setting forth the provisions of this nondiscrimination clause. Consultant shall state that all qualified applicants will receive consideration for employment without regard to race, color, religion, sex, national origin, or disability.

6. OWNER OF PROJECT MATERIALS:

All finished or unfinished documents, data, studies, surveys, drawings, maps, model output data, photographs, films, duplicating plates, and reports prepared by Consultant under this Contract shall be considered the property of the City, and upon completion of the services to be performed, they will be turned over to the City provided that, in any case, Consultant may, at no additional expense to the City, make and retain such additional copies thereof as Consultant desires for its own use; and provided further, that in no event may any of the documents, data, studies, surveys, drawings, maps, models output data, photographs, films, duplicating plates, or other reports retained by Consultant be released to any person, agency, corporation, or organization without the written consent of the City. Consultant is not liable to the City for any claims, damages, losses, and costs, including, but not limited to litigation expenses and attorney's fees arising out of or related to the unauthorized reuse, change or alteration of these project documents.

7. FINDINGS CONFIDENTIAL:

All reports, information, data, etc., given to or prepared, or assembled by Consultant under this Contract are confidential and shall not be made available to any individual or organization by Consultant without the prior written consent of the City.

8. GOVERNING LAW:

This Contract shall be governed by the laws of the State of Wyoming. Consultant shall also comply with all applicable laws, ordinances, and codes of the local, state, or federal

governments and shall not trespass on any public or private property in performing any of the work embraced by this Contract.

9. PERSONNEL:

Consultant represents that it has, or will secure, all personnel required in performing the services under this Contract. Such personnel shall not be employees of the City. All of the services required shall be performed by Consultant, or under its supervision, and all personnel engaged in the work shall be fully qualified. All personnel employed by Consultant shall be employed in conformity with applicable local, state or federal laws.

10. SUBCONSULTANT:

Consultant shall not employ any subconsultant to perform any services in the scope of this project, unless the subconsultant is approved in writing by the City. Any approved subconsultant shall be paid by Consultant.

11. INSURANCE AND INDEMNIFICATION:

A. **Prior to the commencement of work, Consultant shall procure and maintain for the duration of the contract insurance against claims for injuries to persons or damages to property which may arise from or in connection with the performance of the work hereunder by Consultant, its subconsultants, agents, representatives, or employees.**

B. *Minimum Scope and limit of Insurance.*

Coverage shall be at least as broad as:

1. Commercial General Liability (CGL): Insurance Services Office Form CG 00 01 covering CGL on an "occurrence" basis, including products and completed operations, property damage, bodily injury and personal & advertising injury with limits of Two Hundred Fifty Thousand Dollars (\$250,000) to any claimant for any number of claims arising out of a single transaction or occurrence; or the sum of Five Hundred Thousand Dollars (\$500,000) for all claims arising out of a single transaction or occurrence. If a general aggregate limit applies, the general aggregate limit shall apply separately to this project/location. The CGL policy shall be endorsed to contain Employers Liability/Stop Gap Coverage.
2. Automobile Liability: Insurance Services Office Form Number CA 0001 covering, Code 1 (any auto), or if Consultant has no owned autos, Code 8 (hired) and 9 (non-owned), with limit of Five Hundred Thousand (\$500,000) per accident for bodily injury and property damage.

Workers' Compensation: as required by the State of Wyoming with Statutory Limits.

3. Professional Liability (Errors and Omissions) Insurance appropriate to Consultant's profession, with limits in the amount of Two Hundred Fifty Thousand Dollars (\$250,000) per claim and the sum of Five Hundred Thousand Dollars (\$500,000) general aggregate.

C. Other Insurance Provisions

The insurance policies are to contain, or be endorsed to contain, the following provisions:

1. *Additional Insured Status*

The City, its officers, elected and appointed officials, employees, and agents are to be covered as additional insureds on the CGL policy with respect to liability arising out of work or operations performed by or on behalf of Consultant including materials, parts, or equipment furnished in connection with such work or operations. General liability coverage shall be provided in the form of an endorsement to Consultant's insurance (at least as broad as ISO Form CG 20 10 11 85 or both CG 20 10 and CG 20 37 forms if later revisions used).

2. *Primary Coverage*

For any claims related to this contract with exception of Professional Liability Insurance, Consultant's insurance coverage shall be primary insurance as respects the City, its officers, elected and appointed officials, employees, agents and volunteers. Any insurance or self-insurance maintained by the City, its officers, elected and appointed officials, employees, agents or volunteers shall be excess of Consultant's insurance and shall not contribute with it.

3. *Notice of Cancellation*

Each insurance policy required above shall state that coverage shall not be canceled, materially adverse change, or reduced, except with notice to the City. Such notice to the City shall be provided in a commercially reasonable time.

4. *Waiver of Subrogation*

With exception of Professional Liability Insurance, Consultant hereby grants to City a waiver of any right to subrogation which any insurer of said Consultant may acquire against the City by virtue of the payment of any loss under such insurance. Consultant agrees to obtain any endorsement that may be necessary to affect this waiver of subrogation, but this provision applies regardless of whether or not the City has received a waiver of subrogation endorsement from the insurer.

5. *Deductibles and Self-Insured Retentions*

Consultant has two options regarding deductibles and self-insured retentions:

- a. Option 1: Any deductibles or self-insured retentions must be declared to and approved by the City. Unless otherwise approved by the City in writing, any deductible may not exceed Ten Thousand Dollars (\$10,000). Unless otherwise approved in writing by the City, self-insured retentions may not exceed Ten Thousand Dollars (\$10,000), and the City may require the Consultant to provide proof of ability to pay losses and related investigations, claim administration, and defense expenses within the retention.
- b. Option 2: Consultant shall carry insurance with terms that require its insurance company to pay the full value of a covered claim from the first dollar of coverage, even if Consultant is unable to pay any deductible or self-insured retention amount(s) required by the insurance policy. Consultant shall provide a written endorsement from its insurance carrier that such insurance coverage is in place, and shall keep such coverage in place during the term of this Contract and any subsequent time period required for claims made policies.

6. *Acceptability of Insurers*

Insurance is to be placed with insurers with a current A.M. Best's rating of no less than A:VII, unless otherwise agreed to in writing by the City.

7. *Claims Made Policies*

If any of the required policies provide coverage on a claims-made basis:

- a. The Retroactive Date must be shown and must be before the date of the contract or the beginning of contract work.
- b. Insurance must be maintained and evidence of insurance must be provided *for at least three (3) years after completion of the contract of work*. However, Consultant's liabilities under this Contract shall not be deemed limited in any way by the insurance coverage required.
- c. If coverage is canceled or non-renewed, and not *replaced with another claims-made policy form with a Retroactive Date* prior to the contract effective date, Consultant must purchase "extended reporting" coverage for a minimum of *three (3) years* after completion of contract work and at all times thereafter until the applicable statute of limitations runs.

8. *Verification of Coverage*

Consultant shall furnish the City with original certificates and amendatory endorsements or copies of the applicable policy language effecting coverage required by this clause. All certificates and endorsements are to be received and approved by the City before work commences. However, failure to obtain the required documents prior to the work beginning shall not waive Consultant's obligation to provide them. In the event of a claim, the City reserves the right to request copies of all required insurance policies, including endorsements required herein.

9. *Subconsultants*

Consultant shall require and verify that all subconsultants maintain insurance meeting all the requirements stated herein, and Consultant shall ensure that the City is an additional insured on insurance required from subconsultants.

10. *Special Risks or Circumstances*

City reserves the right to reasonably modify these requirements, including limits, based on the nature of the risk, prior experience, insurer, coverage, or other special circumstances.

D. Consultant agrees to indemnify the City, the City's employees, elected officials, and appointed officials and hold them harmless from all liability for damages to property or injury to or death to persons, including all reasonable costs, expenses, and attorney's fees incurred related thereto, to the extent arising from negligence of Consultant and any subconsultant thereof.

12. INTENT:

Consultant represents that it has read and agrees to the terms of this Contract and further agrees that it is the intent of the parties that Consultant shall perform all of the services for the compensation set forth in this Contract. Consultant also agrees that it is the specific intent of the parties, and a material condition of this Contract, that it shall not be entitled to compensation for other services rendered unless specifically authorized by the City by Resolution of its governing body. Consultant agrees that it has carefully examined the Scope of Services, and that the compensation is adequate for performance of this Contract.

13. WYOMING GOVERNMENTAL CLAIMS ACT:

The City does not waive any right or rights it may have pursuant to the Wyoming Governmental Claims Act, Wyoming Statutes Section 1-39-101 et seq., and the City specifically reserves the right to assert any and all rights, immunities, and defenses it may have pursuant to the Wyoming Governmental Claims Act.

14. NO THIRD PARTY BENEFICIARY RIGHTS:

The parties to this Contract do not intend to create in any other individual or entity the status of third-party beneficiary, and this Contract shall not be construed so as to create such status. The rights, duties and obligations contained in this Contract shall operate only between the parties to this Contract, and shall inure solely to the benefit of the parties to this Contract. The parties to this Contract intend and expressly agree that only parties signatory to this Contract shall have any legal or equitable right to seek to enforce this Contract, to seek any remedy arising out of a party's performance or failure to perform any term or condition of this Contract, or to bring an action for the breach of this Contract.

15. STANDARD OF CARE

The Standard of Care applicable to the Consultant's services will be the degree of skill and diligence normally employed by professional engineers or consultants performing the same or similar services at the time said services are performed. Consultant will reperform any services not meeting this standard without additional compensation.

16. FORCE MAJEURE

In the event Consultant is delayed in performance of services by Acts of God, strikes, lockouts, accidents, or other events beyond the control of Consultant, then Consultant's compensation and the schedule for this Contract shall be equitably adjusted. In the event delays to the services are encountered for any reason, the parties agree to undertake reasonable steps to mitigate the effect of such delays.

Exhibit A

Scope of Work for Design, Bid, and Construction Phase Services for North Platte Sanitary Sewer Interceptor Rehabilitation

for the

**City of Casper's Public Services Department
Engineering Division**

Project Description

The City of Casper (City) previously hired CH2M HILL Engineers, Inc. now doing business as Jacobs Engineering Group Inc. (Consultant) to complete a condition assessment of the City's North Platte Sanitary Sewer Interceptor (NPSSI) which is a sanitary sewer trunk line and part of the City's wastewater collection system. Among the findings of the condition assessment was that segments of the reinforced concrete pipe which comprises the NPSSI exhibited advanced corrosion which warranted rehabilitation.

This scope of work details the services to be rendered by Consultant for the design, bidding, and construction phase services for the North Platte Sanitary Sewer Interceptor Rehabilitation project (project). The project will consist of rehabilitation of portions of the NPSSI including:

- Trenchless pipeline repair of approximately 10,400 LF of the NPSSI.
- Repair or replacement of manholes associated with the repaired segments.
- Redesign of up to three drop manhole sidestream flow entrances to the NPSSI.

It is understood that the City will designate Mr. Scott Baxter, Associate Engineer, as the primary point of contact with respect to the work performed under this agreement, with authority to transmit instructions, receive information, interpret and make decisions relative to elements pertinent to the work covered by this Agreement, all subject to review and approval of the Public Services Director or City Manager, as necessary.

Civil Engineering Professionals, Inc. (CEPI) and BlueWater Solutions Group, Inc. (BlueWater) will be subconsultants (jointly referred to as Subconsultants) to Consultant for the project.

Basis of Design Scope and Fee Development

The following key assumptions were made in the compilation of this scope of work and the estimated level of effort:

1. City review will be conducted after design documents have been completed to both a 50 and 90 percent stage.
2. Project deliverables will be provided electronically in Portable Document Format (PDF). Distribution of electronic Bidding Documents may be achieved with a Consultant-provided File Transfer Protocol (FTP) site. Up to five hard copies of drawings and specifications will be provided for City use during design and bidding.
3. The design will be based on the federal, state, and local codes and standards in effect on the effective date of the authorization to proceed. Any changes in these codes may necessitate a change in scope.
4. The design documents will be prepared for up to two pipeline rehabilitation solutions in a single construction contract assuming an open bid.
5. Consultant master specifications will be used as the basis for all specifications, except for Division 0 and Division 1 documents which will be City standard documents.
6. Only a single vendor will be named for each manufactured component or piece of equipment with provisions for an "equal" to be proposed by the contractor and subject to approval by the Consultant.
7. No equipment or material pre-purchase or pre-negotiation will be required.

8. The drawings will follow Consultant CAD/CAE standards using a layering scheme coordinated and approved by the City including layer names. MicroStation will be used to develop the drawings along with PDF base drawings from prior projects.
9. Any investigation and remediation of possible hazardous waste, asbestos, lead paint, or other types of contamination will be conducted as a separate contract.
10. In providing opinions of cost, financial analyses, economic feasibility projections, and schedules for the Project, Consultant has no control over cost or price of labor and materials; unknown or latent conditions of existing equipment or structures that may affect operation or maintenance costs; competitive bidding procedures and market conditions; time or quality of performance by operating personnel or third parties; and other economic and operational factors that may materially affect the ultimate Project cost or schedule. Therefore, Consultant makes no warranty that City's actual Project costs, financial aspects, economic feasibility, or schedules will not vary from Consultant's opinions, analyses, projections, or estimates.
11. Design drawings may utilize prior pipeline as-built drawings as reference drawings or as backgrounds with new work shown on top of the previous construction.
12. The Contractor's construction period will last approximately 9 months, and Contractor's work will be completed by May 31, 2022. Consultant's work will be completed following the 12-month Contractor warranty period and by May 31, 2023.
13. The project will be constructed under one general contract for construction.
14. Labor and expenses, above the effort defined in this scope, required to address construction claims, unforeseen subsurface considerations or additional construction requested by the Contractor or City will constitute additional services.
15. Claims resolution or litigation assistance requested of Consultant, above and beyond those services specifically defined in this scope, will constitute additional services.
16. The City will give prompt notice to Consultant whenever City observes or becomes aware of any development that affects the scope or timing of Consultant's services, or of any defect in the work of Consultant or the Contractor.
17. The City will examine information submitted by Consultant and render in writing or otherwise provide decisions in a timely manner.
18. The City will furnish required information and approvals in a timely manner.
19. The resident project representative (RPR) will keep a copy of Contractor deliverables for City records. Contractor deliverables include: shop drawings, samples, certificates, construction photos, record documents, releases from liens, claims, agreements, contractor design data, manufacturer's instructions, operation and maintenance data, schedules, special guarantees, permits, test and inspection reports, testing and startup data, and training data.
20. Consultant will manage the health, safety, and environmental activities of its staff to achieve compliance with applicable health and safety laws and regulations. Consultant will coordinate with responsible parties to correct conditions that do not meet applicable federal, state, and local occupational safety and health laws and regulations, when such conditions expose Consultant staff, or City staff to unsafe conditions. Consultant is not responsible for health or safety precautions of construction workers. Consultant is not responsible for the Contractor's compliance with the health and safety requirements in the contract for construction, or with federal, state, and local occupational safety and health laws and regulations.

21. Recommendations by Consultant and Subconsultants to the City for periodic construction progress payments to the construction contractor(s) will be based on Consultant's knowledge, information, and belief from selective sampling that the work has progressed to the point indicated. Such recommendations do not represent that continuous or detailed examinations have been made by Consultant to ascertain that the construction Contractor has completed the work in exact accordance with the construction documents; that the final work will be acceptable in all respects; that Consultant has made an examination to ascertain how or for what purpose the construction Contractor has used the moneys paid; that title to any of the work, materials, or equipment has passed to the City free and clear of liens, claims, security interests, or encumbrances; or that there are no other matters at issue between the City and the construction Contractor that affect the amount that should be paid.

Scope of Work

The following is a description of the Consultant's scope of work for the project.

Task 1: Project Initiation and Data Review

Initial project scope is described in this task.

Subtask 1.1: Existing Documentation

- Consultant will request from the City and perform a review of existing documentation, including the following:
 - Record drawings of the original sanitary sewer and recent capital improvement projects to the existing, or near, the sanitary sewer.
 - Flow data (recent field data or collection system model results).
 - Utility information from existing records.
 - Condition assessment reports, including Closed Circuit Television (CCTV).
 - Maintenance and repair records of the original sanitary sewer, work orders, O&M records, scheduled repair, and/or replacement work, and emergency repairs.
 - Geographical Information System (GIS) data, including aerial and contour mapping.
 - Existing geotechnical information, including reports and studies.
 - Ground water elevation in NPSSI vicinity.
 - Engineering standards including standard specifications, details, and drawings.
 - Existing boundary mapping including right-of-way, utility easements, property lines, and property owner information within the corridor.
 - Interview maintenance staff.
- Consultant assumes that the City will provide the relevant data in City's possession relating to Consultant's services on the Project. Consultant will reasonably rely upon the accuracy, timeliness, and completeness of the information provided by City.

Subtask 1.2: Kickoff Meeting and Site Visit

- Kickoff Meeting. Consultant will conduct a kickoff meeting with the City of Casper Public Services Department Engineering Division and Public Utilities Division (and other representatives of departments, local agencies, and stakeholders of the projects) to discuss available data, roles, and

responsibilities; collaborative approach to complete the design; schedule and milestone dates; and proposed approach to the pre-design analysis. Because of current health orders, and for the safety of staff involved, this meeting could be conducted via teleconference platform (Skype, Microsoft Teams, etc.). A meeting summary will be prepared following the kickoff meeting.

- Site Visit. Consultant's team will complete a site visit of the NPSSI alignment to better understand the land features, potential access, surface features, and site constraints.

Subtask 1.3: Field Services

- Geotechnical. It is assumed that existing geotechnical data may be lacking to assess the high-water table in the pipeline repair segment vicinity. This information may be needed to assist in determining the optimal rehabilitation method as groundwater may impact the design and constructability. We have included a cost allowance for supplemental borings in the scope at pipe launching pits for slip line repair methods. Plans for control and discharge of groundwater must be ascertained during design to proactively address in construction documents and to avoid costly change orders.
- Supplemental Condition Assessment. Given that the field data used in the North Platte Sanitary Sewer Interceptor Condition Assessment Study (CH2M HILL/Jacobs April 2012) is approximately 8 to 10 years old, it is recommended that the pipe segments that were found to be likely rehabilitation candidates be reassessed as conditions can and do change over time. The goal of the condition assessment is to confirm the condition of the likely rehabilitation candidate segments, reprioritize segments as required, and provide the design team and the City additional insight in the selection process to properly select the optimal technology for design. Up to 8,700 feet of CCTV and condition assessment is included in the scope. To assist in the visual interpretation of the CCTV data, the interior crown of the pipe will be sprayed with water to remove the majority of the debris and decomposed concrete material (believed to be primarily calcium sulfate). The debris will not be removed from the pipeline.
- Surveying. Once the rehabilitation areas have been defined, and depending on existing data, surveying will need to be performed to confirm manhole rim and invert in/out elevations, slopes, and hydraulic grade data of the existing NPSSI alignment in areas to be rehabilitated. Drone photogrammetry can be employed to survey ground elevations in areas that need excavation to re-establish existing grades following construction. Survey information will be incorporated into the design documents.

Task 1.4: Project Scope Confirmation

- The outcome of Task 1 is to define the project scope in terms of which segments of interceptor, manholes, and drop connection improvements are to be included in the project. In the 2012 condition assessment study, the high priority (Priority 1) interceptor segments (noted in red in Exhibit 1) were included in the recommended capital improvement project along with cost-competitive Priority 2 segments (noted in yellow in Exhibit 1). Certain Priority 2 segments may be more cost-competitive due to the fact that they are located between Priority 1 segments, are believed to be more likely to become Priority 1 segments, or share what could be cost-effective staging areas. Once the project definition is completed, the review of technical alternatives can proceed in Task 2.
- The three drop manhole sidestream flow connection improvements identified in the 2012 study were recommended to reduce the release of hydrogen sulfide from the liquid phase to the vapor phase where microbially induced corrosion can occur. The three locations will be confirmed for inclusion in the project.

Task 1 Deliverables :

- Draft and Final Meeting Notes from Kickoff Meeting in pdf format.

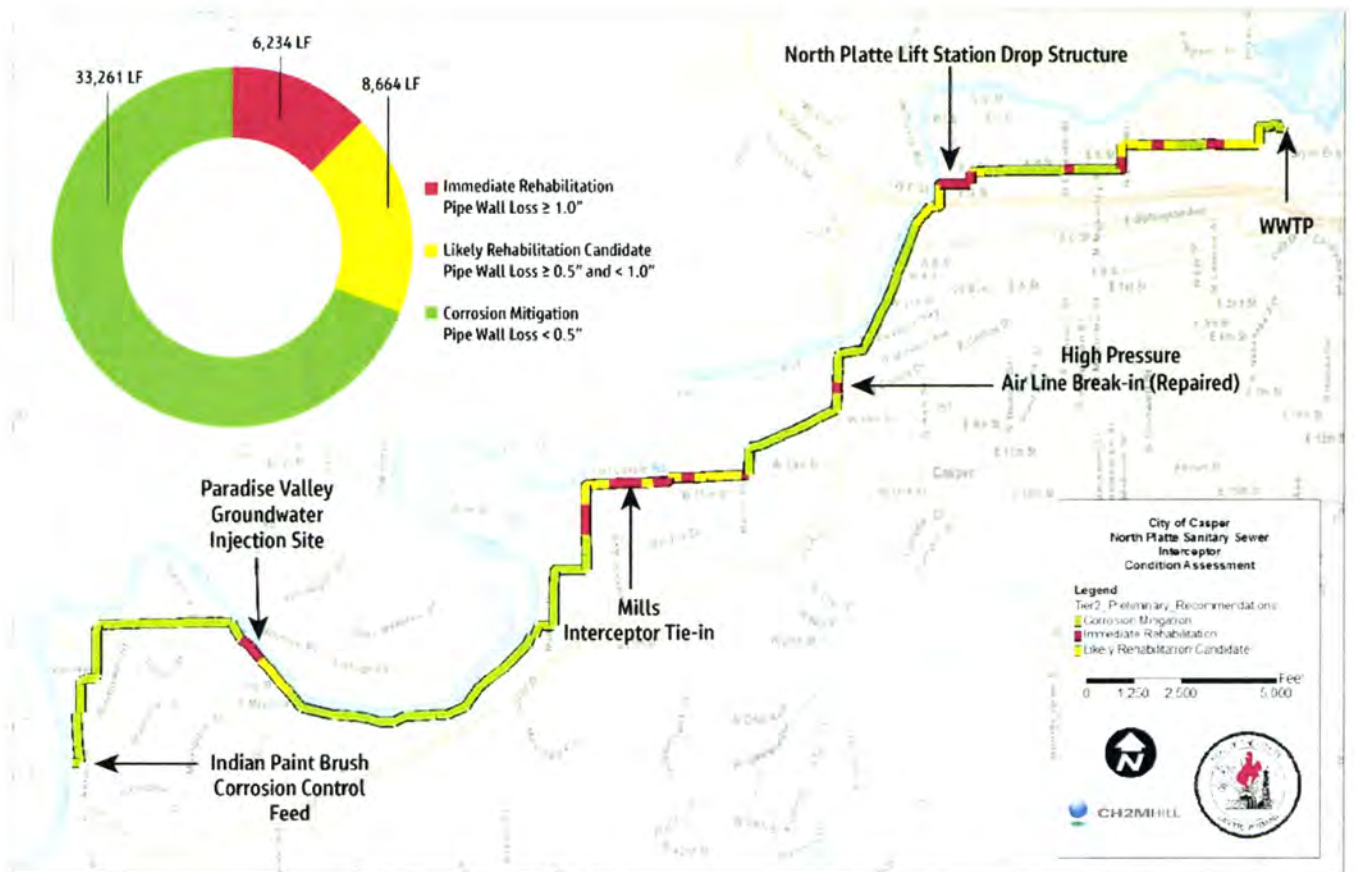

COC_SS_104_DEN

Exhibit 1. General Condition of the Interceptor from the 2012 NPSSI Condition Assessment Study

Task 2: Pre-Design Analysis (10 percent Design)

- Based on the fact that the City has completed the Clean Water State Revolving Fund (CWSRF) loan agreement with the State of Wyoming, it is assumed that the Environmental Assessment (EA) has been completed and a Categorical Exclusion (CatEx) or Finding of No Significant Impact (FONSI) has been issued. This assumption is based on conversations with Bill Tillman and Stan Miller with Wyoming Department of Environmental Quality (WDEQ); Mr. Miller stated that the EA had to be completed prior to approval of the loan agreement.
- Perform a pre-design review of three selected trenchless renovation technologies, as well as a conventional replacement project, as listed below:
 - Sliplining with pipe such as Fiberglass Reinforced Plastic (FRP)
 - Lining with Cured In Place Pipe
 - Geopolymer spray lining
 - Conventional excavation and replacement

This evaluation is necessary to review the effect of (1) hydraulic analysis and change in flow capacity, (2) new CCTV data if performed as optional task, and (3) lifecycle and construction costs of rehabilitation/replacement options on the selection of permissible technologies for bidding.

The Consultant's team previously discussed and presented two of the above trenchless technologies – sliplining and CIPP lining – for consideration in the 2012 study. Since the last comprehensive report of the NPSSI, there has been significant advancement and application of other systems, such as geopolymer relining applications. Our design team will explore geopolymer systems (not to be confused with cementitious lining systems), in particular, for the portion of the NPSSI that will be rehabilitated as it can be applied in different ways, provides a highly structural liner that meets the demands of the project, works well with determined concrete pipeline of irregular surfaces, and can be applied to both the pipeline and manhole systems resulting in a fully monolithic system.

- Perform a pre-design review of up to four manhole rehabilitation or replacement options, including:
 - Fiberglass fully-structural inserts
 - Replacement with corrosion resistant concrete additives
 - Sprayed on liners (e.g., SpectraShield)
 - Replacement with polymer-based matrix material (e.g., Rockhard SCP)
- Following review of the design criteria and assumptions for the sewer and possible manhole rehabilitation, evaluate the specific requirements and impacts of the rehabilitation along the sewer alignment, including:
 - Hydraulic capacity
 - Sewer cleaning performed as part of the rehabilitation work
 - Bypass pumping and piping
 - Construction access
 - Trenchless pipeline rehabilitation option specifics
 - Manhole rehabilitation option specifics
 - Connections that require rehabilitation
- Evaluate impacts and potential controls and management associated with temporary bypass piping, odor, noise, traffic and pedestrian movement, inclement and cold weather, etc.
- Confirm adequacy of existing rights-of-way and easements for trenchless technology rehabilitation and bypass pumping routing. Determine whether any temporary easements will be required for the pipe sections and proposed bypass pumping route.
- Provide property owner easement acquisition, including preparation of legal descriptions and temporary easement documents, for the expected relatively few required new easements.
- Evaluate City and County permitting and zoning constraints.
- Determine potential utility or other conflicts that could affect the pipe rehabilitation process.
 - Develop bidding strategy for having base bid for most critical segments with additive bid alternates to include as many pipeline segments as the City's budget will allow.
- Conduct a Pre-design Analysis Workshop with the City of Casper Public Services Department Engineering Division and Public Utilities Division.
- Participate in the City-led public meeting for the CWSRF loan process.
- Perform a Cost Effectiveness Analysis (CEA) for the CWSRF loan process.
- The Consultant's team will assist the City, who will take the lead, with organizing up to three neighborhood meetings to inform and educate residential and commercial customers about the upcoming construction including impacts and mitigation of impacts, including:
 - Traffic pattern modifications

- Access issues
- Odor and noise potential
- Service continuation

Task 2 Deliverables :

- Draft and Final Meeting Notes from Pre-Design Workshop in pdf format.
- Draft and Final Pre-Design Criteria Memo in pdf format.

Task 3.0: 50 Percent Design Phase

- Prepare a 50 percent plan set of construction documents for review by the City.
 - Design and lay out the rehabilitation procedures required for the existing sewer for the selected technology(s) determined during the pre-design analysis workshop.
 - Prepare plan and profile sheets that indicate the limits of manhole and sewer pipe rehabilitation, location of proposed manholes (if any), location and size of sanitary sewers connecting to the interceptor, location and details of bypass pumping systems, and location and details of temporary bypass piping network/manifolds, as required. The sheets will include survey data of manhole rim and bottom elevations, pipe diameter and flow lines of pipes entering and exiting manholes, and existing utility (water, sewer, gas, electrical, communication, etc.) information provided by the City of Casper Public Services Department and other agencies.
 - Complete the design using the City of Casper Public Services Department Engineering Division global specifications and supplement with additional technical specifications and project specific details, as required.
- Submit documents to the City of Casper Public Services Department for review.
- Conduct a 50 percent design package review workshop with the City and selected stakeholders.
- Prepare opinion of probable cost estimate following American Association of Cost Estimators (AACE) standard for Class 3 estimate.
- Prepare Traffic Control Plans and technical specifications for the anticipated phasing and sequencing of the project (separate Traffic Control Plans dependent on rehabilitation techniques and associated surface disturbances). The intent of the Traffic Control Plans is to: (1) identify viable detour routes, (2) develop prototype Traffic Control Plans, and (3) establish traffic control minimum requirements. The Contractor will be responsible for developing their own Traffic Control Plans that meet the requirements set forth on the drawings and in the technical specifications.

Task 3 Deliverables:

- Draft and Final Meeting Notes from 50 Percent Design Workshop in pdf format.
- Fifth percent construction documents (plans and specifications) in pdf format.
- Cost opinion based on the 50 percent construction documents.

Task 4.0: 90 Percent Design Phase

- Prepare a 90 percent set of construction documents for review. Comments from the 50 percent documents will be incorporated into the set. The set will include finalization of the limits of manhole and sewer pipe rehabilitation, location of proposed manholes (if any), location and size of sanitary sewers connecting to the interceptor, location and details of bypass pumping systems,

and location and details of temporary bypass piping network/manifolds, references to details, final general notes, and construction sequencing.

- Finalize Traffic Control Plans and technical specifications detailing measures to be implemented by the Contractor during construction.
- Prepare general provisions and division zero specifications, including incorporation of CWSRF loan program required boilerplate bidding documents.
- Submit drawings and specifications for review.
- Conduct 90 percent design package review workshop.

Task 4 Deliverables:

- Draft and Final Meeting Notes from 90 Percent Design Workshop in pdf format.
- Ninety percent construction documents (plans and specifications) in pdf format.

Task 5: 100 Percent Design Phase

- Final Documents. Upon receiving comments from the 90 percent submittal, prepare the final submittal of the construction documents for bidding.
- Bid Table. Prepare bid table based on unit price measurement payment schedule and use as a template for the opinion of probable construction cost.
- Opinions of Probable Construction Cost. Prepare engineer's opinion of probable construction cost. In providing opinions of cost, financial analyses, economic feasibility projections, and schedules for the project, Consultant has no control over cost or price of labor and materials; unknown or latent conditions of existing equipment or structures that may affect operation or maintenance costs; competitive bidding procedures and market conditions; time or quality of performance by operating personnel or third parties; and other economic and operational factors that may materially affect the ultimate Project cost or schedule. Therefore, Consultant makes no warranty that the City's actual project costs, financial aspects, economic feasibility, or schedules will not vary from Consultant's opinions, analyses, projections, or estimates. Cost estimate will be prepared in accordance with AACE Class 2 requirements.
- WDEQ Permit to Construct. Prepare application for Permit to Construct, including engineering report to meet requirements in Chapter 11 of the WDEQ's Rules and Regulations. CWSRF rules dictate that the Permit to Construct must be completed prior to advertising for bids, although if the review can be completed concurrently with bidding, this would save time in the schedule. We propose to discuss the possibility with WDEQ and the CWSRF Project Manager.

Task 5 Deliverables:

- 100 percent construction documents (plans and specifications) in pdf format.
- Cost opinion based on the 100 percent construction documents
- Draft and final WDEQ Permit to Construct Application

Task 6: Bid Phase Services

Consultant will provide services to assist the City in selection of a single Contractor for the construction of the project. These services will consist of the following.

Subtask 6.1: Project Advertisement

The City will advertise the bid per City requirements. The City will use its standard electronic bid procedures to distribute bid documents and bid addenda. Depending on the final technologies selected, prequalification of General Contractors may be warranted. Consultant can develop a prequalification questionnaire to screen qualified contractors prior to bidding.

Subtask 6.2: Response to Bidder Questions

The City shall be identified on the Contract Documents as the point of contact for bidder's questions during the bid period. The Consultant shall respond to Contractor questions as directed by the City. It is assumed that the bid period will be a maximum of 4 weeks. Consultant will provide technical interpretation of the construction documents and prepare proposed responses to bidders' questions and requests, which will be in the form of addenda.

Subtask 6.3: Pre-Bid Conference

Consultant will assist the City in arranging and conducting one pre-bid conference. Consultant will assist the City in developing the agenda and content of the pre-bid conference. Consultant will take notes and make provision for documenting the results of the pre-bid conference. Consultant will also record questions and requests for additional information, and shall coordinate with the City for issuing responses and additional information. Up to two Consultant staff members and up to two Subconsultant staff members shall attend the pre-bid meeting.

Subtask 6.4: Addenda

During the bid period, the Consultant shall assist the City with development of addenda and provide input to the City via email for the City to compile and post to plan holders. Addenda shall be reviewed and approved by the City prior to finalization and issuance to the bidders.

Subtask 6.5: Bid Review and Award

The City will conduct the bid opening for the project. Following the bid opening, if requested by the City, the Consultant shall assist the City with the review and evaluation of the bid results. This review will consist of reviewing the bids for irregularities, contacting references, and review of Contractor's qualifications.

This scope of services does not include engineering services that may be required in the event of a bid protest, or that might become necessary if the bids are significantly above the City's project budget, potentially requiring value engineering by the Consultant and negotiations with the selected Contractor to reduce the project cost.

The City will make the final decision on the award of the contract for construction and the acceptance or rejection of all bids.

The City will prepare the notice of award; assembly, delivery and execution of the contract for construction; and preparation of the notice to proceed. The City will sign the notice of award and the notice to proceed. Consultant will also provide reasonable assistance with negotiations with the selected bidder prior to execution of the contract for construction. The bidding documents will not be conformed to include changes issued by addenda during the bid period.

Task 6 Deliverables:

- Draft and Final Meeting Notes from pre-bid conference in pdf format.
- Draft and final bid addenda in pdf format.

Task 7.0: Engineering Services During Construction (SDC)

Consultant will provide SDC as defined below. These SDC are intended to assist the City in administering the contract for construction, periodically monitor the performance of the construction Contractor with the contract documents, and assist the City in responding to events that occur during the construction. These SDC are based upon the understanding that the City will contract directly with the Contractor and will be actively involved in the construction process to make decisions, provide approvals, and perform other actions necessary for the completion of the construction. Consultant will perform submittal review, respond to requests for information, and perform limited construction observations. These SDC are also based upon the City executing a contract for construction with the Contractor that is consistent with the Consultant's Agreement and with these SDC. Consultant will not be responsible for the means, methods, techniques, sequences, or procedures of the Contractor, nor will Consultant be responsible for the Contractor's failure to perform in accordance with the contract documents. Should Consultant discover or believe that any work by the Contractor is not in accordance with the contract for construction, or is otherwise defective, or not conforming to requirements of the contract or applicable rules and regulations, the Consultant will bring this to the attention of the City for further action.

- Consultant will conduct a pre-construction conference prior to the commencement of construction. The Consultant Project Manager and Design Manager will attend the conference, along with the resident project representative (RPR) from CEPI.
- Resident Project Representative. Conduct daily onsite observations of the Contractor's work to determine that it conforms to the Contract Documents and that the integrity of the design concept as reflected in the contract for construction has been implemented and preserved by the Contractor. Provide full-time RPR services at 45 hours per week for the estimated construction duration. Provide daily reports to the City of Casper Public Services Department Engineering Division summarizing the work, equipment, and staff provided by the Contractor before noon the following day.
 - Consultant will consult with, advise, and act as the City's project representative throughout the course of the project. Meetings will be held weekly during the construction phase, or more frequently as the work may require. Attendees will include City staff, RPR, CEPI construction lead, Consultant Design Manager and Project Manager (by phone, with Project Manager attending in person monthly), Contractor and subcontractors, and others as deemed necessary. Minutes will be recorded and maintained by CEPI.
 - A pre-construction conference will be held with the City, successful bidder, affected utilities, and other interested parties as deemed necessary by the City. Five copies of the Contract Documents will be provided at this meeting to the successful bidder.
 - Consultant will perform site visits and observe construction activities as necessary to obtain an accurate understanding of the progress and quality of work. Larry Trout of CEPI will act as the RPR during construction and will be on site during construction activities.
 - Daily logs of work activities will be maintained in electronic format and will include an appropriate number of well annotated photographs to aid in the effectiveness of the daily logs as a construction diary.
 - Construction progress photos and daily logs will be provided to the City on a monthly basis and as requested by City staff.
 - A correspondence file will be created to include memoranda, correspondence, meeting minutes, etc.

- Monthly progress reports will be created and submitted to the City. These reports will include major project information and an assessment of overall project progress with respect to the Contractor's submitted schedule, outstanding claims, and potential scope alterations.
- It is assumed that the limited construction staking for the project will be performed by the Contractor.
- Consultant will reject defective work if such work does not conform to the Contract Documents and design concept as defined in the Contract Documents.
- Materials testing will be provided under the construction contractor's contract.
- Consultant will act as the initial interpreter of the requirements of the Contract Documents and will judge the acceptability of the work as required by the RFP.
- Consultant will review tests, approval documents, and completion documents for completeness and compliance with Contract Documents. These documents will be transmitted to the City along with any comments.
- Walk-throughs will be performed to determine substantial completeness and final completeness. These walk-throughs will be scheduled so that City, Consultant, and Contractor personnel are present. Upon acceptance of final completion, final payment to the Contractor will be recommended in writing from Consultant to the City, in accordance with requirements and limitations as set forth in the RFP and Contract Documents.
- Record drawings will be completed based on information observed in the field, Contractor's documents, and survey data. These record drawings will be provided in the required formats and in accordance with standards set forth in the RFP and Contract Documents within 30 days of substantial completion. One half-size hard copy, one electronic PDF copy, and one electronic AutoCAD copy will be submitted to the City of Casper Public Services Division Engineering Department. CEPI will complete field record drawing surveys to confirm the elevation and location of constructed improvements and modify the design drawings to reflect the actual scope and locations of the completed improvements.
- Consultant will perform warranty period inspections at the prescribed intervals and shall include information and for purposes outlined in the RFP and Contract Documents.
- Limitation of Responsibilities. Unless otherwise provided for in this Contract, Consultant and its subcontractors shall not be responsible for the acts or omissions of any Contractor(s), or of any subcontractor or supplier, or any of the Contractor(s)' or subcontractor(s)' or supplier(s)' agents or employees or any other persons (except Jacobs and its subcontractor's employees and agents) at the site or otherwise furnishing or performing any of the Contractor(s)' work; however, nothing contained in paragraphs I.B.1 through I.B.17 (Construction Phase), inclusive shall be construed to release Consultant from liability for failure to properly perform duties and responsibilities assumed by Consultant in the Contract Document.
- Receive, review, and distribute certified payrolls.
- Perform labor audits as required by the SRF loan agreement.
- Verify conditions of the SRF loan agreement, e.g., certified payroll, labor interviews, buy American provisions, etc.
- Close-out Documentation. The RPR will assist the City of Casper Public Services Department Engineering Division in preparing punch-list items for substantial completion.

Office Engineering Services (Construction Management Support)

- **Payment Requests.** Receive and review the Contractor's monthly requests for payment. RPR will determine whether the amount requested reflects the progress of the Contractor's work and is in accordance with the Contract Documents for construction. Provide recommendations to the City of Casper Public Services Department Engineering Division as to the acceptability of the requests. Advise as to the status of the total amounts requested, paid, and remaining to be paid under the terms of the contract for construction. Pay applications will be signed by RPR and the City of Casper Public Services Department Engineering Division.
- **Submittal Review:** For the purposes of estimating the level of effort for this task, Consultant has assumed 25 percent resubmittals and 190 total hours of review time.
 - **Submittal Schedule.** Obtain from the City of Casper Public Services Department Engineering Division through the Contractor a proposed shop drawing and submittal schedule, which will identify shop drawings, samples and submittals required by the contract for construction, along with the anticipated dates for submission.
- **Review of Shop Drawings, Samples, Substitutions, and Submittals.** Coordinate with the design team for the reviews of the Contractor's shop drawings, samples, O&M manuals, and other submittals. Log and track shop drawings, samples, and submittals. The design team's review of shop drawings, samples, and submittals will be for general conformance with the design concept and general compliance with the requirements of the contract for construction. Such review shall not relieve the Contractor from its responsibility for performance in accordance with the contract for construction, nor is such review a guarantee that the work covered by the shop drawings, samples and submittals is free of errors, inconsistencies, or omissions.
- **Interpretations of Contract Documents:** For the purposes of estimating the level of engineering effort a budget of 146 total hours was established for this task.
 - **Requests for Information.** Review the Contractor's requests for information or clarification or proposed substitution of materials and/or equipment. Coordinate such review with the design team and the City of Casper Public Services Department Engineering Division as appropriate and as to the acceptability of such substitutions. Coordinate and issue responses to the requests to the Contractor.
 - **Field Orders.** Assist with the determination of minor variations in the work that do not involve an adjustment in the Contractor's contract price nor time for construction and that are consistent with the intent of the Contract Documents. Prepare field orders as appropriate with the City of Casper Public Services Department Engineering Division and CWSRF authorization.
- **Change Orders.** Consultant will receive changes and issue changes to the contract for construction from the Contractor. At the City of Casper Public Services Department Engineering Division request, review the changes and provide input to the change. The City of Casper Public Services Department Engineering Division will negotiate changes with the Contractor. Track issued change orders, pending change orders, and change order amounts. For the purposes of estimating the level of engineering effort a budget of 140 total hours was established for this task.

- **Final Inspection.** One member of the Consultant's staff and Subconsultant's staff will participate in a final inspection with the City and Contractor to review the work and document items for correction that will be noted on the punch list.
- **Record Drawings.** At the completion of construction work, Consultant and Subconsultant will review and comment on record drawing information supplied by the Contractor and will incorporate information on the drawings. It is assumed that the Contractor will provide a consolidated set of as-builts including changes, and clarifications issued during construction. Consultant will prepare electronic record drawings (PDF and AutoCAD format only, no hard copies required) for the City. Consultant is not responsible for any errors or omissions in the information from others that are incorporated into the record drawings.
- **Warranty Service.** Warranty service will be provided to assist with Contractor warranty work requests. For the purposes of estimating the level of engineering effort a budget of 88 total hours was established for this task.

Task 7 Deliverables:

- Project meeting agendas and minutes.
- Communications with Contractor and City.
- Field inspection reports and photos.
- Project close out documentation.
- Record drawings in AutoCAD format.

Task 8: Project Management

The Consultant will provide the following project management and administration subtasks to support the engineering services.

Task 8.1: Project Execution Plan and Setup

The Consultant will prepare a brief Project Execution Plan (PXP) to serve as a guide for the project team. The PXP will outline procedures, summarize project goals and scope, present the project work plan (which will include tasks, staff assignments, level of effort, costs, and schedule), and include other information that is pertinent to the successful execution of the project. The PXP will serve as a guide to the Consultant's project team during the course of the project.

Task 8.2: Project Management

Consultant's Project Manager (PM) shall prepare, implement, monitor, and update the PXP throughout the project. Consultant's PM will prepare and submit to the City's PM, on a monthly basis, a brief cost and status report.

Task 8.3: Health and Safety

The Consultant will develop a Health and Safety Plan for the project that will be followed by Consultant staff and Subconsultants.

Task 8 Deliverables:

- Monthly invoices and progress reports.

Project Schedule

Consultant has prepared a schedule that meets the requirements of the project including:

- Four-phase design delivery from 10 percent, 50 percent, 90 percent, and final design deliverable
- Workshop progress review meetings following each key deliverable
- WDEQ Review and Approval and Permit to Construct approval must be completed prior to start of bid phase

Guidance documents from WDEQ indicate that up to a 60-calendar day period be allowed for review period. The proposed schedule is what we believe is reasonable for a project of this complexity. Exhibit 2 is our proposed schedule for the project.

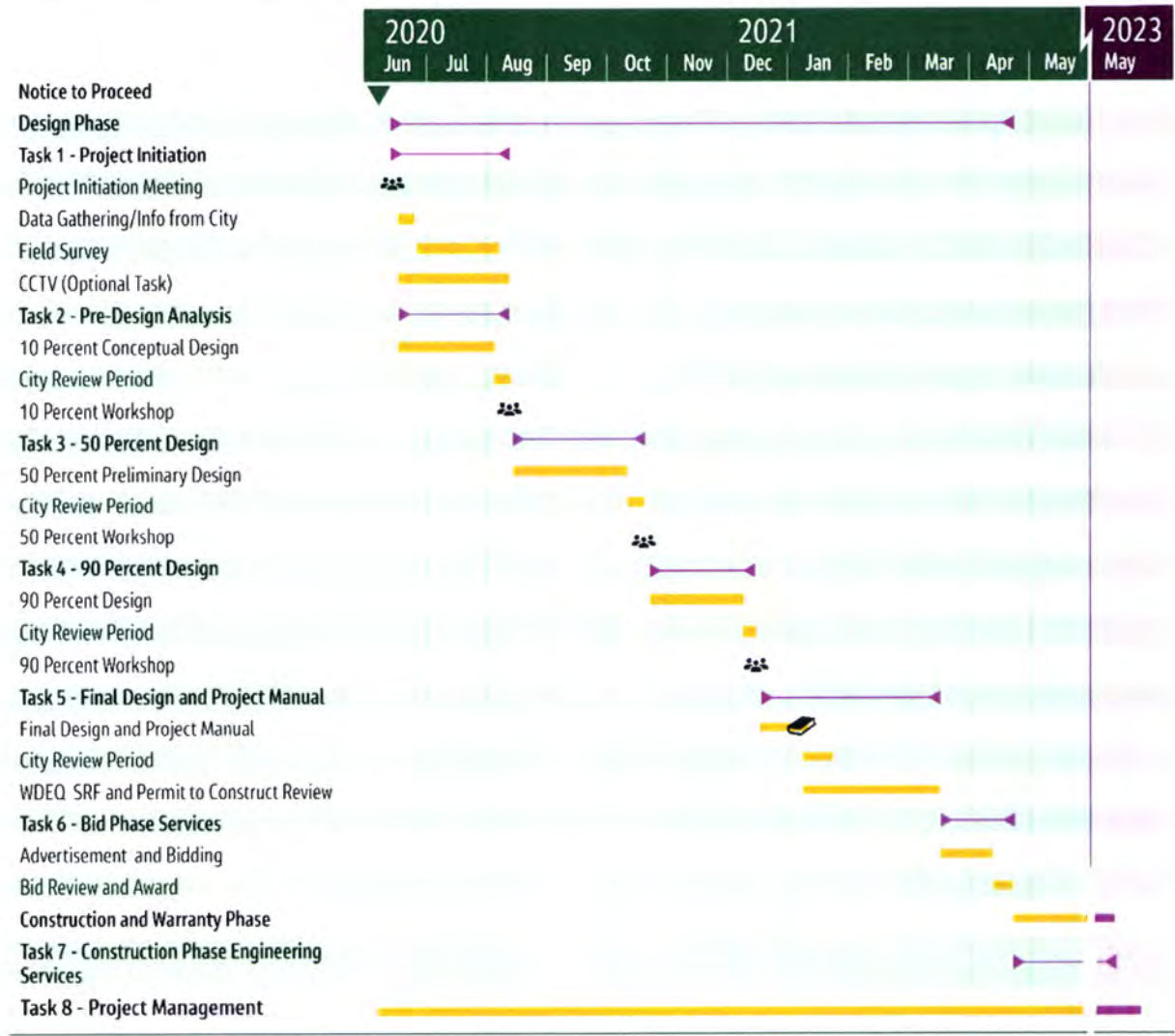

COC_SS_105_DEF

Exhibit 2. Project Schedule

Compensation

Compensation to Consultant will be on the basis of Time and Expense in accordance with the Fee Schedule, Exhibit B. Refer to Exhibit B which includes the total not to exceed compensation for the Scope of Work. The estimated cost and assumed level of effort is provided for each task. The Consultant will make reasonable efforts to complete the work within this budget and will keep the City informed of progress toward that end so that the budget or work effort can be adjusted if found necessary and agreed to by the City. Consultant will manage the budget based on the total contract limit and will not exceed that budget without written approval from the client. Individual task budgets may be exceeded during delivery of the project, however these changes will be managed and communicated to the client. Expenses will be billed at actual cost and will include travel, printing, mailing, copying, supplies, and other similar costs incurred in performance of the work. Invoices from Subconsultants will be marked up 5 percent.

EXHIBIT "B"

Detailed Fee Proposal - Engineering Design Services for the North Platte Sanitary Sewer Rehabilitation

Task Description	Jacobs																				BlueWater			CEPI				Labor Hours	Labor	BlueWater and CEPI Expense ⁽²⁾	Jacobs Expense	Total
	Kyle Snider, Project Manager	Doug Jenkins, Design Manager	Raquel Blue, Design Engineer	Dan Hegwald, Field Services Lead	Dan Buonadonna, Senior Technical Consultant	Hegwald Staff	Hegwald Staff	Kessia Diaz, CAD	Janelle Prange, Staff Engineer	Ed Meyer, Cost Estimator	Mike Petersen, Health & Safety	Kathleen Malin, Specifications	Sandy Orren, Office/Administration	Mark Wade, Senior Technical Consultant	Tom Brauer, Project Advisor/Construction Lead	Nick Larson, Hydraulic Modeller	Ray Catellier, Design Lead	Karson Burnett, Design Engineer	Brian DeTuits, CAD	Larry Trout, RPR	Administrative, Secretarial	Survey Crew	Bill Fehring, Survey Manager									
2020 Rate ¹	\$240.00	\$240.00	\$185.00	\$220.00	\$210.00	\$175.00	\$150.00	\$115.00	\$115.00	\$240.00	\$175.00	\$140.00	\$95.00	\$213.70	\$150.00	\$150.00	\$130.00	\$125.00	\$105.00	\$90.00	\$55.00	\$165.00	\$120.00									
Task 1 - Project Initiation	22	50	56	0	0	0	0	0	8	0	0	0	0	34	13	6	13	20	20	0	0	50	30	322	\$56,816	\$12,731	\$3,010	\$72,557				
1.1 Existing Document Review	4	16	16	0	0	0	0	0	8	0	0	0	0	16	5	2	5							72		\$308						
1.2 Kickoff Meeting Site Visit	16	16	16	0	0	0	0	0	0	0	0	0	0	16	8	4	8							84		\$995	\$3,010					
1.3 Field Services (allowances/supplements)																																
1.3.1 Geotechnical Allowance	1	16	16	0	0	0	0							2										35	\$7,467	\$21	\$15,000	\$22,489				
1.3.2 Supplemental Condition Assessment	1	8	16	8	4	100	100							32			40							349	\$57,858	\$882	\$30,500	\$89,240				
1.3.3 Supplemental Flow Monitoring (not in scope)	0	0	0	0	0	0	0							0		0	0							0	\$0	\$0	\$0	\$0				
1.3.4 Survey	1	2	8	0	0	0	0							0			20	20				50	30	131		\$11,428						
Task 2 - Pre-Design Analysis (10%)	14	38	48	0	8	0	0	40	36	0	0	0	4	40	21	9	29	20	0	0	0	0	307	\$51,478	\$1,648	\$1,410	\$54,536					
2.1 Trenchless Alternative Selection	3	10	20	4	4			320	60	30	0	40	16	48	40	24	24	80	10	0	0	0	0	90		\$278						
2.2 Pre-Design Criteria Memo	3	20	24	4				40	16			2	8	8		20	20							165		\$400						
2.3 Pre-Design Workshop	8	8	4									0	16	8	4	4	0							52		\$969	\$1,410					
Task 3 -50 Percent Design Phase	24	88	100	0	4	0	0	320	60	30	0	40	16	48	40	24	24	80	10	0	0	0	908	\$138,268	\$3,854	\$1,410	\$143,531					
3.1 50% Plan and Specifications	20	80	100	0	4	0	0	320	60	30	0	40	16	32	34	20	20	80	10					866		\$2,899						
3.2 50% Workshop	4	8	4	0	0	0	0	0	0	0	0	0	0	16	6	4	4							42		\$954	\$1,410					
3.3 Supplemental Dual Solutions Design	4	16	32	2	2			32	24	1		8		10		10	40							179	\$26,740	\$390		\$27,130				
Task 4 -90 Percent Design Phase	32	48	84	0	4	0	0	170	44	20	0	56	18	32	20	0	54	74	30	0	0	0	686	\$103,798	\$2,145	\$365	\$106,309					
4.1 90% Plan and Specifications	24	40	80	0	4	0	0	170	40	20	0	56	16	16	14		50	70	30					630		\$1,196						
4.2 90% Workshop	8	8	4	0	0	0	0	0	4	0	0	0	2	16	6	4	4							56		\$949	\$365					
4.3 Supplemental Dual Solutions Design	4	16	20	2	2			24	24	1		8		10		10	40							159	\$23,600	\$390		\$23,990				
Task 5 -Final Design Phase	32	44	72	0	2	0	0	88	40	10	0	32	16	8	28	10	20	20	20	0	0	0	442	\$69,710	\$730		\$70,440					
5.1 100% Plan and Specifications	16	20	40	0	2	0	0	80	20	10	0	32	16	8	14		20	20	20					318		\$550						
5.2 WDEQ Permit to Construct	16	24	32	0	0	0	0	8	20	0	0	0	0	0	14	10								124		\$180						
5.3 Supplemental Dual Solutions Design	4	8	16	2	2			8	24	1		8		10		10	40							131	\$19,100	\$390		\$19,490				
Task 6 - Bid Phase Services	17	48	41	0	0	0	0	0	24	0	0	0	6	14	16	0	16	6	0	0	0	0	188	\$34,737	\$411		\$35,148					
6.1 Advertisement	1	2	1	0	0	0	0	0	0	0	0	0	0	0	1		1	0						6		\$14						
6.2 Response to Bidder Questions	1	16	16	0	0	0	0	0	12	0	0	0	2	6	5		5	3						66		\$153						
6.3 Pre-bid Conference	12	12	4	0	0	0	0	0	0	0	0	0	2	4	5		5	0						44		\$113	\$1,410					
6.4 Addenda	1	16	16	0	0	0	0	0	12	0	0	0	2	2	5		5	3						62		\$110						
6.5 Bid Review and Award	2	2	4	0	0	0	0	0	0	0	0	0	0	2										10		\$21						
Task 7 - Services During Construction	202	184	144	0	0	0	0	40	152	0	0	0	0	88	166	0	118	40	20	1,830	0	80	3,074	\$386,606	\$30,382	\$4,940	\$421,927					
7.1 - Meetings	56	68	0	0	0	0	0	0	0	0	0	0	0	28	48	0	24	10	0	10	0	0	0	244	\$48,214	\$1,605	\$1,410	\$49,819				
7.1.1 Pre-Construction Conference	16	16												4	8		4	0		10				58		\$174	\$1,410					
7.1.2 Progress Meetings	40	52												24	40		20	10						186		\$1,431						
7.2 - Submittal Review	8	32	40	0	0	0	0	0	40	0	0	0	0	10	10		10	20		20				190		\$462						
7.3 - RFIs and Change Orders	16	40	80	0	0	0	0	0	80	0	0	0	0	20	20	0	20	10	0	0	0	0	0	286		\$556						
7.3.1 Requests for Information	8	20	40						40					8	10		10	10						146		\$288						
7.3.2 Change Orders	8	20	40						40					12	10		10							140		\$268						
7.4. Construction Observations	120	40	16	0	0	0	0	0	16	0	0	0	0	28	78	0	54	0	0	1,800	0	0	0	2,152	\$229,904	\$24,672	\$3,530	\$254,576				
7.4.1 Design Team Site Visits	96	16												12	60		40							224		\$7,453	\$2,920					
7.4.2 Resident Project Representative																				1,800				1,800		\$15,772						
7.4.3 Final Inspection	8	8							0					12	8		4							40		\$1,264	\$610					
7.4.4 Warranty Service	16	16	16						16					4	10		10							88		\$183						
7.5 - Record Drawings	2	4	8	0	0	0	0	40	16	0	0	0	0	2	10	0	10		20			80	10	202		\$3,086						
Task 8 - Project Management	204	24	8	0	0	0	0	0	2	0	20	0	44	0	1	0	1	0	0	2	0	0	306	\$64,570	\$0		\$64,570					
8.1 Project Execution Plan and Setup	40												20											60		\$0						
8.2 Project Management	160	20											20											200		\$0						
8.3 Health and Safety	4	4	8						2		20		4		1		1			2				46		\$23						
Project Total Including Supplemental Tasks	560	572	637	8	28	100	100	722	438	63	20	152	104	296	335	79	315	420	100	1,832	0	130	7,051	\$ 1,033,280	\$ 53,954	\$ 41,635	\$ 1,128,870					

¹ Hourly rates are valid June 2020 through May 2023.

² Expenses include 5% markup on CEPI and Blue Water invoices to Jacobs

Supplemental Services Notes:
The Supplemental Condition Assessment includes CCTV of 8,700 LF of interceptor.
The Supplemental Flow Monitoring will not be included in the project scope.
The Supplemental Dual Solutions Design includes plans and specifications for a having a second allowable rehabilitation technology for the bidders instead of just one.

RESOLUTION NO. 20-140

A RESOLUTION AUTHORIZING A CONTRACT FOR PROFESSIONAL SERVICES WITH JACOBS ENGINEERING GROUP, INC. FOR DESIGN AND CONSTRUCTION ADMINISTRATION FOR THE NORTH PLATTE SANITARY SEWER REHABILITATION PROJECT.

WHEREAS, the City of Casper desires to secure an engineering firm to provide design and construction administration services for the North Platte Sanitary Sewer Rehabilitation Project; and,

WHEREAS, Jacobs Engineering Group is able and willing to provide those professional services.

NOW, THEREFORE, BE IT RESOLVED BY THE GOVERNING BODY OF THE CITY OF CASPER, WYOMING: That the Mayor is hereby authorized and directed to execute, and the City Clerk to attest, a Contract for Professional Services with Jacobs Engineering Group, in the amount of One Million One Hundred Twenty-Eight Thousand Eight Hundred Seventy Dollars (\$1,128,870) for services more specifically delineated in the Contract.

BE IT FURTHER RESOLVED: That the City Manager is hereby authorized to make verified partial payments and contract extensions, using appropriate funds, throughout the project as prescribed by the Contract, for a total amount not to exceed One Million One Hundred Twenty-Eight Thousand Eight Hundred Seventy Dollars (\$1,128,870).

PASSED, APPROVED, AND ADOPTED this ____ day of _____, 2020.

APPROVED AS TO FORM:

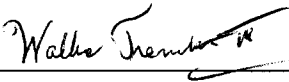

ATTEST:

Fleur Tremel
City Clerk

CITY OF CASPER, WYOMING
A Municipal Corporation

Steven K. Freel
Mayor

June 8, 2020

MEMO TO: J. Carter Napier, City Manager 

FROM: Andrew Beamer, P.E., Public Services Director 
Bruce Martin, Public Utilities Manager
Alex Sveda, P.E., Associate Engineer

SUBJECT: Authorizing Amendment No. 1 to a Grant from the Wyoming Water Development Commission for additional funds in the amount of \$643,000 for the CY Booster Station Replacement Project, No. 16-024.

Meeting Type & Date:

Regular Council Meeting
July 7, 2020

Action Type:

Resolution

Recommendation:

That Council, by resolution, authorize Amendment No. 1 to a Grant from the Wyoming Water Development Commission (WWDC) for additional funds in the amount of \$643,000 for the CY Booster Station Replacement Project, No. 16-024.

Summary:

The CY Booster Station was built in 1953 and provides water to Valley Hills and Sunrise I water storage tanks, serving approximately 8,000 residents in Zone II. The facility was expanded in 1981 which included new valve assemblies, fittings and piping. The existing pumps have been rebuilt several times and have been operating for over forty (40) years. Due to the age of the facility and equipment, a new booster station is being constructed with new pumps sized for future growth in Zone II.

In August 2017, a Grant was executed between WWDC and the City for \$852,910. Additional funds were requested by the City after the second bidding in February 2020, where the bids came in higher than expected due to additional work included in the bid to mitigate unsuitable existing soils for the new building foundation, mechanical equipment costs, electrical/SCADA (Systems Control and Data Acquisition), and Surge Control system costs. Amendment No. 1 to the Grant includes an additional \$643,000 of WWDC, for a Grant total in the amount of \$1,495,910.00.

In February 2020, construction of the project was awarded to High Plains Construction, Inc. in the amount of \$2,092,593. Work for the project has commenced and is ongoing with tentative completion scheduled for November 2020.

Financial Considerations:

With Amendment No. 1, construction improvements will be funded through 67% or \$1,254,760.59 of eligible reimbursable costs from the WWDC Grant. The 33% local match of will be obtained from FY18 Water Fund Reserves.

Oversight/Project Responsibility:

Alex Sveda, Associate Engineer

Attachments:

Resolution

Two Original Amendment No. 1 documents

**AMENDMENT ONE TO PROJECT AGREEMENT
CASPER CY BOOSTER STATION REPLACEMENT 2017 PROJECT**

1. **Parties.** This Amendment is made and entered into by and between the State of Wyoming, acting by and through the WYOMING WATER DEVELOPMENT COMMISSION (COMMISSION), whose address is: 6920 Yellowtail Road, Cheyenne, WY 82002 and CITY OF CASPER, Natrona County, Wyoming, a duly organized municipality existing under the laws of that state (SPONSOR), whose address is: City of Casper, 200 North David Street, Casper, WY 82601.
2. **Purpose of Amendment.** This Amendment shall constitute the first amendment to the Project Agreement between the COMMISSION and the SPONSOR. The purpose of this Amendment is to: a) supplement the PROJECT with funding from the Sponsor's Contingency Fund; and b) change the conditions for disbursing funds.

The original Project Agreement, dated August 15, 2017, was to implement the provisions of the 2017 Wyo. Sess. Laws, Ch. 75, authorizing the design, construction and operation of the Casper CY Booster Station Replacement 2017 Project.

3. **Term of the Amendment.** This Amendment shall commence upon the date the last required signature is affixed hereto (Effective Date), and shall remain in full force and effect through the term of this Project Agreement, as amended, unless terminated at an earlier date pursuant to the provisions of the Project Agreement, or pursuant to federal or state statute, rule or regulation.
4. **Amendments.**
 - A. **PROJECT Loan and Grant.** The PROJECT funding as set forth in Section 4.A. of the original Project Agreement is hereby amended to read as follows:

“4.A. The STATE OF WYOMING has appropriated from the Water Development Account created by Wyo. Stat. § 41-2-124 (a)(ii), to the COMMISSION, a sum not to exceed ONE MILLION FOUR HUNDRED NINETY-FIVE THOUSAND NINE HUNDRED TEN DOLLARS (\$1,495,910.00) which will be disbursed to the SPONSOR for the purpose of completing the aforementioned PROJECT. The funds are divided as follows:

- (1) A grant to the SPONSOR of not more than EIGHT HUNDRED FIFTY-TWO THOUSAND NINE HUNDRED TEN DOLLARS (\$852,910.00) or sixty-seven percent (67%) of the actual development costs, whichever is less until it is entirely disbursed, followed by:

- (2) A grant to the SPONSOR of not more than SIX HUNDRED FORTY-THREE THOUSAND DOLLARS (\$643,000.00) or sixty-seven percent (67%) of the additional funds needed to complete the PROJECT, whichever is less.”

5. **Special Provisions.**

- A. **Same Terms and Conditions.** With the exception of items explicitly delineated in this Amendment, all terms and conditions of the original Project Agreement between the COMMISSION and the SPONSOR, including but not limited to sovereign immunity, shall remain unchanged and in full force and effect.
- B. **Counterparts.** This Amendment may be executed in counterparts. Each counterpart, when executed and delivered, shall be deemed an original and all counterparts together shall constitute one and the same Amendment. Delivery by the SPONSOR of an originally signed counterpart of this Amendment by PDF shall be followed up immediately by delivery of the originally signed counterpart to the COMMISSION.
- C. **Return of Executed Amendment to Commission.** The SPONSOR shall not execute any agreements or incur any project costs that are covered under this Amendment until this Amendment is fully executed and returned to the COMMISSION.

6. **General Provisions.**

- A. **Entirety of Agreement.** The original Project Agreement, consisting of seven (7) pages and this Amendment One consisting of three (3) pages, represent the entire and integrated agreement between the parties and supersede all prior and contemporaneous negotiations, representations and agreements, whether written or oral.

THE REMAINDER OF THIS PAGE WAS INTENTIONALLY LEFT BLANK

- 7. **Signatures.** The parties to this Amendment, through their duly authorized representatives, have executed this Amendment on the dates set out below, and certify that they have read, understood, and agreed to the terms and conditions of this Amendment.

The Effective Date of this Amendment is the date of the signature last affixed to this page.

WYOMING WATER DEVELOPMENT COMMISSION

Michael R. Russell

 Chairman

5/15/20

 Date

[Signature]

 Secretary

5/15/20

 Date

CITY OF CASPER

 Steve Freel, Mayor

 Date

ATTORNEY GENERAL'S OFFICE: APPROVAL AS TO FORM

Aly Gold # 202547

 At: Tyler M. Benner, Assistant Attorney General

5/6/2020

 Date

APPROVAL AS TO FORM

I have reviewed Amendment One to Project Agreement Casper CY Booster Station Replacement 2017 Project and approve it as to form on behalf of the City of Casper, Wyoming.

Dated: June 9, 2020

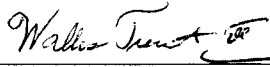

Wallace Trembath III
Deputy City Attorney

RESOLUTION NO. 20-141

A RESOLUTION AUTHORIZING ACCEPTANCE OF WWDC
AMENDMENT NO. 1 TO THE GRANT AGREEMENT FOR
THE CY BOOSTER STATION REPLACEMENT PROJECT.

WHEREAS, the City of Casper desires to replace a domestic water pump station serving pressure zone two (2) of the City's water system, otherwise known as the CY Booster Station; and,

WHEREAS, a Grant Agreement was executed between Wyoming Water Development Commission (WWDC) and the City of Casper on August 15, 2017 for the CY Booster Station Replacement Project in the amount of Eight Hundred Fifty-Two Thousand Nine Hundred Ten and 00/100 Dollars (\$852,910.00); and,

WHEREAS, the WWDC and the City of Casper wish to enact Amendment No. 1 in the amount of Six Hundred Forty-Three Thousand and 00/100 Dollars (\$643,000.00) to the Grant Agreement for construction of the CY Booster Station Replacement Project, for a total revised Grant Agreement of One Million Four Hundred Ninety-Five Thousand Nine Hundred Ten and 00/100 Dollars (\$1,495,910.00); and,

WHEREAS, the City of Casper accepts the conditions of Amendment No. 1 to the WWDC Grant Agreement that require the City of Casper to fund a 33% match of the Grant.

NOW, THEREFORE, BE IT RESOLVED BY THE GOVERNING BODY OF THE CITY OF CASPER, WYOMING: That the Mayor is hereby authorized and directed to execute, and the City Clerk to attest, a 67% Grant Agreement issued by the WWDC in the amount of One Million Four Hundred Ninety-Five Thousand Nine Hundred Ten and 00/100 Dollars (\$1,495,910.00) for the CY Booster Station Replacement Project.

PASSED APPROVED, AND ADOPTED this ____ day of _____, 2020.

APPROVED AS TO FORM:



ATTEST:

CITY OF CASPER, WYOMING
A Municipal Corporation

Fleur Tremel
City Clerk

Steven K. Freel
Mayor

June 10, 2020

MEMO TO: J. Carter Napier, City Manager 

FROM: Andrew Beamer, P.E., Public Services Director 

SUBJECT: Authorizing a License Agreement with Advanced Communications Technology, Inc., for Installation of Buried Fiber Optic Cable Infrastructure Within City Right-of-Way

Meeting Type & Date

Regular Council Meeting
July 7, 2020

Action Type

Resolution

Recommendation

That Council, by resolution, authorize a license agreement with Advanced Communications Technology, Inc., (ACT) to install buried fiber optic cable infrastructure within City right-of-way.

Summary

ACT requests the City's permission to install underground fiber optic cable infrastructure within City right-of-way. Installation will generally occur along Kimball St. at the intersection with East "C" Street, along Kimball Street to East "A" Street, along East "A" Street to Center Street, along Center Street to East 9th Street, along East 9th Street to Wolcott Street, and along Wolcott Street to the Casper College campus. Provisions in the license agreement call for ACT to be responsible for all costs associated with construction and maintenance of the facilities and appurtenances, and restoration of the property should the license agreement be revoked.

Financial Considerations

ACT is currently in the process of negotiating a franchise agreement with the City of Casper. Until that agreement is consummated, ACT will pay an annual fee Eleven Thousand Three Hundred Seventy-Five and 23/100 Dollars (\$11,375.23) per year for the use of the right-of-way.

Oversight/Project Responsibility

Andrew Beamer, P.E., Public Services Director

Attachments

Resolution
Revocable License Agreement

**REVOCABLE LICENSE AGREEMENT
FOR INSTALLATION OF BURIED FIBER OPTIC CABLE
INFRASTRUCTURE**

FOR AND IN CONSIDERATION OF THE SUM OF Eleven Thousand Three Hundred Seventy-Five and 23/100 Dollars (\$11,375.23) per year, being \$1.20 per lineal foot of cable installed per year, the sufficiency of which is hereby acknowledged, the CITY OF CASPER, WYOMING, 200 North David, Casper, Wyoming 82601, hereinafter called the "**Licensor**," HEREBY GRANTS A REVOCABLE LICENSE ("**License**") to ADVANCED COMMUNICATIONS TECHNOLOGY, INC. (ACT), 290 N. Brooks Street, Sheridan, Wyoming 82801, hereinafter called the "**Licensee**," to construct, alter, operate, maintain, inspect, repair, replace, and remove underground fiber optic cable infrastructure, hereinafter called the "**Facility**," located upon the following-described land situated in the City of Casper, County of Natrona, State of Wyoming, to-wit:

(See attached Exhibit "A" consisting of one (1) page, attached hereto and made a part of this Agreement)

THIS LICENSE is granted upon such express terms and conditions as are hereinafter set forth, and should the Licensee at any time violate any of the said terms and conditions, the Licensor, at its option, may immediately revoke this License; provided, however, Licensor first gives notice to Licensee of the alleged violation and provides to Licensee a reasonable opportunity to cure or rectify the alleged violation.

THIS LICENSE is subject to the following conditions:

1. Abandonment. If Licensee removes the Facility at any time for purposes other than maintenance or repair, this License shall be considered abandoned by the Licensee and automatically terminate.
2. Facility Condition. The work of constructing, altering, operating, maintaining, inspecting, repairing, replacing, or removing the Facility hereinabove referred to shall be prosecuted and completed in a good and workmanlike manner at the sole expense of the Licensee, and in accordance with good construction practice and the applicable City of Casper Standard Specifications. The Licensee's responsibility shall include, but not be limited to, restoring all surfaces to the same condition they were in prior to the maintenance authorized by this License. The Licensor reserves the right to, but need not, inspect such work in order to ensure compliance with said standards. Such work of maintenance, repair, or removal of the Facility shall be done in such a manner as to not unreasonably interfere with the use of the licensed premises by the Licensor and the general public and in such manner as to in no way endanger the general public in the use of said premises.

3. Title. Licensee hereby acknowledges the title of Licensor to the above described licensed premises, and agrees never to sell, resist, deny or encumber any such title.
4. Indemnification. Licensee agrees to indemnify the Licensor, its elected officials, appointed officials, employees, and duly authorized agents against, and save them harmless from, all liability for damages to property, or injury to, or death of, persons, including the Licensor, its agents and employees, and including all costs and expenses incident thereto arising wholly or in part from, or in conjunction with, existence, maintenance, repair, renewal, operation, use, or removal of the said Facility, to the extent such damage or injury is caused by the acts of Licensee, its agents or employees.
5. Insurance Requirements.
 - A. In order to ensure the ability of the Licensee to indemnify the City, the Licensee shall obtain, at its sole cost and expense, public liability insurance coverage in an amount no less than the City's maximum liability under the Wyoming Governmental Claims Act, W.S. 1-39-101 *et seq.*, currently Two Hundred Fifty Thousand Dollars (\$250,000) to any claimant for any number of claims arising out of a single transaction or occurrence, and Five Hundred Thousand Dollars (\$500,000) for all claims of all claimants arising out of a single transaction or occurrence.
 - B. Such insurance shall provide that it will not be cancelled or limits reduced without at least thirty (30) days prior written notification to the City, that the City is an additional named insured thereunder, and that it is primary insurance without any right of contribution from any other resource or insurance.
 - C. Licensee shall provide the City with certificates evidencing such insurance as described above immediately after execution of this License and prior to use of the licensed premises.
 - D. Licensee shall further provide the City with copies of its insurance policy and/or policy endorsements listing the City of Casper as an additional insured. The City's failure to request or review such policies, endorsements, and certificates shall not affect the City's rights or the Licensee's obligation hereunder.
 - E. It is recognized by and between the Parties to this License that the insurance requirements contained herein are the maximum liabilities which may be imposed under Wyoming Statute Section 1-39-101 *et seq.*
 - F. In the event the maximum liability allowed by law is altered, either during the initial Term of this License, then such insurance requirements as outlined above from the Licensee shall be amended accordingly so as to provide insurance in an amount equal to or greater than the maximum liability imposed by law.

- G. It is entirely the obligation of the Licensee to provide insurance for their personal property and for that of its participants, employees and agents.
6. Right of Use, Relocation, Revocation and Removal.
- A. The Licensor reserves the right to use, occupy, and enjoy the Facility in such a manner and at such times as it shall desire, the same as if this instrument had not been executed by them. If any such use shall, at any time, necessitate any change in the location or manner of use of said Facility, or any part thereof, such change or alteration shall be made by the Licensee within a reasonable time at the sole expense of said Licensee, upon the demand of the Licensor and the Licensor shall not be liable to said Licensee on-account thereof, or on account of any damage growing out of any use which the Licensor may make of its Facility.
 - B. In addition to its right to revoke this License for cause, the Licensor shall have the right, at any time, to revoke this License without cause upon giving of not less than sixty (60) days' notice in writing to the said Licensee, and at the expiration of the time limited by said notice or upon the express revocation of this License for any of the causes enumerated herein, the Licensee shall promptly and in the manner directed by the Public Services Director, through the City Manager, remove the Facility and each and every part thereof hereby authorized, from the licensed premises and leave said premises in the same condition in which it was before the installation of the Facility.
 - C. If the Facility, or any portion thereof, is not removed within sixty (60) days of the receipt of the notice, or such additional time as may be granted in writing by the Licensor, then the Facility, or any part thereof, shall be considered to be abandoned and shall become the property of the Licensor. Upon the refusal or failure of Licensee to remove the Facility, when directed, the Licensor may remove the Facility, and each and every part thereof, and restore the premises to the same condition as before the granting of this License, and the Licensee hereby agrees to pay the Licensor the cost of said removal of the Facility or any part thereof.
7. Assignment. In the event the Facility is conveyed to another party, this License may also be assigned to said party, and upon said assignment said party shall become entitled to all of the rights and privileges granted and shall assume all of the obligations and duties herein provided.
8. Reservations. This License is granted to Licensee subject to all existing easements, rights-of-way, covenants, restrictions and reservations.
9. NO WARRANTY. **LICENSOR DOES NOT WARRANT OR REPRESENT THAT THE PREMISES ARE SAFE, HEALTHFUL, OR SUITABLE FOR THE**

PURPOSES FOR WHICH THEY ARE PERMITTED TO BE USED UNDER THE TERMS OF THIS LICENSE, AND LICENSEE ACCEPTS THE LICENSED PREMISES “AS IS”.

10. Governmental Claims Act. The Licensor does not waive any right or rights it may have pursuant to the Wyoming Governmental Claims Act, Wyoming State Statutes Sections 1-39-101, *et seq.* The licensor specifically reserves the right to assert any and all immunities, rights and defenses it may have pursuant to the Wyoming Governmental Claims Act.
11. Entire Agreement. This License contains the entire agreement between the parties hereto, the terms hereof may not be modified in any respect whatsoever unless in writing by both parties under the signature of the duly authorized representative of Licensor.
12. No Partnership, Joint Venture or Third Party Beneficiaries. Nothing herein contained shall constitute a partnership between or joint venture by the Parties hereto or constitute any Party the agent of the others. No Party shall hold itself out contrary to the terms of this Section and no Party shall become liable by any representation, act or omission of the other contrary to the provisions hereof. This License is not for the benefit of any third Party and shall not be deemed to give any right or remedy to any such party whether referred to herein or not.
13. Changes. No modifications to this License may be made unless they are made in writing, signed by both parties, and approved by the City.
14. Waiver. No failure by the City to insist upon the strict performance of any terms or conditions of the License, or to exercise any right or remedy available on a breach thereof, and no acceptance of full or partial fee payments during the continuance of any such breach shall constitute a waiver of any such breach or of any term or condition of this License. No term or condition of this License required to be performed by the Licensee, and no breach thereof, shall be waived, altered, or modified, except by a written instrument executed by all appropriate parties. No waiver of any breach shall affect or alter any term or condition of this License, and such term or condition shall continue in full force and effect with respect to any other then existing or subsequent breach thereof.
15. Reimbursement of Default, Removal and Eviction Action Expenses. Licensee agrees to pay and indemnify the City against all legal costs and charges, and attorney’s fees, in obtaining possession of the licensed premises after a default of the Licensee, or after the Licensee’s default in surrendering possession of the licensed premises, or for the City enforcing any covenant of the License herein contained.
16. Compliance with Laws. Licensee shall comply with all federal, state or local laws and regulations, including all environmental laws. Licensee shall obtain all required permits, permission, licenses, etc. prior to performing any work on any additional work on City property, easements or rights-of-way.

17. Recording. This License shall be recorded in the Natrona County Clerk's office, and the Licensee shall, at Licensor's option, either pre-pay or reimburse the City of Casper for the cost therefor.
18. Notices. Until a different address is provided in a notice to the other party, all notices, demands or requests made by either party to the other which are required or permitted by the provisions of this License shall be in writing and shall be deemed sufficiently given if: (a) delivered by hand (against a signed receipt); (b) mailed by United States certified or registered mail, return receipt requested, postage prepaid); or (c) sent by nationally recognized commercial overnight delivery service at the following addresses:

Licensor
Attn: Aaron Sopko
General Manager
290 N. Brooks Street
PO Box 7039
Sheridan, Wyoming 82801

City of Casper
Attn: Public Services Director
200 North David
Casper, WY 82601
with a copy to City Attorney Office

Notwithstanding anything contained in this License to the contrary, any notice required to be given by Licensor or Licensee hereunder shall be deemed to be effective as of the date such notice is received or refused as reflected on said notice.

19. Severability. If any term of this License is found to be void or invalid, such finding shall not affect the remaining terms of this License, which shall continue in full force and effect. The parties agree that if any provisions are deemed not enforceable, they shall be deemed modified to the extent necessary to make them enforceable. Any questions of particular interpretation shall not be interpreted against the draftsman, but rather in accordance with the fair meaning thereof.
20. License in City Rights-of-Way. The parties agree that this License covers facilities located in City rights-of-way. Facilities in City rights-of-way will be addressed in a forthcoming franchise agreement between the parties. This License for facilities in City rights-of-way is given as an accommodation to allow the Licensee to install fiber optic services to offices for Casper College, and before a franchise agreement can be completed. This License as it applies to the facilities located in City rights-of-way will terminate automatically, and those facilities will then be subject to the terms and conditions of the franchise ordinance when it takes effect, or will terminate on December 31, 2021, whichever occurs first. If a franchise is not in place by December 31, 2021, the facilities shall be removed unless the parties mutually agree to a time extension.

IN WITNESS WHEREOF, the CITY OF CASPER, WYOMING, has caused this License to be executed on the _____ day of _____, 2020.

APPROVED AS TO FORM:
(ACT – Fiber Optic)

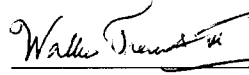

ATTEST:

CITY OF CASPER, WYOMING
A Municipal Corporation

Fleur D. Tremel
City Clerk

Steven K. Freel
Mayor

THE UNDERSIGNED, the Licensee mentioned in the foregoing License, hereby accepts the same subject to the terms and conditions contained therein.

WITNESS:





Aaron Sopko, General Manager
ACT

ACKNOWLEDGMENT

STATE OF WYOMING)
) ss.
COUNTY OF NATRONA)

This instrument was acknowledged before me on the _____ day of _____, 2020, by Steven K. Freel, as the Mayor of the City of Casper, Wyoming.

Notary Public

My commission expires: _____

STATE OF *Wyoming*)
) ss.
COUNTY OF *Sheridan*)

This instrument was acknowledged before me on the 18th day of June, 2020, by Aaron Sapko.

Cheryl Jackson
Notary Public

My commission expires: 6-7-2021

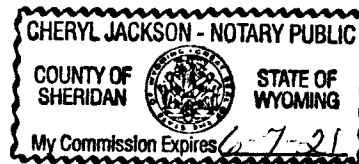

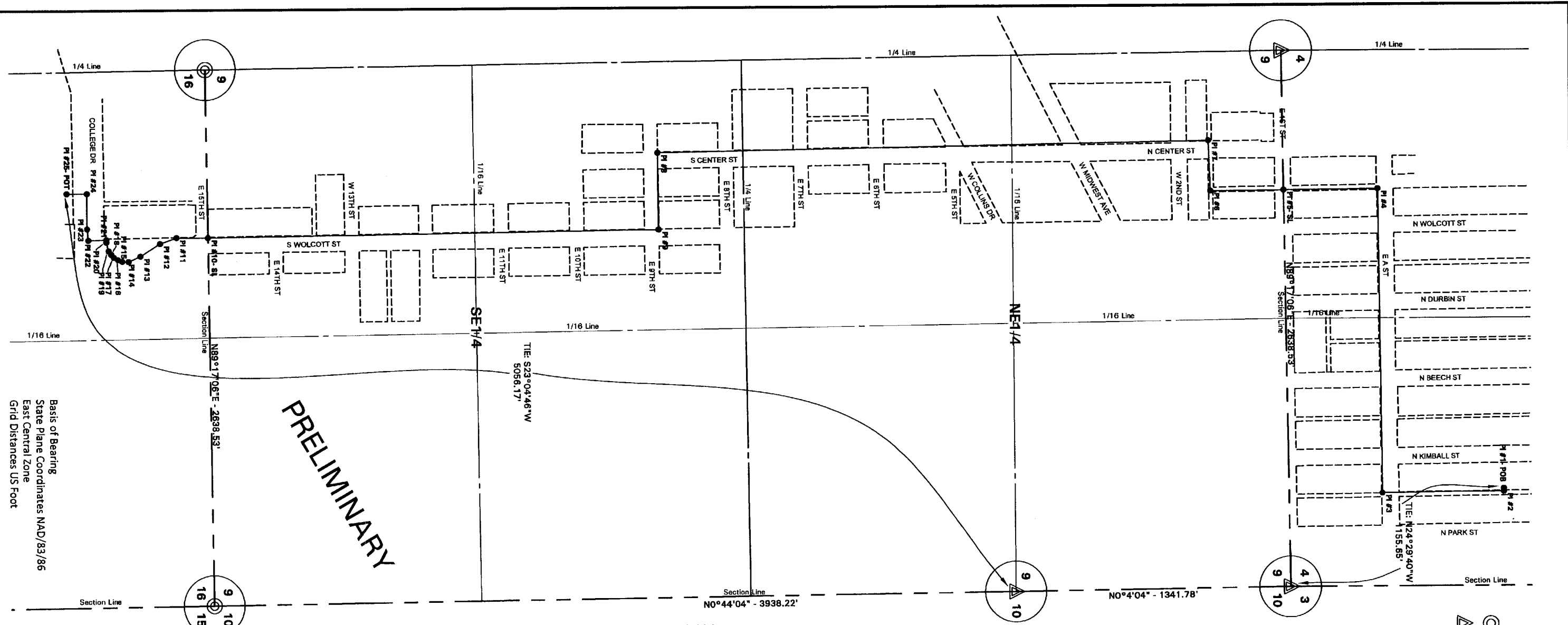

EXHIBIT "A"
Casper Preliminary ACT Fiber Optic
 S1/2SE1/4 OF SEC. 4, T-33-N, R-79-W, E1/2 SEC 9 T-33-N, R-79-W,
 N1/2NE1/4 OF SEC. 16, T-33-N, R-79-W
 6th Principal Meridian, Wyoming
 Casper, Natrona County Wyoming

A tract of land located in the South Half of the Southeast Quarter of Section 4, East Half of Section 9, and the North Half of the Northeast Quarter Section 16, Township 33 North, Range 79 West of the 6th Principal Meridian, Casper Natrona County, State of Wyoming, being more particularly described as a strip of land five (5) feet in width, two and one-half (2.5) feet on each side of the following described centerline:

COMMENCING at the southeast corner of said Southeast Quarter of Section 4, As shown on Natrona County Instrument # 682443, thence N24°29'40"W a distance of 1155.65 feet to the POINT OF BEGINNING; thence N88°49'21"E a distance of 14.01 feet; thence S00°33'51"E a distance of 596.81 feet; thence S89°21'00"W a distance of 1497.57 feet; thence S00°28'36"E a distance of 462.55 feet to the south line of said Section 4; thence S00°24'41"E a distance of 355.46 feet; thence S87°59'09"W a distance of 247.50 feet; thence S00°59'52"E a distance of 2698.05 feet; thence N89°26'18"E a distance of 377.76 feet; thence S00°45'30"E a distance of 2219.90 feet to the south line of said Section 9; thence S00°20'08"W a distance of 155.10 feet; thence S19°20'43"E a distance of 86.80 feet; thence S32°12'38"E a distance of 114.03 feet; thence S24°43'31"E a distance of 63.39 feet; thence S02°09'13"W a distance of 30.68 feet; thence S21°27'09"W a distance of 23.33 feet; thence S27°12'44"W a distance of 22.72 feet; thence S48°13'06"W a distance of 20.40 feet; thence S54°13'53"W a distance of 21.83 feet; thence S76°05'31"W a distance of 44.38 feet; thence N89°47'15"W a distance of 11.86 feet; thence S01°25'43"E a distance of 87.28 feet; thence S84°26'31"W a distance of 56.03 feet; thence S89°53'28"W a distance of 174.55 feet; thence S00°12'36"W a distance of 97.37 feet to the POINT OF TERMINUS; said point lies S23°04'46"W a distance of 5056.17 feet from the east corner of the Northeast Quarter of said Section 9.

Said tract contains 9479.36 feet or 574.51 rods. (1.09 acres).
 Basis of bearing N89°17'06"E is the south line of the Southeast Quarter of Section 4, T33N, R79W.



PI #	STATIONING	DIRECTION	DISTANCE
1-POB	0+00.00	N88°49'21"E	14.01'
2	0+14.01	S00°33'51"E	596.81'
3	6+10.82	S89°21'00"W	1497.57'
4	21+08.39	S00°28'36"E	462.55'
5-SL	25+70.94	S00°24'41"E	355.46'
6	29+26.40	S87°59'09"W	247.50'
7	31+73.90	S00°59'52"E	2698.05'
8	58+71.95	N89°26'18"E	377.76'
9	62+49.71	S00°45'30"E	2219.90'
10-SL	84+69.61	S00°20'08"W	155.10'
11	86+24.71	S19°20'43"E	86.80'
12	87+11.51	S32°12'38"E	114.03'
13	88+26.54	S24°43'31"E	63.39'
14	88+88.93	S27°12'44"W	22.72'
15	89+19.61	S48°13'06"W	20.40'
16	89+42.94	S54°13'53"W	21.83'
17	89+65.66	S76°05'31"W	44.38'
18	89+86.06	N89°47'15"W	11.86'
19	90+07.89	S01°25'43"E	87.28'
20	90+52.27	S84°26'31"W	56.03'
21	90+64.13	S89°53'28"W	174.55'
22	91+51.41	S00°12'36"W	97.37'
23	92+07.44	S00°12'36"W	97.37'
24	93+81.99	S00°12'36"W	97.37'
25-POB	94+79.36		

Casper ACT Fiber Optic

S1/2SE1/4 of Sec. 4, E1/2 Sec. 9,
 N1/2NE1/4 of Sec. 16
 T-33-N., R-79-W., 6th P.M.,
 Natrona County, Wyoming

Scale: 1" = 500'

KLJ

DATE: 6/4/2020

RESOLUTION NO. 20-142

A RESOLUTION AUTHORIZING A LICENSE AGREEMENT WITH ADVANCED COMMUNICATIONS TECHNOLOGY, INC. (ACT), TO INSTALL BURIED FIBER OPTIC CABLE INFRASTRUCTURE WITHIN CITY RIGHT-OF-WAY PROPERTY.

WHEREAS, ACT has requested permission from the City to use City right-of-way for constructing, altering, operating, maintaining, inspecting, repairing, replacing and removing underground fiber optic cable infrastructure from East "C" Street and Kimball Street to the Casper College campus; and,

WHEREAS, the City of Casper has determined that the use of said City right-of-way will not unreasonably interfere with the use thereof by the City or the general public.

NOW, THEREFORE, BE IT RESOLVED BY THE GOVERNING BODY OF THE CITY OF CASPER, WYOMING: That the Mayor is hereby authorized and directed to execute, and the City Clerk to attest, a License Agreement with ACT for the purpose of using certain City right-of-way for constructing, altering, operating, maintaining, inspecting, repairing, replacing and removing underground fiber optic cable infrastructure, more particularly described in said license agreement, and specifically subject to the conditions set forth therein.

PASSED, APPROVED, AND ADOPTED this ____ day of _____, 2020.

APPROVED AS TO FORM:

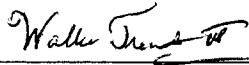

ATTEST:

CITY OF CASPER, WYOMING
A Municipal Corporation

Fleur Tremel
City Clerk

Steven K. Freel
Mayor

June 23, 2020

MEMO TO: J. Carter Napier, City Manager 

FROM: Andrew Beamer, P.E., Public Services Director 
Tim Cortez, Parks & Recreation Director
Alex Sveda, P.E., Associate Engineer

SUBJECT: Authorizing Change Order No. 8 with Haass Construction Company, Inc., in the Amount of \$12,819.50 and a Time Extension of 21 Days, for the Casper Ice Arena Ice Chiller System Replacement, Project No. 15-58.

Meeting Type & Date

Regular Council Meeting
July 7, 2020

Action type

Resolution

Recommendation

That the City Manager authorize Change Order No. 8 (CO8) with Haass Construction Co., Inc. (Haass), in the Amount of \$35,375.00 and a time extension of 21 days, for the Casper Ice Arena Ice Chiller System Replacement, Project No. 15-58.

Summary

Haass is under contract with the City of Casper for the Casper Ice Arena Ice Chiller System Replacement, Project No. 15-58. The work of this project includes relocation, refurbishment and reuse of the existing, indirect ammonia ice chilling equipment at the Casper Events Center (CEC) to replace the existing R22 system at the Ice Arena, including a new building required to house the reused ice chilling equipment at the Ice Arena. The reused equipment is expected to be capable of serving a future, second sheet of ice and will be stubbed out to facilitate future expansion.

CO8 consists of the labor and materials required to remove and replace the existing 18-inches of subgrade soils in the Ice Arena. On June 8, the existing subgrade soils were tested and failed to meet the proper compaction to structurally support the new concrete floor and subfloor chilling system. This issue was not anticipated during the design process because the geotechnical report and records did not show unsuitable soils at this location.

The amount for CO8 is \$35,375.00. This includes removal of the existing soils and replacement with structural geofabric and suitable soil materials. A time extension of three weeks or 21 calendar days has been requested to completed the additional work of CO8.

The project was designed by B32 Engineers (B32), and they are currently under contract for design and construction administration services for the work. B32 and City of Casper Staff recommend the approval of CO8 with Haass in the amount of \$35,375 and a time extension of 21 days.

With CO8, construction of the improvements is to be substantially complete by November 6, 2020.

Financial Considerations

Project funding is from the Perpetual Care fund, One Percent #16 funds for City of Casper Buildings and the FY16 CIA Ice Making System Replacement 1%#15 fund.

CO8 will come from contingency funds set for the project. With CO8, the remaining contingency balance will be \$11,687.15.

Oversight/Project Responsibility

Alex Sveda, P.E., Associate Engineer, Public Services Department.

Attachments

Resolution

CO8

B32 Recommendation

CITY OF CASPER

CHANGE ORDER

NO. Eight (8)

PROJECT: Casper Ice Arena Ice Chiller System Replacement, Project No. 15-58

DATE OF ISSUANCE: February 28, 2020

OWNER: City of Casper, Wyoming CONTRACTOR: Haass Construction Company, Inc.

ARCHITECT/ENGINEER: B32 Engineering Group, Inc.

You are directed to make the following changes in the Contract Documents:

Description: Replacement of existing unsuitable soils beneath the ice rink floor as detailed in attached B32 Proposal Request No. 10

Attachments: -Haass CPR #010
-B32 PR No.10

CHANGE IN CONTRACT PRICE	CHANGE IN CONTRACT TIME
Original Contract Price: \$ <u>2,452,500.00</u>	Original Contract Time: (days or date) Substantial completion: <u>October 16, 2020</u> ; Final completion: <u>October 23, 2020</u>
Previous Change Orders No. <u>1</u> to <u>7</u> : \$ <u>62,421.95</u>	Net change from previous Change Orders (days): <u>--0--</u>
Contract Price prior to this Change Order: \$ <u>2,527,741.45</u>	Contract Time prior to this Change Order: Substantial completion: <u>October 16, 2020</u> ; Final completion: <u>October 23, 2020</u>
Net Increase/ Decrease change of this Change Order: \$ <u>35,375.00</u>	Net Increase/ Decrease of this Change Order: (days) <u>-- 21 --</u>
Contract Price with all approved Change Orders: \$ <u>2,563,116.45</u>	Contract Time with all approved Change Orders: Substantial completion: <u>November 6, 2020</u> ; Final completion: <u>November 13, 2020</u>

ACCEPTED:

RECOMMENDED:

APPROVED:

BY: John Haass
Contractor

BY: Debra A. Wolf
Architect/Engineer

BY: _____
Owner



June 23, 2020

Alex Sveda, PE
Associate Engineer
City of Casper
200 N. David St.
Casper, WY 82601

Via email: asveda@casperwy.gov

Re: Casper Ice Arena Ice Chiller System Replacement
B32 File No. 900-15-243 / City of Casper File No. 15-58
Change Order No. 8

Dear Alex:

Enclosed is Change Order No. 8 for the above referenced project. This Change Order is to replace existing unsuitable soils beneath the ice rink floor. It is also a request to extend the Substantial Completion Date by 3 weeks due to this additional work.

The pricing appears to be fair and the contractor has provided back cost information. We recommend the City accept this change order. Please have the first page of the change order signed and emailed back to me and I will distribute to the Contractor.

If you have any questions regarding this documentation or the project in general, please feel free to call us anytime. Our office number is 651.256.3090.

Sincerely,

A handwritten signature in black ink that reads "Scott A. Ward".

Scott Ward, PE
President and Project Manager

Enclosures



Change Proposal Request (CPR)

Project Information	
Project #	2004
Title	Casper Ice Arena
Address	1801 E. 4th Street
City, State, Zip	Casper, WY 82601
Country	

Change Proposal Request	
Contract #	2004 Ice Arena
CPR #	010
Issue Date	16-Jun-2020
Subject	PR 10 - Fabric and Subgrade Improvements

Prime Contract Company	
Contact	Adam Haass ADMIN
Company	Haass Construction
Address	1302 E. C St.
City, State, Zip	Casper, WY 82601
Country	United States
Phone	(307) 265-9064
Fax	(307) 266-4301

Owner	
Contact	
Company	City of Casper WY
Address	
City, State, Zip	
Country	
Phone	
Fax	

Description of the proposed change:

Net Amount of this Proposed Change:

\$35,375.00

The Contract time due to this Change Proposal Request is to be determined at a later date.

This document, when fully executed as accepted, shall constitute authorization to proceed with the work described herein.

Submitted By _____
 Haass Construction
 Company

Response: Accept Do Not Accept

 City of Casper WY
 Company

By _____ Date _____

By _____ Date _____



Change Proposal Request (CPR)

Proposed Items

Item #	Item Description	Quantity	Unit	Unit Price	Subtotal
1	Supply and Install fabric	1	LS	18,175.00	18,175.00
2	Supply of 3/4" minus material	1	LS	17,200.00	17,200.00

Subtotal = \$35,375.00

Tax = \$0.00

Total = \$35,375.00

Proposal Request

No. 10

Date of Issuance: June 10, 2020 Rev I. Jun 11

Project: Casper Ice Arena Ice Chiller Replacement	Owner: City of Casper, Wyoming	Owner's Contract No.: 15-58
Contract: Ice Chiller Replacement		Date of Contract: February 14, 2020
Contractor: Haass Construction Company, Inc.		Engineer's Project No.: 900.15.243

This document has important legal consequences; Consultation with an Attorney is encouraged, with respect to its completion or modification.

Please submit an itemized proposal for changes in the Contract Sum and Contract Time for proposed modifications to the Contract Documents described herein. Submit a proposal within 5 calendar days or notify the Engineer in writing of the date on which you anticipate submitting your proposal.

THIS IS NOT A CHANGE ORDER, A CONSTRUCTION CHANGE DIRECTIVE OR A DIRECTION TO PROCEED WITH THE WORK DESCRIBED IN THE PROPOSED MODIFICATIONS. Contractor shall provide a proposal, broken down into units of labor, units of materials, overhead and profit, to accomplish the revision work described below.

Reference:	131813 – Ice Rink Floor Systems (Specification Section(s))	R100, R101, R500, R501 (Drawing(s) / Detail(s))
-------------------	---	--

Description:

The existing rink floor subgrade has been excavated to minus 18" below FF/final ice rink floor elevation per Hass Construction. The existing material in place includes 6" of existing soil (sandy loam), geofabric (at minus 24") and reportedly some type of washed rock or aggregate material beneath the existing fabric. The subgrade was test rolled yesterday by AET and failed. The material pumped up, ~~see AET's follow up email~~. No density or moisture testing was performed on this material.

Provide the following subgrade improvements as recommended by AET. Remove and dispose of the existing subgrade material that has already been removed from the arena. Remove and dispose of 6" of remaining existing material over the existing fabric. Provide a new geogrid material (Marifi RS580i or approved equal) on top of the existing fabric. Provide 9" of ¾" minus aggregate base material on top of geogrid. Provide 7" of clean washed sand (combination of the existing salvaged rink floor sand and new clean washed sand) for the subflooring heating layer over the aggregate base material. Change the subflooring piping invert elevation from minus 14" to minus 13" below FF/final ice rink floor elevation. This means the subflooring heating pipes should be bedded on top of approximately 2" of clean washed sand. Do not bed pipe on aggregate base material or any rocky material. See additional requirements in attached email by AET.

Just a reminder to provide survey of subgrade material as specified in Section 131817.3.02.D.1, prior to installing subfloor heating pipes. Notify AET for compaction tests as subgrade is backfilled.

Credits:

Drawing Sheet R501 requires removing, reinstalling and recompacting subgrade soils 36" below the ice rink floor. Since the existing fabric is between minus 24" and 30", provide credit for not moving 6" to 12" of existing soil.

Adam@haassconstruction.com

From: Deadgrizz <deadgrizz@aol.com>
Sent: Tuesday, June 16, 2020 5:33 AM
To: Adam@haassconstruction.com
Subject: RE: FW: CIA PR 10 Fabric and subgrade improvements

Adam,

Supply of fabric and placement is \$18,175.00. Supply of 3/4" minus material is \$17,200.00
Pete Peterson
Recycled Materials

On Thursday, June 11, 2020 Adam <Adam@haassconstruction.com> wrote:

PR 10 revised

From: Scott Ward <scott.ward@b32eng.com>
Sent: Thursday, June 11, 2020 3:08 PM
To: Adam@haassconstruction.com
Cc: 'Alex Sveda' <asveda@casperwy.gov>
Subject: RE: CIA PR 10 Fabric and subgrade improvements

Adam,

See revised PR10 with AET comments attached.

Scott

Scott A. Ward, P.E.

President

B32 Engineering Group, Inc.

D. 715.245.8839 O. 651.256.3090 ext.102 C. 651.492.1376

www.b32eng.com

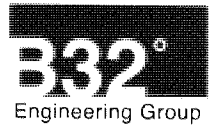

Attachments:

None

Signature: Scott A. Ward, P.E.

Date: 6.10.20

Copies to:

OWNER:	Alex Sveda
ENGINEER:	Scott Ward
CONTRACTOR:	Adam Haass

Scott Ward

From: Jung, Jared <jjung@amengtest.com>
Sent: Thursday, June 11, 2020 2:23 PM
To: Scott Ward
Cc: Jensen, Stephen
Subject: RE: Casper Ice Arena - Recommendation for subgrade correction

Hi Scott –

Per our discussion the contractor shall remove the existing grade down to at or near the old fabric layer. The contractor shall limit construction traffic as much as possible. A geotextile consisting of Marifi RS580i or approved equivalent shall be placed on the exposed subgrade. A WYDOT grading “W” shall be placed on the top of the geotextile (approximately 9”). Contractor shall push out material on top of the geotextile to minimize traffic on the geotextile until at least 6 inches of base course is applied. Compaction testing shall be performed at the top of the base course layer to achieve a minimum of 95% ASTM D698 to -4 to plus 2% of optimum moisture content.

Let me know if you need anything else.

Jared

Jared J. Jung, PE*

Casper Manager

jjung@amengtest.com

D: 307.266.2931 | C: 307.259.4302



American Engineering Testing, Inc.

605 North Warehouse Road

Casper, WY 82601

*ND, WY

www.amengtest.com

Please read our email disclaimer at this [link](#) on our website.

From: Scott Ward <scott.ward@b32eng.com>
Sent: Thursday, June 11, 2020 1:14 PM
To: Jung, Jared <jjung@amengtest.com>
Subject: Casper Ice Arena - Recommendation for subgrade correction

[Warning - External Source] Please be careful about responding to or opening any attachments or links in this message, as it c

Jared,

Just a reminder to send me an email with your observation of the test roll failure and subgrade correction recommendation as discussed. Attached is the proposal request I wrote based on our discussion. Please review and make sure I stated your recommendation accurately. Please send recommendation asap. Contractor is waiting for it to move forward.

Thanks,

Scott

Scott A. Ward, P.E.

(Licensed: AK, AZ, CO, CT, FL, IA, IL, MA, MD, ME, MI, MN, MO, NC, ND, NE, NH, NJ, NM, NY, OH, PA, SD, TN, TX, VT, WI, WV, WY)
President



2211 O'Neil Road, Hudson, Wisconsin 54016
D. 715.245.8839 O. 651.256.3090 ext.102 C. 651.492.1376
www.b32eng.com

RESOLUTION NO. 20-143

A RESOLUTION AUTHORIZING CHANGE ORDER NO. 8 TO THE AGREEMENT WITH HAASS CONSTRUCTION CO., INC., FOR CASPER ICE ARENA ICE CHILLER SYSTEM REPLACEMENT, PROJECT NO. 15-58.

WHEREAS, Haass Construction Co., Inc. is currently under contract with the City of Casper for the Casper Ice Arena Ice Chiller System Replacement, Project No. 15-58; and,

WHEREAS, the City of Casper desires to replace unsuitable structural soils at the Casper Ice Arena in the amount of Thirty-Five Thousand Three Hundred Seventy-Five and 00/100 Dollars (\$35,375.00) and grant a time extension of twenty-one (21) days; and,

WHEREAS, Haass Construction Co., Inc., is able and willing to provide those services specified as Change Order No. 8 to the Casper Ice Arena Ice Chiller System Replacement, Project No. 15-58.

NOW, THEREFORE, BE IT RESOLVED BY THE GOVERNING BODY OF THE CITY OF CASPER, WYOMING: That the Mayor is hereby authorized and directed to execute Change Order No. 8 to the agreement between the City of Casper and Haass Construction Co., Inc. for performing additional work related to Casper Ice Arena Ice Chiller System Replacement, Project No. 15-58, for a price increase in the amount of Thirty-Five Thousand Three Hundred Seventy-Five and 00/100 Dollars (\$35,375.00) and a time extension of twenty-one (21) days.

BE IT FURTHER RESOLVED: That the City Manager is hereby authorized to make verified partial payments throughout the project, retaining those amounts prescribed by the agreement, for a total revised contract amount of Two Million Five Hundred Sixty-Three Thousand One Hundred Sixteen and 45/100 Dollars (\$2,563,116.45).

PASSED, APPROVED, AND ADOPTED this ____ day of _____, 2020.

APPROVED AS TO FORM:
(Casper Ice Arena Ice Chiller System Replacement, Project No. 15-58)



ATTEST:

CITY OF CASPER, WYOMING
A Municipal Corporation

Fleur Tremel
City Clerk

Steven K. Freel
Mayor

June 24, 2020

MEMO TO: J. Carter Napier, City Manager 

FROM: Andrew Beamer, P.E., Public Services Director 
Ethan Yonker, P.E., Associate Engineer

SUBJECT: Accepting a Right-of-Way Easement from the Board of Natrona County Commissioners, as part of the Midwest Avenue Reconstruction from Elm Street to Walnut Street, Project No. 18-066.

Meeting Type & Date

Regular Council Meeting
July 7, 2020

Action Type

Resolution

Recommendation

That Council, by resolution, accept a 60 square foot right-of-way easement from the Board of Natrona County Commissioners, as part of the Midwest Avenue Reconstruction from Elm Street to Walnut Street, Project No. 18-066.

Summary

The Midwest Avenue Reconstruction from Elm Street to Walnut Street has been awarded to a contractor. During design, it was found that an easement from Natrona County would be required at the intersection of Midwest Avenue and the alley between Spruce and Oak Streets to allow for lane widths, turning radii, and on street parking to remain uniform throughout the project.

The easement and legal descriptions have been prepared by WWC Engineering and have been approved by the Board of Natrona County Commissioners.

Financial Considerations

There are no financial considerations for this easement.

Oversight/Project Responsibility

WWC Engineering
Ethan Yonker, P.E., Associate Engineer, Public Services Department

Attachments

Resolution
Easement

RIGHT-OF-WAY EASEMENT

KNOW ALL PERSONS BY THESE PRESENTS:

That for and in consideration of the sum of Ten (\$10.00) Dollars and other good and valuable consideration, the receipt and sufficiency of which are hereby acknowledged and confessed, the parties agree as follows:

1. Board of County Commissioners of Natrona County, Wyoming, whose address is 200 North Center Street, Casper, Wyoming 82601 (herein referred to as "Grantor"), HEREBY GRANTS to the City of Casper, Wyoming, a Municipal Corporation, whose principal offices are located at 200 North David Street, Casper, Wyoming, 82601 (herein referred to as "Grantee"), a perpetual easement for the construction, maintenance, repair, replacement, and removal of undergrounds utilities, roadways, sidewalks, curbs & gutters, lighting, and street furniture, (hereinafter referred to as the "Facilities") over, across and under the real property located within the County of Natrona, Wyoming and legally described and depicted on EXHIBIT "A", attached hereto and hereinafter referred to as the Easement Property. Grantor also grants the right of access on and along the Easement Property for any and all purposes necessary for laying out, constructing, inspecting, maintaining, and replacing the Facilities located on the Easement Property.

2. The Parties do not waive any right or rights they may have pursuant to the Wyoming Governmental Claims Act, Wyoming Statutes Section 1-39-101 et seq., and hereby specifically reserves the right to assert any and all rights, immunities, and defenses they may have pursuant to the Wyoming Governmental Claims Act.

3. This Instrument, and any subsequent amendments, shall be recorded in the real property records of the Clerk and Recorder of Natrona County, Wyoming.

4. All provisions of this Instrument, including the benefits and burdens, are appurtenant to and run with the real property and are binding upon and inure to the benefit of the successors and assigns of the parties hereto.

Dated this 16th day of June, 2020.

APPROVED AS TO FORM:

Walter Trout

GRANTOR:
By: [Signature]
Board of County Commissioners
Robert L. Hendry

CITY OF CASPER:
By: Steven K. Freel
Mayor

Attest:
By: Fleur Tremel
City Clerk

STATE OF WYOMING)
)ss.
COUNTY OF NATRONA)

This instrument was acknowledged before me on this _____ day of _____, 2019, by Steven K. Freel as Mayor of the City of Casper.

(Seal, if any) _____
(Signature of notarial officer)

[My Commission Expires: _____]

STATE OF WYOMING)
)ss.
COUNTY OF NATRONA)

This instrument was acknowledged before me on this 16th day of June, 2019, by Robert L. Hendry, Chairman of the Board of County Commissioners.

(Seal, if any) [Signature]
(Signature of notarial officer)

[My Commission Expires: 11/14/2021]

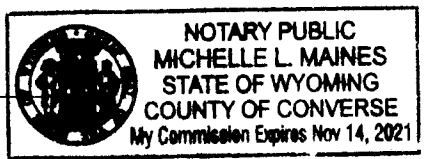

APPROVED AS TO FORM
NATRONA COUNTY ATTORNEY

BY: [Signature]
DATE: 6-16-2020

EXHIBIT A

LEGAL DESCRIPTION:

A parcel of land being a portion of Lot 10, Block 21, City of Casper, Wyoming as recorded in Book 1, Page 404 and a portion of the parcel described in Instrument #637530, as recorded in the Office of County Clerk of Natrona County, and also being a portion of the NE1/4NW1/4 of Section 9, Township 33 North, Range 79 West of the Sixth Principal Meridian, Natrona County, Wyoming, said Parcel being more particularly described by metes and bounds as follows;

Beginning at the southwest corner of said Lot 10, thence along the east line of the alley, N 00° 39' 20" W, 3.50 feet ; thence N 68° 18' 41" E, 36.96 feet, more or less, to a point on the southerly boundary of said Lot 10 and a point in the northwest line of Midwest Avenue, also being the southeasterly corner of parcel as described in Instrument #637530; thence along southerly boundary of said Lot 10 and along the north line of Midwest Avenue, S 63° 25' 53" W, 38.36 feet to the Point of Beginning and containing 60 square feet, more or less.

LEGEND:

- L/L —— LOT LINE
- P/L —— PROPERTY LINE
- PROPOSED EASEMENT LINE
- - - - - ROW LINE

NOTES

1. DISTANCES: U.S. SURVEY FEET
2. BASIS OF BEARING: NAD83(86) WYOMING STATE PLANE COORDINATE SYSTEM, EAST CENTRAL ZONE

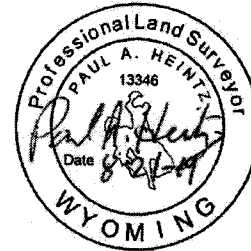

CERTIFICATE OF SURVEYOR

THIS IS TO CERTIFY THAT THE ABOVE PLAT WAS PREPARED FROM FIELD NOTES OF ACTUAL SURVEYS MADE BY ME OR UNDER MY SUPERVISION AND THAT THE SAME ARE TRUE AND CORRECT TO THE BEST OF MY KNOWLEDGE AND BELIEF.

SCALE 1" = 30'

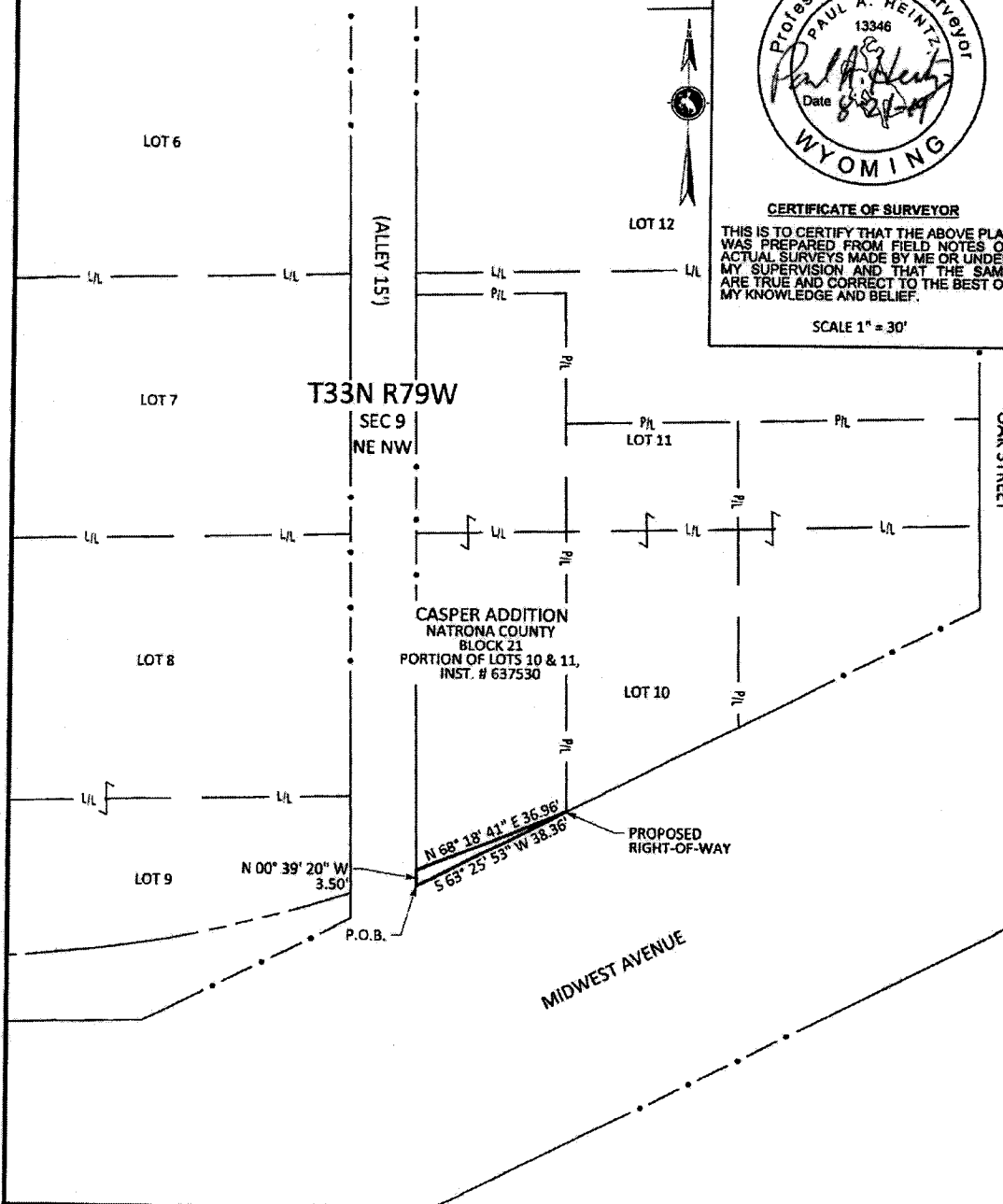

<p>DRAWING SHEET CASMT-3</p>	<p>MIDWEST AVENUE RECONSTRUCTION RIGHT-OF-WAY EASEMENT DETAIL NATRONA COUNTY</p>	<p>ISSUED BY: [] DATE: [] REVISED: [] APPROVED: [] DATE: []</p>	<p>CITY OF CASPER</p>	<p>WWC ENGINEERING</p>	<p>COPYRIGHT 2015</p>
------------------------------	---	--	-----------------------	------------------------	-----------------------

RESOLUTION NO. 20-144

A RESOLUTION ACCEPTING A RIGHT-OF-WAY EASEMENT FROM THE BOARD OF NATRONA COUNTY COMMISSIONERS FOR THE MIDWEST AVENUE RECONSTRUCTION FROM ELM STREET TO WALNUT STREET PROJECT.

WHEREAS, the City of Casper is reconstructing the portion of Midwest Avenue from Elm Street to Walnut Street; and,

WHEREAS, approval of a Right-of-Way Easement with the Board of Natrona County Commissioners will allow for proper turning radii and on street parking at the intersection of Midwest Avenue and the alley between Spruce Street and Oak Street; and,

WHEREAS, the easement with the Board of Natrona County Commissioners does not require compensation.

NOW, THEREFORE, BE IT RESOLVED BY THE GOVERNING BODY OF THE CITY OF CASPER, WYOMING: That the Mayor is hereby authorized and directed to execute, and the City Clerk to attest, a Right-of-Way Easement with Board of Natrona County Commissioners for the Midwest Avenue Reconstruction from Elm Street to Walnut Street Project, and specifically subject to the conditions set forth therein.

PASSED, APPROVED, AND ADOPTED this ____ day of _____, 2020.

APPROVED AS TO FORM:

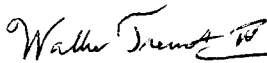

ATTEST:

CITY OF CASPER, WYOMING
A Municipal Corporation

Fleur Tremel
City Clerk

Steven K. Freel
Mayor

June 24, 2020

MEMO TO: J. Carter Napier, City Manager *JCN*

FROM: Andrew Beamer, P.E., Public Services Director *AB*
Terry Cottenoir, Engineering Technician

SUBJECT: Authorizing Submission of an Application for a Fiscal Year 2021 Transportation Alternatives Program Funding from the Wyoming Department of Transportation in the Amount of \$500,000.00, for the Paradise Valley to Robertson Road Bridge.

Meeting Type & Date

Regular Council Meeting
July 7, 2020

Action type

Resolution

Recommendation

That Council, by resolution, authorize the submission of an Application for a Fiscal Year 2021 (FY21) Transportation Alternatives Program (TAP) Funding from the Wyoming Department of Transportation (WYDOT), in the amount of \$500,000.00, to fund the construction of the Paradise Valley to Robertson Road Bridge.

Summary

The City of Casper has contracted HDR Engineering, Inc. (HDR), to design a multi-phase Paradise Valley to Robertson Road Trail Project. As a part of this project, the City of Casper the Platte River Trails Trust (PRTT) are preparing a WYDOT TAP funding application to construct a pedestrian bridge and pathway connections to the Robertson Road Pathway and the neighborhoods of Paradise Valley. The TAP program is a source of federal funding that provides monies to state and local governments for transportation projects. The program emphasizes projects that support walkability and pedestrian safety. TAP grants require a 20% local match.

The project will include construction of a pedestrian bridge that connects Paradise Valley to Robertson Road. Additionally, new ten foot (10') wide concrete pathways will be constructed to connect the pedestrian bridge to the Robertson Road Pathway to the west and Indian Paintbrush to the east. The project will provide a safe route for non-drivers to access the neighborhoods and schools along Robertson Road in west Casper from the Platte River Trail.

HDR has developed a cost estimate in the amount of \$1,250,000.00. If TAP funding is awarded in the amount of \$500,000, the City and PRTT will be required to supply \$125,000.00 in matching funds, as well as the additional \$625,000.00 to cover the remaining costs of the project.

Financial Considerations

The total budget for the TAP funding portion of this project is \$625,000.00. \$500,000.00 is expected to come from the TAP funding. The City will be supplying its match in the amount of \$125,000.00 from the One Cent #14, One Cent #15, and One Cent #16 Optional Sales Tax Funds allocated to the PRTT for FY2021. The PRTT is working towards securing the remaining \$625,000.00 to complete the project. The PRTT has been successful over the past 30 plus years leveraging funds from sources such as the Natrona County Recreation Joint Powers Board and private and public foundations to complete trail infrastructure projects.

Oversight/Project Responsibility

Terry Cottenoir, Engineering Technician, Public Services Department.

Attachments

Resolution

TAP Grant Application

**Transportation Alternatives Program (TAP) Applicant Information****Sponsor:**

Name of Sponsor: City of Casper		
Sponsor Type: Local Government		
Specify Other:		
DUNS: 152720140		
Mailing Address: 200 North David Street		
City: Casper	State: WY	Zip: 82601
Project Name: Paradise Valley to Robertson Road Bridge		

Contact Person: Terry Cottenoir		
Title: Engineering Technician		
Email: tcottenoir@casperwy.gov		Phone: (307) 235-8341
LPA Certified: <input checked="" type="checkbox"/> Yes <input type="checkbox"/> No	LPA Certification Expiration: 12/31/2020	
LPA Certified Individual (if not Contact Person):		

Joint Sponsor:

Joint Sponsor: <input type="checkbox"/> No <input checked="" type="checkbox"/> Yes - Joint Sponsor's Name: Platte River Trails Trust		
Mailing Address:P.O. Box 1228		
City: Casper	State: WY	Zip: 82602

Contact Person: Angela Emery		
Title: Executive Director		
Email: platteriver@wyoming.com		Phone: (307) 258-8833

Funding Request

20% Local Match	80% Federal (TAP Request)	Total Project Cost
\$125,000.00	\$500,000.00	\$625,000.00
Specify source of secured funding:One Cent #16 Sales Tax Allocation to Platte River Trails		

Sponsor Certification Statement

Read and check each statement below certifying:

- The Sponsor is familiar with the Transportation Alternatives Program eligibility criteria;
- The budget accurately reflects cost of proposed project;
- The information provided is true and correct to the best of the Sponsor's knowledge;
- The Sponsor understands this is a reimbursement-based award and if funded, the Sponsor must pay costs and will be reimbursed as invoices are submitted with documentation;
- The Sponsor will be responsible for ensuring future maintenance and ongoing upkeep of the completed project.

Sponsor Signature
 (Authorized Official)
 Steven K. Freel, Mayor - City of Casper

Date



TAP Attachment A: Project Description

City of Casper

Nature of Project:

<input type="checkbox"/> Planning/Design
<input checked="" type="checkbox"/> Construction

Project Type/Planning Document Considerations (Select all that apply):

Non-Motorized Transportation	
<input checked="" type="checkbox"/> ADA Upgrades	<input type="checkbox"/> ADA Transition Plan
<input checked="" type="checkbox"/> Safe Routes for Non-Drivers	<input checked="" type="checkbox"/> Pedestrian and Bicycle Facilities
<input type="checkbox"/> Conversion of Abandoned Railway Corridors to Trails	
Environmental Mitigation	
<input type="checkbox"/> Vegetation Management	<input type="checkbox"/> Storm Water Mitigation <input type="checkbox"/> Wildlife Management
Historic/Scenic Transportation Activities	
<input type="checkbox"/> Scenic Turnouts and Overlooks	
<input type="checkbox"/> Outdoor Advertising Management <input type="checkbox"/> Archeological Activities	
<input type="checkbox"/> Historic Preservation and Rehabilitation of Historic Transportation Facilities	

Project Location:

Describe the location of the project using any mileposts, landmarks, significant intersections, etc. City property at intersection of Indian Paintbrush and Yarrow Street across the North Platte River to City property on Robertson Road near Little Moon Trail Road

Physical Description:

Pathway Type: Multi-Use Pathway	
Surface Type: Concrete	If Other, please specify: Bridge is Composite
Approximate Length: 1400 ft <input type="checkbox"/>	Approximate Width: 10 ft <input type="checkbox"/> N/A
N/A	

Project Timeline:

Completion of PS&E	Completion of Final Engineering/Bid Documents	Bid Advertisement	Begin Construction	Complete Project
8/28/2020	3/1/2021	4/15/2021	10/1/2021	11/30/2021

Project Benefits:

Check the following connections that this project provides (Must be within ½ mile of the start/end of the proposed project):		
<input checked="" type="checkbox"/> Residential to Residential	<input checked="" type="checkbox"/> Residential to Retail/Dining	<input checked="" type="checkbox"/> Residential to Education
<input checked="" type="checkbox"/> Residential to Recreation	<input checked="" type="checkbox"/> Residential to Employment	<input checked="" type="checkbox"/> Employment to Retail/Dining



<input checked="" type="checkbox"/> Employment to Recreation	<input checked="" type="checkbox"/> Employment to Education	<input checked="" type="checkbox"/> Recreation to Retail/Dining
<input type="checkbox"/> N/A		
Does the project provide a new connection?		<input checked="" type="checkbox"/> Yes <input type="checkbox"/> No <input type="checkbox"/> N/A
Does the project fill a sidewalk or pathway gap ("missing link")?		<input checked="" type="checkbox"/> Yes <input type="checkbox"/> No <input type="checkbox"/> N/A
Will the project induce non-motorized trips?		<input checked="" type="checkbox"/> Yes <input type="checkbox"/> No <input type="checkbox"/> N/A
Briefly describe the improvements to mobility outlined in the above Project Benefits section:		
<p>This project is the final push to create a fully connected non-motorized east/west route/pathway from Bryan Stock Trail to Robertson Rd. This route will serve users of all abilities and ages that seek safe and separate walking and cycling facilities to access work, school, retail, restaurants, and recreation sites. The pathway along Robertson Rd., completed in 2017, was an excellent stand along project that provided good residence to residence and residence to school access for people living in that area. However, a gap/missing link remains between the current terminus of the Platte River Trail in Paradise Valley and the Robertson Road trail. Currently the River Trail travels from Bryan Stock Trail, on Casper's east side, to Paradise Valley.</p>		

Safety:

Does this project provide a safety improvement?		<input checked="" type="checkbox"/> Yes <input type="checkbox"/> No <input type="checkbox"/> N/A
If yes, check all parties benefitted by the safety improvement:		
<input checked="" type="checkbox"/> Bicyclists		
<input checked="" type="checkbox"/> Pedestrians		
<input checked="" type="checkbox"/> Children		
<input checked="" type="checkbox"/> Elderly		
<input checked="" type="checkbox"/> People with Disabilities		
<input type="checkbox"/> Other:		
Will the project enhance awareness of cyclists and pedestrians outside of the project limits?		<input checked="" type="checkbox"/> Yes <input type="checkbox"/> No <input type="checkbox"/> N/A
Is the project within two (2) miles of a school and does it provide a safe connection between a residential community, the school, library, park, after-school activities, etc.?		<input checked="" type="checkbox"/> Yes <input type="checkbox"/> No <input type="checkbox"/> N/A
Describe the details of the safety improvements outlined in the above Safety section:		
<p>This project is a continuation of the PRTT and City's work to provide safe non-motorized transportation options for a wide range of users of all ages and abilities. Currently our community's River Trail terminates in Paradise Valley, so that any journey further west necessitates travel along CY Avenue/ Hwy. 220 to reach Robertson Rd. By extending the River Trail to Robertson, a wide range of users, including children, the elderly and people with disabilities, will be able to travel safely from the east Casper Soccer Complex, downtown Casper, the Library and other key locations to Casper's westside, Oregon Trail School and the neighborhoods along Robertson Rd.</p>		

Economic Opportunity:

Does the project improve economic opportunity by bringing more people to businesses?		<input checked="" type="checkbox"/> Yes <input type="checkbox"/> No <input type="checkbox"/> N/A
Does the project close a gap of existing walking/biking infrastructure to improve usability in a downtown, revitalization or business district?		<input type="checkbox"/> Yes <input type="checkbox"/> No <input type="checkbox"/> N/A
Provide details that substantiate answers outlined in the above Economic Opportunity section:		



This project builds on a project to be constructed in the summer of 2020, Morad Park to Mtn. View shopping center, to provide improved non-motorized access to shopping and businesses. Users from the Robertson Rd. area will now have non-motorized access to both the Mtn. View shopping center, that includes a bank, furniture store, a gym, food restaurants, big box stores and more, as well as all of the businesses and restaurants in downtown Casper.

Project Administration:

How will the project design and contract bidding documents be produced?

- Reimbursement for these activities will not be sought by the Sponsor.
- Sponsor Employed Engineer (Must be a full time employee of the Sponsor.)
- Consulting Engineer (To be selected after notification of project award and Notice to Proceed, as a result of a qualifications based selection.)

Who will review the project design and contract bid documents for the Sponsor?

- Reimbursement for these activities will not be sought by the Sponsor.
- Sponsor Employed Engineer (Must be a full time employee of the Sponsor.)
- Consulting Engineer (To be selected after notification of project award and Notice to Proceed, as a result of a qualifications based selection.)

Who will perform the construction management?

- Reimbursement for these activities will not be sought by the Sponsor.
- Sponsor Employed Engineer (Must be a full time employee of the Sponsor.)
- Consulting Engineer (To be selected after notification of project award and Notice to Proceed, as a result of a qualifications based selection.)

Brief Project Summary:

Outline the need for the project and the benefits of the project:

This project will achieve the Platte River Trail Trust and City of Casper’s long range goal to create a non-motorized route from Bryan Stock Trail to Robertson Road articulated in our CH2MHill Masterplan from August of 1982. The neighborhoods, and Oregon Trail school, located along Robertson Rd. are in the most western boundary of the City of Casper It is monumental to think that the City of Casper will be linked by a non-motorized route from east and west. This route links important community sites including Paradise Valley School, Mtn. View Shopping Center, Ft. Casper Museum, Pumphouse Trail Center, Downtown Casper, City Hall, The NIC, The Library, baseball fields, the Soccer Complex, the Boys & Girls Club and numerous parks on a safe and separate pathway. Users of all ages and abilities can now feel comfortable navigating east to west through the greater Casper community. In addition to the required grant match of \$125,000, the PRTT is committed to raising an additional \$375,000 from a variety of sources including the Natrona County Recreation Joint Powers Board and private and public foundations to complete this project as they have done for many other TAP funded projects over the past 30 years.



TAP Attachment B: Map
[INSERT UP TO TWO PAGES OF MAPS]
City of Casper



**CITY OF CASPER
PARADISE VALLEY TO ROBERTSON RD. TRAIL**

PROPOSED PATHWAY AND BRIDGE

DATE
JUNE 2020

FIGURE
EX 1.0





TAP Attachment C: Public Involvement/ Planning and Design Integration City of Casper

Is this project included in a planning document?

Yes No N/A

If Yes, provide the name and date of planning document:

Platte River Parkway Masterplan, August 1982

If Yes, List the groups that were/are involved in the planning:

Platte River Trails Trust Board, Friends of the Platte River Trails Trust, City of Casper

Have you discussed this project with your WYDOT District Engineer?

Yes No N/A

If Yes, indicate the date of the discussion and what was discussed:

On May 28, 2020 members of the Platte River Trails Board and representatives from the City of Casper Engineering Division met with the WYDOT District Engineer and other WYDOT Local Government staff on site to discuss the scope and benefits of the project.

Are there community concerns regarding this project?

Yes No N/A

If Yes, describe:

Does the project conform to all local ordinances, rules and regulations?

Yes No N/A

Are any variance approvals required?

Yes No N/A

What design standards have been, or are planned to be incorporated in the project design?

AASHTO PROWAG Wyoming Public Works WYDOT

Local Other (specify):

Provide a summary of the public involvement that has taken place previously for planning and design.

This project has been vetted by the Platte River Trails Trust (PRTT), PRTT Friends group, City of Casper staff and the general public. The PRTT is a volunteer led non-profit organization that works hand in hand with the City of Casper to develop our community's non-motorized active transportation network. The PRTT Board is comprised of 17 volunteers from a variety of professions as well as ex-officio members from Natrona County, Game & Fish, WY AG Extension and WYDOT. The PRTT applied for and was awarded City of Casper Optional One Cent #16 funds for this project. Optional One Cent #16 funds were approved by ballot in November of 2018. As part of the #16 One Cent grant process the PRTT provided City Council, City staff and the public



information about the project. In addition, the PRTT has an active public outreach effort that includes our website, e-newsletters, press releases as well as our Annual Meeting and Report. At our Annual Meeting the public is invited to speak and provide input on projects, such as the PV to Robertson Rd. bridge, on the PRTT drawing board. Information about our upcoming projects and initiatives is also available on our website, www.platterivertrails.com.



TAP Attachment D: Environmental Considerations

City of Casper

Does this proposed project have any unusual environmental features associated with it?

Yes No

If Yes, please describe:

The North Platte River is an environmental feature associated with this project. An Army Corps of Engineers permit will be necessary for construction. Construction will need to be performed during low water flow in the fall.

Are there any registered historic structures or sites involved with the project?

Yes No

If Yes, please describe:

Are there any live watercourses or bodies of water being encountered?

Yes No

If Yes, please describe:

The North Platte River. This project will involve a permit from the Army Corps of Engineers.



TAP: Project Estimating Worksheet (Infrastructure)

Project Sponsor :

City of Casper

Instructions:

- * Only input information in grey shaded areas below only.
- * Enter 0 in the percentages column if not seeking federal participation.
- * Only work performed after the execution of the State and Local agreement is eligible for federal reimbursement.
- * All requests will be rounded up to the nearest hundred dollars

Proposed Funding Match Rates	Local	Federal
	20.00%	80.00%

Infrastructure Project			Local Portion		Federal Portion	
Description (Include amounts for federal-aid items only)	Percentages	Project Totals	Proposed Local Match Percentage	Local Cash Match	Proposed Federal Percentage	Federal Amount Requested
Preliminary Construction Estimate or Estimated Total Cost of Planning		\$625,000.00	20.00%	\$125,000.00	80.00%	\$500,000.00
Construction Contingency 5% to 10% of PCE <i>(Quantity overruns, etc.)</i>	0.00%	\$0.00		\$0.00		\$0.00
Construction Engineering (Consultant) 0% or 10% of PCE <i>(Consultants shall be selected through established procedures)</i>	0.00%	\$0.00		\$0.00		\$0.00
Preliminary Engineering (Consultant) 0% to 15% of PCE <i>(Consultants shall be selected through established procedures)</i>	0.00%	\$0.00		\$0.00		\$0.00
Total Estimate (Infrastructure):		\$625,000.00		\$125,000.00		\$500,000.00

Total Project Estimate	Total Local Match	Total Federal Match
\$625,000.00	\$125,000.00	\$500,000.00



TAP Attachment F: Site Visit Form
[INSERT SITE VISIT FORM]
City of Casper

FY2021 TAP SITE VISIT CHECKLIST

Project Name: **Paradise Valley to Robertson Road Bridge**

Agency Type: **City/Town**

Agency Name: **City of Casper**

Contact Person: **Terry Cottenoir**

Contact Phone: **(307) 235-8341**

Contact Email: **tcottenoir@casperwy.gov**

Alternate Contact:

Agency Mailing Address: **200 N. David St. Casper, Wyoming 82601**

Joint Sponsor: **Platte River Trails Trust**

Joint Sponsor Contact: **Angela Emery, Executive Director**

LPA Certified Individual: **Yes**

Name of LPA Certified Individual: **Terry Cottenoir, Engineering Technician**

LPA Certification Expiration: **12/31/2020**

Project Location: **Paradise Valley, Casper, Wyoming**

Project Limits: **City property on Indian Paintbrush and Yarrow Street across the North Platte River to City property on Robertson Road near Little Moon Trail Road**

County: **Natrona**

Municipality: **City of Casper**

Project Length: **The project will include 1090 ft. of concrete pathway from Indian Paintbrush Road to the bridge, a bridge spanning the North Platte River approximately 276 ft. long and 75 ft. of pathway connecting the bridge to the Robertson Road pathway.**

Project Type: **ADA Compliance; ADA Upgrades; ADA Transition Plans, Safe Routes for Non-Drivers, Pedestrian & Bicycle Facilities, N/A, Scenic Turnouts and Overlooks**

Is the project included in a planning document: **Yes - please explain below**

WYDOT District Engineer aware of project: **Yes - please explain when and what you discussed below**

If you selected "Yes," explain: **Yes. This project has been discussed on several occasions with the WYDOT District Engineer along with other projects on the Platte River Trails and City of Casper active transportation drawing board.**

Project Description: **The proposed project is Phase I of a two-phased project to extend the spine of Casper's non-motorized transportation system, the Platte River Trail, west from its current terminus in Paradise Valley to the many neighborhoods and schools along Robertson Road in west Casper. Currently the Platte River Trail travels from Bryan Stock Trail on the east side of Casper to Paradise Valley Park. An extension of the Platte River Trail further west is part of an ongoing effort to safely connect more neighborhoods to our spine trail to improve active transportation access to businesses, schools, parks and other key destinations. This project builds on a current TAP funded project by the Platte River Trails Trust**

and City of Casper to connect the Platte River Trail to the Mountain View Shopping Center along CY Avenue.

Does the Sponsor Own the Land: Yes

Who owns the affected land?: City/Town

Milestone Dates:

Environmental Clearance, Preliminary Engineering Completed by:	Final Engineering and Bid Documents Completed by:	Project Bidding by:	Begin Construction by:	Construction Complete by:
6/30/2020	3/1/2021	4/15/2021	10/1/2021	11/30/2021

Potential delays in reaching milestones: Construction of the bridge will need to occur during the low flow period for the North Platte River and before winter arrives which is typically early to late fall.

Local Match Amount: 125000
 Source of Match: Funding will be from the City of Casper One Cent #16 Optional Sales Tax Fund.
 TAP Requested Amount: 500000
 Total Cost: 625000

Fiscal Year	Open Project
2016	No
2017	No
2018	Yes
2019	Yes

Open Project Numbers: CD 19201 – Morad to Walmart Trail
 CD 20202 - Midwest Ave. Bike Lane and Pedestrian Development

Is the applicant an eligible sponsor?	X Yes	No
Has the applicant previously completed a federal aid project?	X Yes	No
Does the applicant acknowledge that receipt of funds requires compliance with several federal and state requirements, including but not limited to wage, equal opportunity, and environmental requirements?	X Yes	No

PEDESTRIAN/BICYCLE FACILITIES (IF APPLICABLE)

Facility description	Sidewalk	Sidewalk with curb and gutter	Pathway
	X Shared use pathway	Sharrow	Striped bicycle lane
	Widened shoulder	ADA Upgrades	Other
Width of pathway, bicycle lane, shoulder, etc.:	10'	Length:	1500'
Distance from curb (for pathways):	N/A		
Proposed Materials:	Asphalt X Concrete	Multi-Use Pathway	Single Track Other
Number of curb ramps:	0		
Proposed Design Standards:	X AASHTO	PROWAG	Wyoming Public Works
	WYDOT	Local	Other:
This project is:	Part of road widening	X Part of an existing road	X Away from roadways
Are there any areas where the facility will narrow to accommodate trees, signs or other obstructions? If yes, explain:			Yes X No
What is the plan for maintaining the facility after construction is complete?			
City of Casper will be responsible for maintenance.			
Does your community normally require sidewalks or other pedestrian/bicycle improvements as a condition of subdivision or site plan approval? Explain:			X Yes No
RIGHT-OF-WAY			
Does the sponsor possess the necessary right-of-way to construct the project? If not, explain how right-of-way will be acquired.			X Yes No
Is there a rail line or railroad property near the proposed project?			Yes X No
Does the sponsor hold necessary easements to construct the project? If not, explain how easements will be obtained.			X Yes No
ENVIRONMENTAL			
Does it appear that the project will meet the environmental criteria for Categorical Exclusion?			X Yes No
Does it appear that the proposed project will require extensive cultural clearance?			Yes X No
Does it appear that supplemental environmental documentation will be required to support a Categorical Exclusion determination?			X Yes No
For example: Wetlands Endangered Species X Other: Bridge over river. USACE			
Does it appear that the project will cause an adverse effect to environmental resources? If yes, explain:			Yes X No
Are there any permitting requirements for the project? If yes, explain:			X Yes No
USACE			
UTILITIES			
Is it apparent that the project will have utility conflicts? If yes, explain and identify affected utilities and how conflicts will be mitigated.			Yes X No

--

IRRIGATION

Does it appear that the project will have crossings or conflicts with irrigation facilities? If yes, explain and identify affected irrigation facilities and how conflicts will be mitigated.

Yes No

--

Comments:

Applying for construction only. Design and environmental will be completed in-house.

Statement of Intent Submitted by: Angela Emery, Executive Director, Platte River Trails

Date of Submission: 4/13/2020 14:37:27

Site Visit Review Completed by: __Dave, Sara, Leanna and Mark Ayen__

Printed Name: _____

Date of Site Visit: __5-14-2020__



TAP Attachment G: *Resolution*

[INSERT Resolution]

City of Casper

RESOLUTION NO. _____

A RESOLUTION AUTHORIZING SUBMISSION OF AN APPLICATION TO THE WYOMING DEPARTMENT OF TRANSPORTATION FOR THE FISCAL YEAR 2021 TRANSPORTATION ALTERNATIVES PROGRAM FUNDING FOR THE PARADISE VALLEY TO ROBERTSON ROAD BRIDGE PROJECT.

WHEREAS, the City of Casper desires to construct a pedestrian bridge and ten foot (10') wide concrete pathway connections to the Robertson Road Pathway and the neighborhoods of Paradise Valley; and,

WHEREAS, the Transportation Alternatives Program (TAP) is a federally funded program that is intended to fund projects that will enhance transportation safety, especially for non-motorized transportation enhancements; and,

WHEREAS, the TAP program requires that federal funding criteria be met, and the City of Casper agrees to ensure satisfaction of all requirements; and,

WHEREAS, the City of Casper acknowledges that if funded, the TAP project shall be completed by December 31, 2023; and,

WHEREAS, the City of Casper agrees to set aside a minimum of One Hundred Twenty-Five Thousand Dollars (\$125,000.00) as a line item in its budget for the required twenty percent (20%) local cash match on the project; and,

WHEREAS, the City of Casper acknowledges TAP is funded on a reimbursement basis and all invoices must be one hundred percent (100%) paid by the City of Casper prior to reimbursement through TAP (eighty percent (80%) Federal Reimbursement). The City of Casper acknowledges that failure to comply with this requirement may result in cancellation of the award and repayment by the City of Casper of all funds reimbursed.

NOW, THEREFORE, BE IT RESOLVED BY THE GOVERNING BODY OF THE CITY OF CASPER, WYOMING: That the Mayor is hereby authorized to execute an "Application for Transportation Alternatives Program (TAP) Funding" in the amount of Five Hundred Thousand Dollars (\$500,000.00) for Fiscal Year 2021.

BE IT FURTHER RESOLVED: That the City Engineer or his designee is hereby authorized to submit the TAP grant to the Wyoming Department of Transportation for processing.

PASSED, APPROVED, AND ADOPTED this ____ day of _____, 2020.

APPROVED AS TO FORM:

ATTEST:

CITY OF CASPER, WYOMING
A Municipal Corporation

Fleur Tremel
City Clerk

Steven K. Freel
Mayor



TAP Attachment H: Lobbying Certificate

Lobbying Certification Statement

The undersigned City of Casper certifies, to the best of his or her knowledge and belief, that:

- (1) No Federal appropriated funds have been paid or will be paid, by or on behalf of the undersigned, to any person for influencing or attempting to influence an officer or employee of an agency, a Member of Congress, an officer or employee of Congress, or an employee of a Member of Congress in connection with the awarding of any Federal contract, the making of any Federal grant, the making of any Federal loan, the entering into of any cooperative agreement, and the extension, continuation, renewal, amendment, or modification of any Federal contract, grant, loan, or cooperative agreement.
- (2) If any funds other than Federal appropriated funds have been paid or will be paid to any person for making lobbying contacts to an officer or employee of any agency, a Member of Congress, an officer or employee of Congress, or an employee of a Member of Congress in connection with this Federal contract, grant, loan, or cooperative agreement, the undersigned shall complete and submit Standard Form--LLL, "Disclosure Form to Report Lobbying," in accordance with its instructions [as amended by "Government wide Guidance for New Restrictions on Lobbying," 61 Fed. Reg. 1413 (1/19/96). Note: Language in paragraph (2) herein has been modified in accordance with Section 10 of the Lobbying Disclosure Act of 1995 (P.L. 104-65, to be codified at 2 U.S.C. 1601, et seq .)]
- (3) The undersigned shall require that the language of this certification be included in the award documents for all subawards at all tiers (including subcontracts, subgrants, and contracts under grants, loans, and cooperative agreements) and that all subrecipients shall certify and disclose accordingly.

This certification is a material representation of fact upon which reliance was placed when this transaction was made or entered into. Submission of this certification is a prerequisite for making or entering into this transaction imposed by 31, U.S.C. § 1352 (as amended by the Lobbying Disclosure Act of 1995). Any person who fails to file the required certification shall be subject to a civil penalty of not less than \$10,000 and not more than \$100,000 for each such failure.

[Note: Pursuant to 31 U.S.C. § 1352(c)(1)-(2)(A), any person who makes a prohibited expenditure or fails to file or amend a required certification or disclosure form shall be subject to a civil penalty of not less than \$10,000 and not more than \$100,000 for each such expenditure or failure.]

The Project Sponsor certifies or affirms the truthfulness and accuracy of each statement of its certification and disclosure, if any. In addition, the Sponsor understands and agrees that the provisions of 31 U.S.C. A 3801, et seq., apply to this certification and disclosure, if any.

Signature

Terry Cottenoir, Engineering Technician

6/4/2020

Date



TAP Attachment I: Right-of-Way City of Casper

Local Public Agency Right-of-Way & Utility Certificate

Local Public Agencies (LPAs) are required to submit proof of the following to WYDOT.

City of Casper hereby certifies to the Wyoming Department of Transportation and the Federal Highway Administration that:

The acquisition of Right-of-Way was not required. All work proposed is within Right-of-Way obtained or acquired prior to programming this project.

OR

All necessary rights-of-way have been acquired including legal and physical possession in accordance with all applicable laws and regulations noted below. No persons of business have been or will be displaced by this project. All requirements of 23 CFR 635.309(b)(c)(g)&(h). Authorization, 49 CFR Part 24 – Uniform Relocation Assistance and Real Property Acquisition for Federal and Federally Assisted Programs, and the Wyoming Relocation Assistance Act of 1973, Sections 16-7-101 through 16-7-121.

Utility relocations/adjustments are not required for completion of this project.

OR

Utility relocations/adjustments within the project limits of construction have been completed, or are incorporated in the contract plans as biddable work.

There is no work involving railroad right-of-way for the completion of this project.

OR

All necessary arrangements have been made for railroad work to be completed as required for proper coordination with the construction.

This undersigned certifies the above information is accurate as of the date below:

Signature

Terry Cottenoir, Engineering Technician

6/4/2020

Date



LPA Attachment J: Internal Review's Risk Assessment

City of Casper

Have there been any key personnel Changes in the direct implementation and administration of grant awards during the previous year? (Key personnel include the project administrator, accounting, budget, or controller personnel) [2 CFR 200.331(a)(6)(3)] Yes No

Has the organization as a whole (Re: Personnel) remained unchanged during the previous year? Yes No

Has the accounting/financial system remained the same as last year? Yes No

If No, explain:

Does your entity receive federal grant money **directly** from any federal awarding agencies (FTA, FHWA, NHTSA, etc.)? These monies do not have any WYDOT involvement for applications, payments, etc. [2 CFR 200.331(a)(6)(4)]. Yes No

Has a federal agency monitored, inquired or been directly involved in outstanding award(s)? Yes No

Has a federal agency ever performed a review or audit of outstanding award(s)? Yes No

If Yes, did the federal agency determine that there were no financial or compliance issues? Yes No

If No, provide a description of the financial and/or compliance issues as detailed by the federal agency: A single audit finding stated that one employee who performs activities under the grant also works on activities which are not related to the Federal award. A time log was maintained by this employee; however, 100% of the employee's time was inadvertently charged by the payroll system to this federal award. The City of Casper's corrective action is to educate MPO staff on the procedures for personnel cost allocation between grant funded and non-grant funded lines. The City communicated with the federal funding authority to ensure that the the previous overpayments have been dealt with appropriately so that the grant can be brought back into compliance. The City will institute ongoing monitoring to ensure continued compliance with grant regulations.

The Wyoming Department of Transportation's Internal Review agreed with the City's audit response and no further information was requested in a letter to Pete Meyers, Assistant Financial Services Director, dated August 9, 2017.

Does your entity have written procedures for procurement transactions? [2 CFR 200.313-318] Yes No

Does the Sponsor anticipate requesting reimbursement through the project for Indirect Cost? Yes No

(Indirect [F&A] costs means those costs incurred for a common or joint purpose benefitting more than one cost objective, and not readily assignable to the cost objectives specifically benefitted, without effort



disproportionate to the results achieved. To facilitate equitable distribution of indirect expenses to the cost objectives served, it may be necessary to establish a number of pools of indirect [F&A] costs. Indirect [F&A] cost pools must be distributed to benefitted cost objectivevs on bases that will produce an equitable result in consideration of relative benefits derived.) [2 CFR 200.56]

Does the Sponsor have an Approved Indirect Cost rate with WYDOT?

Yes No N/A

If No, does the Sponsor propose using the de minimis rate of 10%?

Yes No N/A



Attachment K – Consultant Services Policy

Updated 09-20-17

CONSULTANT SERVICES POLICY

City of Casper

June 3, 2020

SECTION I. INTRODUCTION

This policy establishes procedures of the *City of Casper* for the procurement, management, and administration of consultant services required for a project using federal or non-federal funds obtained through the Wyoming Department of Transportation (WYDOT). This policy and procedures will be followed when hiring consultants to supplement the *City of Casper* personnel or to provide other professional services that the *City of Casper* determines can be best completed by qualified private-sector firms.

Consultant, as used in this document, means engineering firms, architectural firms, survey firms, educational institutions, and other firms or individuals engaged in providing consulting or other professional services. *Subconsultant*, as used in this document, means an individual or firm contracted by the consultant to provide related services.

Simplified Acquisition Threshold (SAT), as used in this document, means the dollar amount at or below which a government entity may purchase services using small agreement/purchase methods. The SAT is currently \$150,000, but this threshold is periodically adjusted for inflation. (48 CFR 2.101)

Architectural and Engineering (A & E) services are defined to mean:

1. Professional services of an architectural or engineering nature, as defined by state statute, which are required to or may logically or justifiably be performed or approved by a person licensed, registered, or certified to provide related services.
2. Professional services of an architectural or engineering nature, performed by consultant agreement, and associated with research, planning, development, design, construction, alteration, or repair of real property.
3. Professional services of an architectural or engineering nature, which a firm or individual within the engineering or architectural professions would perform, such as studies, investigations, survey and mapping, tests, evaluations, consultations, comprehensive planning, program management, conceptual designs, plans and specifications, value engineering, construction phase services, soils engineering, drawing reviews, preparation of operating and maintenance manuals, and other related services.

Architectural and Engineering services that directly lead to development of a construction project are defined and limited to:

1. Preparation of roadway/bridge contract documents including preliminary through final design, contract plans, specifications, and incorporated engineering drawings, details, and estimates.
2. Completion of surveys and mapping necessary for preparation of roadway/bridge contract documents.
3. Completion of architectural services directly leading to facility construction.
4. Completion of feasibility studies when used for project planning leading to project construction.
5. Construction project management including contract administration and construction engineering.
6. Completion of consultant services not clearly within (1) thru (5) above, which must be performed or approved in accordance with state law by a registered professional (i.e. engineer, land surveyor, architect, geologist, etc.).
7. The final cost of these services, including the original agreement cost and subsequent agreement modifications, must exceed the SAT.

SECTION II. CONSULTANT PROCUREMENT – GENERAL

Two methods for procuring consultant services are available for use depending on administrative controls which consider the estimated cost of the proposed services.

Consultant services with an estimated cost at or less than the SAT (Small Agreement) will be procured using a simplified procurement process presented in SECTION IV(A) – Small Agreement – Estimated Cost at or less than the SAT.

Consultant services with an estimated cost exceeding the SAT (Large Agreement) will be procured using a formal request for proposal (RFP) process as presented in SECTION IV(B) – Large Agreement – Cost greater than the SAT.

SECTION III. CONSULTANT NEED AND OTHER SUPPORTING INFORMATION

The *City of Casper* will develop supporting information to establish the need for consultant services and identify the procurement method, selecting one of the procurement methods

outlined in SECTION IV – CONSULTANT PROCUREMENT PROCESSES. Supporting information should be tailored to the procurement method and include the following:

A. Small Agreement – Estimated Cost at or less than the SAT

Small agreements, developed consistent with SECTION IV(A) – Small Agreement – Estimated Cost at or less than the SAT, should include the following supporting information:

1. A statement supporting the use of a consultant to perform work due to unique capabilities not readily available within the *City of Casper* or that *City of Casper* personnel are not available to complete the necessary work or meet proposed schedules.
2. A preliminary scope of work for the proposed services.
3. A schedule for completion of work to be performed by the consultant.
4. A funding source for the required consultant services.
5. A preliminary cost estimate.
6. The agreement type to be used as the basis of compensation (See SECTION VI – AGREEMENT TYPE, BASIS FOR COMPENSATION, PAYMENT).

B. Large Agreement – Cost greater than the SAT

Large agreements, developed consistent with SECTION IV(B) – Large Agreement – Cost greater than the SAT, require that consultant services be procured through a request for proposal. The supporting information for these services should include the following:

1. A statement supporting the use of a consultant to perform work due to unique capabilities not readily available within the *City of Casper* or that *City of Casper* personnel are not available to complete the necessary work or meet proposed schedules.
2. A preliminary scope of work for the proposed services.
3. A schedule for completion of work to be performed by the consultant.
4. A funding source for the required consultant services.

5. A preliminary cost estimate. See SECTION IV(B) – Large Agreement – Cost greater than the SAT.
6. The agreement type to be used as the basis of compensation (See SECTION VI – AGREEMENT TYPE, BASIS FOR COMPENSATION, PAYMENT).
7. Consultant selection by the selection committee. Selection committee members should be identified by name and title.
8. A listing of evaluation factors and weighting factors for the ranking and selection of a qualified consultant firm. The use of evaluation factors and weighting factors should be tailored to the procurement process; the number of evaluation factors can be limited and the use of weighting factors can be limited or eliminated. The selected factors should assess the consultant’s qualifications and competency, tailored to the proposed type/scope of work and any anticipated work types. Evaluation factors **may** consider:
 - a. Established expertise;
 - b. Related work experience in a responsible role;
 - c. Qualifications of the firm’s personnel;
 - d. Previous performance on *City of Casper* projects;
 - e. Project understanding/knowledge, including proposed approach to completing project work;
 - f. Workload capacity;
 - g. Ability to meet project schedule;
 - h. Specialized expertise or product delivery requirements (such as computer hardware or software);
 - i. Other evaluation factors relating to the specific project may be used.

Evaluation factors that cannot be used on federal funded A & E services include:

- a. Cost components – consultant fee proposal, direct salaries/wages, other direct costs, or indirect cost rates;

- b. In-state or local preferences.

Cost, as one evaluation factor, may be used on federal funded non-A & E services.

The selection committee should note that two specific non-qualification-based evaluation factors may be used, if appropriate, but together cannot exceed 10% of the total weighted evaluation. These two factors, directed to an individual proposed project, are:

- a. A local presence, where that presence will add value to the quality or efficiency of project delivery, but will still allow for the consideration of a sufficient number of qualified firms;
- b. The participation of qualified and WYDOT-certified Disadvantaged Business Enterprise (DBE) consultants or subconsultants. The *City of Casper* should coordinate with the WYDOT Civil Rights Office to obtain a current listing of DBE consultants.

The need/use of a consultant firm in a management role for the *City of Casper* will require approval by WYDOT and FHWA before consultant solicitation. (23 CFR 172.7(b)(5))

SECTION IV. CONSULTANT PROCUREMENT PROCESSES

Two methods for procuring consultant services are available for the *City of Casper* use. The use of each method is limited depending on the estimated cost of the proposed services; these administrative controls are presented as an introductory paragraph to each procurement method/agreement type.

A. Small Agreement – Estimated Cost at or less than the SAT

The use by the *City of Casper* of a small agreement is limited to consultant services with an estimated cost at or less than the SAT, including the original agreement cost and subsequent agreement modifications. Small agreements can be used for non-federal and federal funded services, and for A & E and non-A & E services.

A preliminary cost estimate will be prepared for use as required in SECTION VIII – NEGOTIATING THE FINAL AGREEMENT AND COST PROPOSAL.

The *City of Casper* will make an informal consultant selection utilizing a consultant list obtained from WYDOT Engineering Services or a list generated by the *City of Casper*. A minimum of three consultants must be evaluated leading to a qualification-based

selection. The evaluation should use information available from the consultant's Statement of Interest, and if needed, that information can be supplemented with interviews, or written or oral discussion with each firm.

If less than three qualified consultants are available, the *City of Casper* will proceed with evaluation and selection when assured that the selected consultant has the minimum qualifications to complete the agreement type of services and has the experience necessary to satisfactorily perform the required services.

The basis for selection will be documented. The following items should always remain under consideration to conclude that a consultant firm has the minimum qualifications to complete the proposed project scope of work:

1. The consultant shall have an exemplary ethical and professional reputation.
2. The consultant's employees shall have levels of education, training, and experience necessary to perform the required services satisfactorily.
3. Professional services provided to the *City of Casper* require that the consultant employee overseeing the work and the consulting firm be licensed, if required by the applicable State Board.
4. The consultant shall be established in the area of expertise for which the firm is being considered, with recent work experience in a responsible role.

After the consultant selection, the *City of Casper* shall follow procedures outlined in SECTION V – APPROVAL OF CONSULTANT prior to proceeding with the process of negotiating the agreement with the selected consultant.

A detailed scope of work shall be prepared, often by the selected consultant. The consultant shall submit a fee proposal including proposed billing rates, estimated units of work, and the total proposed fee. The *City of Casper* will negotiate and prepare an agreement for execution.

Execution of the agreement will follow procedures outlined in SECTION X – EXECUTION OF THE AGREEMENT.

B. Large Agreement – Cost greater than the SAT

The use by the *City of Casper* of a large agreement is required for consultant services with an estimated cost greater than the SAT, including the original agreement cost and

subsequent agreement modifications. Large agreements can be used for non-federal and federal funded services, and for A & E and non-A & E services.

When the *City of Casper* requires consultant services and proposes to use this large agreement, the following requirements apply.

A preliminary cost estimate will be prepared for use as required in SECTION VIII – NEGOTIATING THE FINAL AGREEMENT AND COST PROPOSAL. For architectural and engineering services directly leading to construction, as defined in SECTION I – INTRODUCTION, the cost estimate must establish major elements of agreement costs: labor hours by work type and classifications of labor, direct salaries by labor classifications, other direct costs, anticipated indirect cost rates, and anticipated fixed fees (profit). This estimate will be used as the basis for negotiation. For all other services, the preliminary cost estimate can be less formal.

The *City of Casper* will direct the procurement process in coordination with the WYDOT Local Government Office and an appointed selection committee.

An early action will be to appoint participants to a selection committee. The committee should consist of at least three members, but generally not more than five members. The *City of Casper* should select committee members who can best evaluate consultant qualifications, but without previous experiences that could potentially influence their actions leading to a conflict of interest. Each committee member will ensure that he or she has no possible conflict of interest that may influence the evaluation, ranking, and selection process. If a conflict of interest may exist, the committee member will be excused from serving on the committee.

A pre-selection meeting will be conducted to establish the requirements of the RFP and the public announcement/advertisement to be used to assure that consultants have fair opportunity to be considered for award of the agreement.

The *City of Casper* may solicit project-specific letters of interest through a public announcement, public advertisement, or any other public forum or method (such as soliciting firms on a consultant list obtained from WYDOT Engineering Services) that assures qualified in-State and out-of-State consultants are given a fair opportunity to be considered. A minimum seven-day announcement period is required.

The selection committee will determine a short list of firms from the respondents to the public announcement/advertisement to receive the RFP. If enough firms respond, a minimum of five firms should be short-listed.

Alternatively, the *City of Casper* may go directly to the RFP process and consider all the proposals submitted.

The RFP will include the following requirements and information to provide direction for the content of consultant proposals. The RFP requirements and information will not include any condition that would limit competition and the resulting number of proposals.

1. Detailed scope of work, including a preliminary project purpose and description.
2. Technical requirements: specific services; deliverables; applicable policies and guides; proposed standards, criteria, specifications, or contracting requirements; proposed schedule for completion of agreement work.
3. Evaluation and weighting factors to be used for the ranking and selection based on consultant competency and qualifications.
4. The anticipated schedule leading to consultant selection. The schedule should identify consultant submittal dates using a minimum of 14 calendar days from issuance of the RFP, but set to assure that interested firms have sufficient time to receive the RFP, and prepare and submit a proposal.
5. The type of agreement to be used and the basis for compensation.
6. Address potential discussions with interested firms after submittal of their proposal, if any, directed to clarification of technical requirements or approach, qualifications, or capability. Based on the size and complexity of the project, it may be beneficial to the selection committee to have one-on-one discussions with all or some of the qualified firms (minimum of three). The intent and structure of these discussions, if needed, should be outlined in the RFP.
7. Consultant proposal shall include additional submittals concerning proposed subconsultants.
8. Consultant cost proposals, if requested, should be included in a concealed format that is clearly separate from the technical proposal.

The RFP should provide an adequate number of consultant proposals. When three or more qualified firms respond, the *City of Casper* will proceed with consultant ranking and selection. If less than three firms respond, the *City of Casper* may proceed with ranking and selection of a qualified firm or may elect to re-distribute the RFP in an attempt to gain additional proposals. In the event the response to an RFP does not result in either qualified or competitive firms, the *City of Casper* may pursue other contracting

options, including non-competitive, to procure professional services. The *City of Casper* will coordinate with the WYDOT grant administrator prior to non-competitive selection of a consultant.

After receipt of consultant responses to the RFP, the final selection meeting will be held. The selection process will include a series of actions taken by the *City of Casper*.

1. Review RFP proposals to assure they are complete.
2. Distribute the supporting information outlined in SECTION III(B) – Large Agreement – Cost greater than the SAT, to include the RFP, all consultant proposals, and each consultant’s Letter of Interest, if applicable.
3. Assist the selection committee, as needed, to complete the evaluation, ranking, and selection process.
4. Notify, subsequent to consultant selection, all consultants responding to an RFP of the final ranking of the three most highly qualified consultants.
5. Properly dispose as necessary, subsequent to consultant selection, the concealed cost proposals of the unsuccessful consultant firms.
6. Retain documentation supporting the solicitation, RFP, proposals, evaluation, and selection of the consultant firm.

The selection committee completes the evaluation and selection process by using the supporting information for each evaluation factor and then developing an overall score and subsequent ranking. The committee must rank in order of preference at least the three most highly qualified firms, leading to final selection. If less than three qualified firms respond to the RFP and it is concluded that the responding firms represent those firms available to meet the requirements of the RFP, the evaluation and selection will be completed.

The selection committee may not use a consultant’s cost components – consultant fee proposal, direct salaries, direct costs, and indirect cost rates – as a factor in the evaluation, ranking, or selection process for federal funded A & E services. Federal funded non-A & E services may, or may not, use cost as an evaluation factor.

The following items should always remain under consideration to conclude that a consultant firm has the minimum qualifications to complete the proposed project scope of work:

1. The consultant shall have an exemplary ethical and professional reputation.
2. The consultant's and subconsultant's employees shall have levels of education, training, and experience necessary to perform the required services satisfactorily.
3. Professional services provided to the *City of Casper* require that the consultant employee overseeing the work and the consulting firm be licensed, if required by the applicable State Board.
4. The consultant shall be established in the area of expertise for which the firm is being considered, with recent work experience in a responsible role.

During this process, an unqualified consultant firm may be dismissed from further consideration.

After the consultant selection, the *City of Casper* shall follow procedures outlined in SECTION V – APPROVAL OF CONSULTANT prior to proceeding with the process of negotiating the agreement with the selected consultant.

The final scope of work may be refined through negotiations with the selected consultant. The consultant shall submit a fee proposal including proposed billing rates, estimated units of work, and the total proposed fee. The *City of Casper* will negotiate and prepare an agreement for execution.

Execution of the agreement will follow procedures outlined in SECTION X – EXECUTION OF THE AGREEMENT.

SECTION V. APPROVAL OF CONSULTANT

After the selection committee or the *City of Casper* authorized representative has completed the procurement process, the *City of Casper* shall submit, in writing, the selected consultant's name to the WYDOT grant administrator for approval. The WYDOT grant administrator's approval authorizes the process of negotiating the agreement with the selected consultant.

The WYDOT grant administrator will initiate a pre-negotiation audit, if necessary (see SECTION VII – PRE-NEGOTIATION AUDIT EVALUATION).

The *City of Casper* will maintain a correspondence file for each consultant services agreement documenting all aspects of the selection and approval process.

SECTION VI. AGREEMENT TYPE, BASIS FOR COMPENSATION, PAYMENT

Contractual requirements and the method of payment to direct and compensate the consultant will be established by agreement. An agreement type and basis for compensation will be selected as the need for consultant services is developed, as presented in SECTION III – CONSULTANT NEED AND OTHER SUPPORTING INFORMATION.

- A. **Agreement Types.** An agreement type will be selected by the *City of Casper*.
1. **Project Specific.** This will be used with a defined scope of work and the related consultant services when these services are directed to one or more specific projects.
 2. **Multi-Phase.** This can be used, similar to Project Specific, when the *City of Casper* determines that a consultant's services should be divided into defined phases to gain better definition of the scope of work and related consultant services. Each phase would require a separate cost estimate.
- B. **Basis for Compensation.** The method of payment to compensate the consultant will be specified in the agreement. It may establish a single method for all work or may be better administered with different methods for different elements of work.
1. **Cost Plus Fixed Fee.** Cost reimbursement includes actual costs payable for direct labor and indirect labor (overhead) as established in the agreement, plus direct reimbursable expenses. Cost reimbursement also includes a negotiated fixed fee, established in the agreement, and is calculated to cover the consultant's profit. Billing rates established in the agreement shall be used for all billings and a maximum amount payable will be established.

Cost plus percentage of cost and percentage of construction cost cannot be used as a basis for compensation.
 2. **Lump Sum.** May only be used when the scope of work and the duration of work can be accurately established, and an estimate of cost, including fixed fee, can be calculated with reasonable accuracy at the time of negotiation with the selected consultant.
 3. **Unit of Work.** May be used when a unit cost of work can be determined in advance with reasonable accuracy, but the extent of work is indefinite. Quantities and characteristics of each unit should be uniform, and a maximum amount payable will be established.

4. **Specific Rates for Compensation.** The specific rates for compensation will provide for reimbursement on the basis of direct labor hours at specified fixed hourly rates, including direct labor costs, indirect costs, and profit, plus any other direct expenses or costs. This method of payment will be used for those types of services and agreements that establish a maximum amount payable and provide the *City of Casper* direct control of the number of consultant labor hours and resultant cost.

Specific Rates may also be used when a consultant's services are required to perform work that cannot be estimated for extent, duration, or cost.

Consistent with all consultant agreements, a *City of Casper* representative will monitor the consultant's performance of services to include labor hours, and classification/pay rate of consultant employees used to perform agreement services.

- C. **Consultant Payments and Retainage:** Periodic progress payments will be made for work satisfactorily completed based on invoice submittals to the *City of Casper*.

All agreements shall include provisions that require the consultant to make prompt payment to subconsultants within 30 calendar days from receipt of payment from the *City of Casper* (49 CFR 26.29). These provisions will advise the consultant to be prepared, if requested, to provide documentation that payment has been made for work satisfactorily completed by a subconsultant. These provisions will also notify the consultant that failure to make prompt payment may be addressed by the *City of Casper* as presented in the written procedures in ATTACHMENT 2 – BREACH OF AGREEMENT.

The *City of Casper* may withhold retainage from payments, including final payment, if specified in the agreement.

SECTION VII. PRE-NEGOTIATION AUDIT EVALUATION

Pre-negotiation audits are generally performed on first-time consultants, consultants with outdated audits, or as required by WYDOT Internal Review Services. A risk assessment will be performed by WYDOT Internal Review Services to determine if an audit is required and, if so, the type of audit required. An audit report or comparable correspondence will be provided by WYDOT Internal Review Services to the *City of Casper* for use in negotiating the consultant agreement.

SECTION VIII. NEGOTIATING THE FINAL AGREEMENT AND COST PROPOSAL

Approval of the selected consultant in accordance with SECTION V – APPROVAL OF CONSULTANT authorizes the process of negotiating the agreement and cost proposal with the selected consultant.

The *City of Casper* will work with the consultant to finalize the scope of work, if needed, and initiate negotiations with the consultant for a final cost proposal. A draft agreement, including the scope of work, is provided to the consultant with instructions for preparing the cost proposal. The consultant is advised at the beginning of negotiations that selection is subject to arriving at a satisfactory agreement for terms and fees, and that the *City of Casper* assumes no obligation to the consultant until the agreement is executed.

The consultant's use of subconsultants is allowed only with written approval from the *City of Casper* of the proposed subconsultants. The consultant shall describe the work to be done by the subconsultant in the fee proposal, assure incorporation of required agreement provisions into the subconsultant agreement (SECTION IX – AGREEMENT PROVISIONS) and include a cost for the subconsultant's proposed work. The *City of Casper* may request a detailed proposal for subconsultant work to include proposed labor rates and direct costs. The cost proposal and included rates will be evaluated for reasonableness. If the subconsultant has a WYDOT-approved audit or approved billing rates, those rates shall be used.

A consultant's fee proposal will be compared to the cost estimate done by the *City of Casper*, including careful attention to proposal details. The consultant's fixed fee (profit) will be negotiated separate from other negotiations.

The consultant's or subconsultant's proposed indirect cost rate shall be certified by each firm's chief executive or financial officer as being allowable in accordance with federal cost principles. Each firm's certification shall read as required by WYDOT Internal Review Services.

A consultant's schedule for completing the work, if different from the schedule proposed by the *City of Casper*, will be reviewed to assure that the established duration of the agreement permits completing the work in a time frame acceptable to the *City of Casper*. When the consultant's fee proposal and the duration of the agreement are acceptable, the agreement is finalized and executed.

If the consultant's proposed fee or schedule varies substantially from the estimate or schedule of the *City of Casper*, the items of variance are identified and discussed to resolution. After agreeing on the agreement terms and fees, the consultant submits a final cost proposal.

The *City of Casper* will maintain documentation of the negotiation process.

If the selected consultant and the *City of Casper* cannot reach a satisfactory agreement, the *City of Casper* will cease negotiations and notify the consultant and the WYDOT grant administrator. The *City of Casper* will then initiate negotiations with the next highest ranked consultant or, at its option, initiate a new procurement process.

SECTION IX. AGREEMENT PROVISIONS

The *City of Casper* will determine the consultant agreement type, the basis for compensation, terms of the agreement, and the required provisions, clauses, assurances, and/or certifications to ensure compliance with state and federal laws, regulations and requirements.

Each agreement will:

1. Name the authorized representative of the *City of Casper*.
2. Outline the representative's administrative responsibilities.
3. Identify the project location.
4. Present the scope of work and consultant deliverables.
5. Provide for applicable plans and specifications.
6. Authorize commencement of work.
7. Specify fees and payments based on consultant's progress reports.
8. Specify completion of work by number of calendar days or the calendar date by which all required services shall be completed.

Each agreement will outline data, services, and obligations of the *City of Casper* as related to the consultant's performance of required services.

Federal General Provisions will be physically incorporated or incorporated by reference into consultant agreements funded with federal funds. These Provisions will apply to the consultant and all subconsultants engaged by the consultant. ATTACHMENT 1 – FEDERAL GENERAL PROVISIONS presents applicable Federal General Provisions and administrative procedures.

ATTACHMENT 2 – BREACH OF AGREEMENT presents written procedures to administer breach of the agreement.

The *City of Casper* reserves the right to terminate any agreement, as described in the agreement. In this event, compensation is made to the consultant based upon the progress of the work performed prior to termination. Work performed shall be defined as the deliverables specified in the agreement and accepted by the *City of Casper*, and not the labor hours billed. The *City of Casper* will notify the consultant, in writing, of agreement termination.

SECTION X. EXECUTION OF THE AGREEMENT

The *City of Casper* will prepare the final agreement for execution by all parties.

Agreements will conform to the state contract requirements as published by the Wyoming Attorney General's office, or as directed by the senior assistant attorney general assigned to WYDOT.

All agreements shall be forwarded to the WYDOT grant administrator for approval before execution.

Agreements subsidized with federal funds will be made available to the appropriate federal agency upon request. The Federal Highway Administration (FHWA) and the Federal Aviation Administration (FAA) have currently delegated their approval authority to WYDOT.

Agreements shall be executed by the consultant and the *City of Casper*.

SECTION XI. AUTHORIZATION TO PROCEED

Once the consultant agreement is finalized and executed, the *City of Casper* will notify the consultant using a written "Authorization to Proceed" to commence work.

Consultant services cannot proceed before the "Authorization to Proceed" is issued.

SECTION XII. AGREEMENT MODIFICATIONS

The *City of Casper* or the consultant may, during performance of the agreement, propose agreement modifications within the type of services under which the original agreement was procured. Changes in the scope, complexity or quantity of the work, or if changes causing an increase or decrease in agreement fees or time for performance are required, an equitable adjustment in fees and/or contract time will be negotiated with the consultant. Any additional services outside of the original agreement type of work will be procured under a new procurement process.

If changes are required in the agreement, a written request shall be made by the consultant to the *City of Casper* and negotiated between the consultant and the *City of Casper*. The agreement will

then be amended using documentation issued by the *City of Casper*. Agreement modifications must define and document the changes made to the agreement, establish any adjustment in agreement fees and payment, establish any adjustment in completion date, and be in compliance with terms and conditions of the original agreement. An adjustment in agreement fees and payments will be negotiated, as outlined in SECTION VIII – NEGOTIATING THE FINAL AGREEMENT AND COST PROPOSAL, including the fixed fee, if warranted.

If the consultant is unable to complete the work within the number of calendar days or the calendar date required by the agreement, the *City of Casper* may authorize a schedule modification after receiving the consultant’s written request showing sufficient justification for an extension in time to complete agreement required services. In some cases, the *City of Casper* may initiate the schedule modification, especially when the *City of Casper* has delayed progress. If the schedule modification is significant, the agreement will then be amended to specify an additional number of days or revised calendar date, and the *City of Casper* will document the approval action with a formal change order. Minor changes in schedule, without adjustment in agreement cost, can be accepted by the *City of Casper* with informal documentation.

All agreement modifications shall be forwarded to the WYDOT grant administrator for approval before execution.

Consultant work shall not begin on any change in services until the agreement modification describing those services and fee has been executed. Services performed without prior request and authorization are deemed to be covered in the compensation and time provided in the original agreement and previously executed change orders.

For those agreements processed consistent with SECTION IV(A) – Small Agreement – Estimated Cost at or less than the SAT, in no case will subsequent change orders be permitted to cause the total fee to exceed the SAT if federal funds are involved. Exceeding the SAT limitation may jeopardize federal participation in the change order or the entire agreement amount. If federal funds are not involved, the *City of Casper* should contact the WYDOT grant administrator, and they will review the circumstances and make a determination regarding escalation of the agreement above the SAT.

SECTION XIII. AGREEMENT ADMINISTRATION

The agreement for consultant services will identify the representative for the *City of Casper* as the primary contact through which the consultant will coordinate all phases of agreement work, terms and conditions. The *City of Casper* representative will:

1. Monitor the consultant’s work and acceptability of work, in compliance with the agreement.

2. Monitor the consultant's work progress – work performed versus agreement completion date – in compliance with the agreement.
3. Ensure the consultant's labor hours and fees are in accordance with the agreement and the percent of the contract total being invoiced is commensurate with the progress of the work.
4. Address consultant correspondence and resolve administrative issues.
5. Monitor the consultant and subconsultant(s) for compliance with ATTACHMENT 1 – FEDERAL GENERAL PROVISIONS, if required by the Agreement.
6. Administer breach of agreement, when required, consistent with procedures presented in ATTACHMENT 2 – BREACH OF AGREEMENT. Consult with the WYDOT grant administrator before initiating procedures leading to breach of agreement.
7. Close-out agreement when all work deliverables have been accepted and all consultant billings have been accepted.

The *City of Casper* will maintain a correspondence file for each consultant services agreement, documenting all aspects of the selection, negotiation, and administration processes. The *City of Casper* will retain such records for at least three (3) years following agreement completion or termination.

SECTION XIV. FINAL PERFORMANCE EVALUATION

When the consultant services specified in the agreement are completed and accepted, the *City of Casper* will evaluate the consultant's performance. This evaluation should consider such factors as the consultant's performance on specific elements of work, promptness in meeting schedules and deadlines, cooperation with the *City of Casper*, and overall performance in delivery of the agreement terms and conditions. Documentation will be prepared and provided to the consultant, and request consultant comments on the evaluation. Subsequently, a copy of the final evaluation documentation will be provided to the WYDOT grant administrator.

SECTION XV. ADMINISTRATION, COST PRINCIPLES, AUDIT REQUIREMENTS

The administrative policies and procedures of the *City of Casper* for the consultant selection process are presented throughout this document. The *City of Casper* is responsible for the oversight and administration of these policies and procedures. The WYDOT Internal Review Services program is responsible for the audit requirements.

References:

- 2 CFR 200, Uniform Administrative Requirements, Cost Principles, and Audit Requirements for Federal Awards.
- 23 CFR 172, Procurement, Management, and Administration of Engineering and Design Related Services.
- 23 USC 112(b)(2), Contracting for Engineering and Design Services.
- 40 USC 11, Sections 1101-1104, Selection of Architects and Engineers.
- 48 CFR 2.101, Federal Acquisition Regulations System, Definitions of Words and Terms, Definitions.

ATTACHMENT 1

FEDERAL GENERAL PROVISIONS

The below General Provisions shall also apply to all subconsultants engaged by the Consultant.

SECTION A. ASSUMPTION OF RISK

The Consultant shall assume the risk of any loss of state or federal funding, either administrative or program dollars, due to its failure to comply with state or federal requirements. The *City of Casper* will notify the Consultant of any state or federal determination of noncompliance.

SECTION B. AUDITING AND ACCOUNTING

The Consultant shall make available to the *City of Casper* their accounting records for progress and post-performance audits when deemed necessary by the *City of Casper*.

SECTION C. BREACH OF AGREEMENT

The Consultant agrees to provide all professional services as required by the terms, conditions, provisions, and obligations of this Agreement. Failure by the Consultant to perform as required by the terms, conditions, provisions, or obligations of this Agreement shall constitute a breach of agreement. The *City of Casper* will consider a Consultant's failure to perform as a material breach of agreement when it can be determined that the terms, conditions, provisions, or obligations of the Agreement cannot be completed and the *City of Casper* will incur additional cost, lost opportunity, or additional time to obtain the same or equal Agreement deliverables. A material breach may result in remedies as the *City of Casper* deems appropriate, which may include, but are not limited to:

1. Termination as provided in SECTION T – TERMINATION OF AGREEMENT;
2. Withholding monthly progress payments;
3. Assessing damages/sanctions;
4. Disqualifying the Consultant from future solicitations; and/or
5. Legal remedy.

SECTION D. CERTIFICATION FOR LIMITATIONS ON LOBBYING ACTIVITIES

This provision is applicable to all Agreements exceeding One Hundred Thousand dollars (\$100,000). By signing this Agreement, the Consultant certifies and agrees that, to the best of their knowledge:

1. No federal appropriated funds have been paid or will be paid, by or on behalf of

the Consultant, to any person for influencing or attempting to influence an officer or employee of an agency, a Member of Congress, an officer or employee of Congress, or an employee of a Member of Congress in connection with the awarding of any federal contract, the making of any federal grant, the making of any federal loan, the entering into of any cooperative agreement, and the extension, continuation, renewal, amendment, or modification of any federal contract, grant, loan, or cooperative agreement.

2. If any funds other than federal appropriated funds have been paid or will be paid to any person for influencing or attempting to influence an officer or employee of any agency, a Member of Congress, an officer or employee of Congress, or an employee of a Member of Congress in connection with this federal contract, grant, loan, or cooperative agreement, the Consultant shall complete and submit Standard Form-LLL, "Disclosure Form to Report Lobbying," in accordance with its instructions.

This certification is a material representation of fact upon which reliance was placed when this Agreement was made or entered into. Failure by the Consultant to carry out these requirements may be a material breach of this Agreement, which may result in remedies as provided in SECTION C – BREACH OF AGREEMENT.

SECTION E. COMPLIANCE WITH LAWS

The Consultant shall keep informed of and comply with all applicable federal, state, and local laws and regulations in the performance of this Agreement.

SECTION F. CONFLICTS OF INTEREST

The Consultant shall not engage in providing consultation or representation of clients, agencies, or firms which may constitute a conflict of interest which results in a disadvantage to the *City of Casper*, or a disclosure which would adversely affect the interests of the *City of Casper*. This does not prohibit or affect the Consultant's ability to engage in consultations, evaluations or representation under agreement with other agencies, firms, facilities, or attorneys so long as no conflict exists.

A conflict of interest may be considered a material breach of this Agreement. A material breach under this section may result in remedies as provided in SECTION C – BREACH OF AGREEMENT. In the event the Agreement is terminated under this provision, the Consultant shall take steps to insure that the file, evidence, evaluation and data are provided to the *City of Casper* or its designee.

The Consultant shall disclose, in writing, any potential or actual conflict of interest to the *City of Casper*, including financial or other personal interests.

SECTION G. DETERMINATION OF ALLOWABLE COSTS

The Consultant shall assure, prior to submittal of periodic progress payments, that all costs are in accordance with federal cost principals as provided in 48 CFR 31. Failure by the Consultant to carry out these requirements may be a material breach of this Agreement, which may result in remedies as provided in SECTION C – BREACH OF AGREEMENT.

SECTION H. DISADVANTAGED BUSINESS ENTERPRISE ASSURANCE

The Consultant or subconsultant shall not discriminate on the basis of race, color, national origin, or sex in the performance of this Agreement. The Consultant shall carry out applicable requirements of 49 CFR 26 in all subconsultant contract documents.

Failure by the Consultant to carry out these requirements may be a material breach of this Agreement, which may result in remedies as provided in SECTION C – BREACH OF AGREEMENT.

SECTION I. ENVIRONMENTAL POLICY ACTS

The Consultant agrees all activities under this Agreement shall comply with the Clean Air Act, the Clean Water Act, the National Environmental Policy Act, and other related provisions of federal environmental protection laws, rules or regulations.

SECTION J. ERRORS AND OMISSIONS

The Consultant shall be responsible for assuring that professional services provided under this Agreement are accurate and without mistakes or omissions. The Consultant shall endeavor to perform services in a manner consistent with that degree of care and skill ordinarily exercised by members of the same profession currently practicing under similar circumstances (Standard/Duty of Care). The *City of Casper* will notify the Consultant at the earliest possible time of the professional services which require corrective action and the Consultant, by mutual agreement with the *City of Casper* and without additional compensation, shall correct those services. Failure by the Consultant to carry out these requirements may be a material breach of this Agreement, which may result in remedies as provided in SECTION C – BREACH OF AGREEMENT.

SECTION K. HUMAN TRAFFICKING

As required by 22 USC 7104(g), 2 CFR 175, and 48 CFR 52.222-50 (Amended March 2015), severe forms of human trafficking, procurement of commercial sex acts, and the use of forced

labor are prohibited. The March 2015 amendments expand the original requirements and introduce a list of specific types of conduct that are prohibited. The amendments modify mandatory disclosure obligations and specify the minimum level of cooperation required of consultants responding to a trafficking investigation. Failure by the Consultant to carry out these requirements may be a material breach of this Agreement, which may result in remedies as provided in SECTION C – BREACH OF AGREEMENT.

SECTION L. KICKBACKS

The Consultant certifies and warrants that no gratuities, kickbacks, or contingency fees were paid in connection with this Agreement, nor were any fees, commissions, gifts, or other considerations made contingent upon the award of this Agreement. If the Consultant breaches or violates this warranty, the *City of Casper* may, at its discretion, terminate this Agreement without liability to the *City of Casper*, or deduct from the agreed upon price or consideration, or otherwise recover, the full amount of any commission, percentage, brokerage, or contingency fee.

SECTION M. MANDATORY DISCLOSURES

The Consultant shall disclose, in a timely manner, in writing, to the *City of Casper* all violations of federal criminal law involving fraud, bribery, or gratuity violations potentially affecting this award. Failure to make required disclosures can result in remedies for non-compliance including suspension or debarment.

SECTION N. MONITORING ACTIVITIES

The *City of Casper* shall have the right to monitor all activities related to this Agreement that are performed by the Consultant or its subconsultants. This shall include, but not be limited to, the right to make site inspections at any time and with reasonable notice; to bring experts and consultants on site to examine or evaluate completed work or work in progress; to examine the books, ledgers, documents, papers, and records pertinent to this Agreement; and to observe personnel in every phase of performance of the related work.

SECTION O. OWNERSHIP OF DOCUMENTS/WORK PRODUCT

All documents, reports, records, field notes, materials and data of any kind resulting from performance of this Agreement are at all times the property of the *City of Casper*. Said documents and/or work products shall be delivered to the *City of Casper* upon suspension, termination or completion of the services by the Consultant.

SECTION P. PATENT OR COPYRIGHT PROTECTION, AND RIGHTS IN DATA

The Consultant recognizes that certain proprietary matters or techniques may be subject to patent, trademark, copyright, license, or other similar restrictions, and warrants that no work performed by the Consultant or its subconsultants shall violate any such restriction. The Consultant shall defend and indemnify the *City of Casper* for any violation or alleged violation of such patent, trademark, copyright, license, or other restrictions.

Copyrighting or other exclusions placed on any documents or materials developed by the Consultant, its sublets, agents or assigns under this Agreement are prohibited.

Data produced, furnished, acquired, or used in meeting the terms and conditions of this Agreement are available to the *City of Casper*, WYDOT and/or the federal funding agency with unlimited rights. Data means all recorded information, regardless of form, to include both technical – scientific or technical nature - and computer software information. It does not include information related to administration of the Agreement such as financial, cost or pricing, or management information. Unlimited rights means that the *City of Casper*, State or federal agency has the right to use, disclose, reproduce, and distribute the data in any manner and for any purpose, and to permit others to also have unlimited rights. Meanings and uses described in this General Provision are superseded and/or supplemented by 48 CFR 52.227-14.

SECTION Q. PROFESSIONAL REGISTRATION

The Consultant shall endorse, if required by law, plans and reports prepared under this Agreement, and shall affix thereto his or her seal of professional registration, showing that he or she is licensed to practice in the State of Wyoming.

SECTION R. PUBLICITY

Any publicity given to the program or services provided herein, including, but not limited to, notices, information, pamphlets, press releases, research, reports, signs, and similar public notices prepared by or for the Consultant and related to the services and work to be performed under this Agreement, shall identify the *City of Casper*, WYDOT and the federal funding agency as the sponsoring agencies and shall not be released without prior written approval of the *City of Casper*.

SECTION S. SUSPENSION AND DEBARMENT

By signing this Agreement, the Consultant certifies that neither it nor its principals are presently debarred, suspended, proposed for debarment, declared ineligible, or voluntarily excluded from participation in this transaction nor from federal financial or non-financial assistance, nor are any of the participants involved in the execution of this Agreement suspended, debarred, or

voluntarily excluded by any federal department or agency in accordance with the Office of Management and Budget guidelines at 2 CFR 180 and supplemented by 2 CFR 1200, or are on the disbarred vendors list at www.sam.gov/portal/public/SAM/. Further, the Consultant agrees to notify the *City of Casper* by certified mail should it or any of its agents become debarred, suspended, or voluntarily excluded during the term of this Agreement. Failure by the Consultant to carry out these requirements may be a material breach of this Agreement, which may result in remedies as provided in SECTION C – BREACH OF AGREEMENT.

SECTION T. TERMINATION OF AGREEMENT

The *City of Casper* may at any time, by written notice, terminate all or part of the Agreement when the *City of Casper* determines that the Consultant has failed to perform as required by the terms, conditions, provisions, or obligations of the Agreement – Termination for Cause or Breach – or the *City of Casper* determines that termination is in the public’s best interest – Termination on Public’s Behalf/Convenience. In this event, compensation will be made to the Consultant based upon the progress of the work performed prior to termination. Work performed shall be defined as the deliverables specified in the Agreement and accepted by the *City of Casper*, and not the labor hours billed. The *City of Casper* will notify the Consultant, in writing, of Agreement termination.

SECTION U. TITLE VI ASSURANCES FOR NON-DISCRIMINATION

The Consultant agrees to comply with the requirements of the nondiscrimination clauses as described in the U.S. Department of Transportation (DOT) Order 1050.2.

(In addition to the Federal General Provisions listed above, additional provisions available from WYDOT shall be used in all consultant contracts which utilize Federal Transit Administration funding.)

ATTACHMENT 2

BREACH OF AGREEMENT (Administrative Written Procedures)

Consultant agreements will incorporate Federal General Provisions regarding breach of agreement consistent with 23 CFR 172 and 2 CFR 200. These Regulations require written procedures to address contractual, legal, and administrative remedies including sanctions and penalties where consultants breach agreement terms, conditions, provisions, or obligations. For purposes of these written procedures, the Agreement terms, conditions, provisions, or obligations will be referred to as Agreement Services.

Numerous Federal General Provisions will be administered using these written procedures. For purposes of administering consultant agreements, breach of agreement may result when analyzing a consultant's professional services under any of the following Federal General Provisions:

ATTACHMENT 1, FEDERAL GENERAL PROVISIONS

- SECTION C. BREACH OF AGREEMENT
- SECTION D. CERTIFICATION FOR LIMITATIONS ON LOBBYING ACTIVITIES
- SECTION F. CONFLICTS OF INTEREST
- SECTION G. DETERMINATION OF ALLOWABLE COSTS
- SECTION H. DISADVANTAGED BUSINESS ENTERPRISE ASSURANCE
- SECTION J. ERRORS AND OMISSIONS
- SECTION K. HUMAN TRAFFICKING
- SECTION S. SUSPENSION AND DEBARMENT

The consultant's responsibility to make prompt payment to subconsultants will be administered through these written procedures, as required by SECTION VI(C) – Consultant Payments and Retainage and the consultant agreement.

Contractual Remedy

Contractual remedy is provided when the above provisions are physically incorporated, or incorporated by reference, into an executed Agreement. Additionally, contractual remedy requires the physical incorporation of ATTACHMENT 1, FEDERAL GENERAL PROVISIONS, SECTION T – TERMINATION OF AGREEMENT.

Legal Remedy

Legal remedy is provided by the physical incorporation of ATTACHMENT 1, FEDERAL GENERAL PROVISIONS, SECTION E – COMPLIANCE WITH LAWS and enforcement of the Agreement as governed by the laws of the State of Wyoming.

Administrative Procedures, Sanctions, and Penalties

City of Casper concerns with consultant performance and/or adherence to Agreement Services will most often be resolved through the coordination and resolution efforts as outline in SECTION XIII – AGREEMENT ADMINISTRATION of this document. The authorized representative/ primary contact of the *City of Casper* should document all administrative issues and subsequent resolutions, from start to completion of the Agreement.

There may be an occurrence when a cooperative and acceptable resolution cannot be reached between the *City of Casper* and the Consultant. At those occurrences, the *City of Casper* will typically make the determination that the Consultant has failed to perform Agreement-required acceptable work, has failed to progress in the performance of Agreement Services, or has not and will not comply with General Provisions. When that determination concludes that the Agreement Services cannot be completed and the *City of Casper* will incur additional cost, lost opportunity, or additional time to obtain the same or equal Agreement deliverables, the threshold for a material breach of agreement has been reached and will invoke ATTACHMENT 1, FEDERAL GENERAL PROVISIONS, SECTION C – BREACH OF AGREEMENT and the resultant remedies, including ATTACHMENT 1, FEDERAL GENERAL PROVISIONS, SECTION T – TERMINATION OF AGREEMENT.

A *City of Casper* determination that the Consultant has failed to perform Agreement-required acceptable work, has failed to progress in the performance of Agreement Services, or has not and will not comply with General Provisions will need to be supported by the *City of Casper* documentation of monitoring activities as allowed by ATTACHMENT 1, FEDERAL GENERAL PROVISIONS, SECTION N – MONITORING ACTIVITIES. Issues concerning the Consultant's billing of allowable costs should be evaluated in accordance with ATTACHMENT 1, FEDERAL GENERAL PROVISIONS, SECTION B – AUDITING AND ACCOUNTING.

The threshold for a material breach of agreement requires that the Consultant has failed to perform Agreement Services and that the *City of Casper* has or will incur additional cost, lost opportunity, or additional time to obtain the same or equal Agreement deliverables. Both represent a high threshold to assure an acceptable outcome and, as a result, the *City of Casper* representative through monitoring activities must identify and document unresolved issues early in the Agreement, before either the Consultant or the *City of Casper* has incurred substantial cost or time. All unresolved issues should be promptly addressed, either reaching resolution, arriving at reasonable penalties/sanctions, or concluding breach of agreement with the resultant remedies,

including ATTACHMENT 1, FEDERAL GENERAL PROVISIONS, SECTION T – TERMINATION OF AGREEMENT.

Penalties and/or sanctions typically available to the *City of Casper* would be structured as 1) compensatory damages, 2) specific performance, or 3) termination.

Damages, based on additional cost or time incurred by the *City of Casper*, could be quantified and pursued. Damages, based on lost opportunity incurred by the *City of Casper*, may be more difficult to quantify. Lost opportunity could include *City of Casper* delays in the delivery of supplemental work or successor agreements for work, or delay in the year of project construction and the related increased construction costs. Other lost opportunities may be identified and quantified.

Specific performance would require the Consultant to pursue Agreement Services, with adjustment to allowable costs. Specific performance would be used as a remedy, either prior to or for breach of agreement, if the work required by the Agreement required special expertise, is an emergency, or is only available from a single or restricted number of firms. In those cases, damages would not suffice to place the *City of Casper* in as good a position as it would have been had the breach not occurred.

Termination of the Agreement is presented in ATTACHMENT 1, FEDERAL GENERAL PROVISIONS, SECTION T – TERMINATION OF AGREEMENT. The *City of Casper* may terminate the Agreement, and either pursue restitution or not pursue restitution. Restitution, as a remedy, means that the *City of Casper* is put back in the position it was in prior to the breach; without restitution, the Agreement is terminated with both the Consultant and the *City of Casper* no longer under any Agreement obligation.

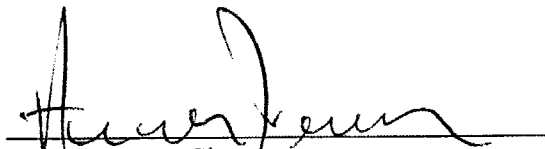
Signature

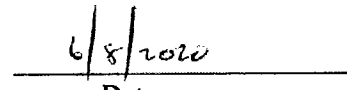
Date



TAP Attachment L: Title VI
[INSERT TITLE VI FORM]
City of Casper

IDENTIFICATION OF TITLE VI / EEO COORDINATOR

Funding Recipient/Contractor Name:	City of Casper
WYDOT Project #:	
Project Location:	Casper, Wyoming
Phone #:	(307) 235-8341

TITLE VI/EEO IDENTIFICATION REQUIREMENTS

Has the Title VI/EEO Coordinator attended the Local Public Agency training from the Wyoming Department of Transportation? <i>(Project Sponsor Only – Contractors need not respond)</i>	YES <input type="checkbox"/>	NO <input checked="" type="checkbox"/>
Has the Coordinator changed since the last submitted Identification form?	YES <input checked="" type="checkbox"/>	NO <input type="checkbox"/>
Is the Coordinator clearly identified within the organization as the individual who will process and/or notify required staff of Title VI/EEO identified issues?	YES <input checked="" type="checkbox"/>	NO <input type="checkbox"/>

TITLE VI/EEO COORDINATOR IDENTIFICATION

As required in the Equal Employment Opportunity Special Provisions included in federally funded highway construction contracts/agreements, this form acts as official identification of the Title VI/EEO Coordinator (and/or update) to the Wyoming Department of Transportation and the U.S. Federal Highway Administration (FHWA).

The aforementioned Funding Recipient/Contractor understands that additional information regarding the Coordinator, the Title VI/EEO policy and other aspects of the construction contract compliance program may be requested and/or reviewed at the request of the funding agency.

Title VI/EEO Coordinator: Nicole Carlson	Signature: 	Date: 6-2-2020
Title VI/EEO Coordinator Work Title: Human Resources Supervisor	Email Address: ncarlson@casperwy.gov	Phone #: (307) 235-8274

APPOINTING OFFICIAL'S ACKNOWLEDGEMENT

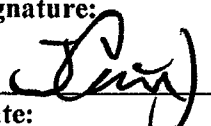
Appointing Official's Name: J. Carter Napier	Signature: 
Appointing Official's Work Title: City Manager	Date: 6/4/20

For questions regarding this form, contact WYDOT's Office of Civil Rights Program Manager, Lisa Fresquez at 307.777.4457 or lisa.fresquez@wyo.gov.

The United States Department of Transportation

Standard Title VI Assurances/Non-Discrimination Provisions

DOT Order No. 1050.2A

City of Casper

City of Casper (herein referred to as the "Recipient"), HEREBY AGREES THAT, as a condition to receiving any Federal financial assistance from the United States Department of Transportation (DOT), through the Federal Highway Administration (FHWA), is subject to and will comply with the following:

Statutory/Regulatory Authorities

- Title VI of the Civil Rights Act of 1964 (42 U.S.C. § 2000d *et seq.*, 78 stat. 252), (prohibits discrimination on the basis of race, color, national origin);
- 49 C.F.R. Part 21 (entitled *Nondiscrimination In Federally-Assisted Programs Of The Department Of Transportation—Effectuation Of Title VI Of The Civil Rights Act Of 1964*);
- 28 C.F.R. section 50.3 (U.S. Department of Justice Guidelines for Enforcement of Title VI of the Civil Rights Act of 1964);

Modal Operating Administration may include additional Statutory/Regulatory Authorities here.

The preceding statutory and regulatory cites hereinafter are referred to as the "Acts" and "Regulations," respectively.

General Assurances

In accordance with the Acts, the Regulations, and other pertinent directives, circulars, policy, memoranda, and/or guidance, the Recipient hereby gives assurance that it will promptly take any measures necessary to ensure that:

"No person in the United States shall, on the grounds of race, color, or national origin, be excluded from participation in, be denied the benefits of, or be otherwise subjected to discrimination under any program or activity for which the Recipient receives Federal financial assistance from DOT, including the FHWA."

The Civil Rights Restoration Act of 1987 clarified the original intent of Congress, with respect to Title VI and other Non-discrimination requirements (The Age Discrimination Act of 1975, and Section 504 of the Rehabilitation Act of 1973) by restoring the broad, institutional-wide scope and coverage of these non-discrimination statutes and requirements to include all programs and activities of the Recipient, so long as any portion of the program is Federally-assisted.

Modal Operating Administration may include additional General Assurances in this section, or reference an addendum here.

Specific Assurances

More specifically, and without limiting the above general Assurances, the Recipient agrees with and gives the following Assurances with respect to its Federally assisted FHWA Program:

1. The Recipient agrees that each "activity," "facility," or "program," as defined in §§ 21.23 (b) and 21.23 (e) of 49 C.F.R. § 21 will be (with regard to an "activity") facilitated, or will be (with regard to a "facility") operated, or will be (with regard to a "program") conducted in compliance with all requirements imposed by, or pursuant to the Acts and the Regulations;
2. The Recipient will insert the following notification in all solicitations for bids, Requests For Proposals for work, or material subject to the Acts and the Regulations made in connection with all Federal Highway Programs and, in adapted form, in all proposals for negotiated agreements regardless of funding source:

City of Casper, in accordance with the provisions of Title VI of the Civil Rights Act of 1964 (78 Stat. 252, 42 U.S.C. §§ 2000d to 2000d-4) and the Regulations, hereby notifies all bidders that it will affirmatively ensure that any contract entered into pursuant to this advertisement, disadvantaged business enterprises will be afforded full opportunity to submit bids in response to this invitation and will not be discriminated against on the grounds of race, color, or national origin in consideration for an award.”;

3. The Recipient will insert the clauses of Appendix A and E of this Assurance in every contract or agreement subject to the Acts and the Regulations;
4. The Recipient will insert the clauses of Appendix B of this Assurance, as a covenant running with the land, in any deed from the United States effecting or recording a transfer of real property, structures, use, or improvements thereon or interest therein to a Recipient;
5. That where the Recipient receives Federal financial assistance to construct a facility, or part of a facility, the Assurance will extend to the entire facility and facilities operated in connection therewith;
6. That where the Recipient receives Federal financial assistance in the form, or for the acquisition of real property or an interest in real property, the Assurance will extend to rights to space on, over, or under such property;
7. That the Recipient will include the clauses set forth in Appendix C and Appendix D of this Assurance, as a covenant running with the land, in any future deeds, leases, licenses, permits, or similar instruments entered into by the Recipient with other parties:
 - a. for the subsequent transfer of real property acquired or improved under the applicable activity, project, or program; and
 - b. for the construction or use of, or access to, space on, over, or under real property acquired or improved under the applicable activity, project, or program.
8. That this Assurance obligates the Recipient for the period during which Federal financial assistance is extended to the program, except where the Federal financial assistance is to provide, or is in the form of, personal property, or real property, or interest therein, or structures or improvements thereon, in which case the Assurance obligates the Recipient, or any transferee for the longer of the following periods:
 - a. the period during which the property is used for a purpose for which the Federal financial assistance is extended, or for another purpose involving the provision of similar services or benefits; or
 - b. the period during which the Recipient retains ownership or possession of the property.

9. The Recipient will provide for such methods of administration for the program as are found by the Secretary of Transportation or the official to whom he/she delegates specific authority to give reasonable guarantee that it, other recipients, sub-recipients, sub-grantees, contractors, subcontractors, consultants, transferees, successors in interest, and other participants of Federal financial assistance under such program will comply with all requirements imposed or pursuant to the Acts, the Regulations, and this Assurance.
10. The Recipient agrees that the United States has a right to seek judicial enforcement with regard to any matter arising under the Acts, the Regulations, and this Assurance.

Modal Operating Administration may include additional Specific Assurances in this section.

By signing this ASSURANCE, City of Casper also agrees to comply (and require any sub-recipients, sub-grantees, contractors, successors, transferees, and/or assignees to comply) with all applicable provisions governing the FHWA access to records, accounts, documents, information, facilities, and staff. You also recognize that you must comply with any program or compliance reviews, and/or complaint investigations conducted by the FHWA. You must keep records, reports, and submit the material for review upon request to FHWA, or its designee in a timely, complete, and accurate way. Additionally, you must comply with all other reporting, data collection, and evaluation requirements, as prescribed by law or detailed in program guidance.

City of Casper gives this ASSURANCE in consideration of and for obtaining any Federal grants, loans, contracts, agreements, property, and/or discounts, or other Federal-aid and Federal financial assistance extended after the date hereof to the recipients by the Department of Transportation under the FHWA Program. This ASSURANCE is binding on [insert State], other recipients, sub-recipients, sub-grantees, contractors, subcontractors and their subcontractors', transferees, successors in interest, and any other participants in the FHWA Program. The person (s) signing below is authorized to sign this ASSURANCE on behalf of the Recipient.

City of Casper

By: _____

(Signature of Authorized Official)

DATE: _____

APPENDIX A

During the performance of this contract, the contractor, for itself, its assignees, and successors in interest (hereinafter referred to as the "contractor") agrees as follows:

1. **Compliance with Regulations:** The contractor (hereinafter includes consultants) will comply with the Acts and the Regulations relative to Nondiscrimination in Federally-assisted programs of the U.S. Department of Transportation, **Federal Highway Administration (FHWA)**, as they may be amended from time to time, which are herein incorporated by reference and made a part of this contract.
2. **Nondiscrimination:** The contractor, with regard to the work performed by it during the contract, will not discriminate on the grounds of race, color, or national origin in the selection and retention of subcontractors, including procurements of materials and leases of equipment. The contractor will not participate directly or indirectly in the discrimination prohibited by the Acts and the Regulations as set forth in Appendix E, including employment practices when the contract covers any activity, project, or program set forth in Appendix B of 49 CFR Part 21.
3. **Solicitations for Subcontracts, Including Procurements of Materials and Equipment:** In all solicitations, either by competitive bidding, or negotiation made by the contractor for work to be performed under a subcontract, including procurements of materials, or leases of equipment, each potential subcontractor or supplier will be notified by the contractor of the contractor's obligations under this contract and the Acts and the Regulations relative to Non-discrimination on the grounds of race, color, or national origin.
4. **Information and Reports:** The contractor will provide all information and reports required by the Acts, the Regulations and directives issued pursuant thereto and will permit access to its books, records, accounts, other sources of information, and its facilities as may be determined by the Recipient or the FHWA to be pertinent to ascertain compliance with such Acts, Regulations, and instructions. Where any information required of a contractor is in the exclusive possession of another who fails or refuses to furnish the information, the contractor will so certify to the Recipient or the FHWA, as appropriate, and will set forth what efforts it has made to obtain the information.
5. **Sanctions for Noncompliance:** In the event of a contractor's noncompliance with the Non-discrimination provisions of this contract, the Recipient will impose such contract sanctions as it or the FHWA may determine to be appropriate, including, but not limited to:
 - a. withholding payments to the contractor under the contract until the contractor complies; and/or
 - b. cancelling, terminating, or suspending a contract, in whole or in part.
6. **Incorporation of Provisions:** The contractor will include the provisions of paragraphs one through six in every subcontract, including procurements of materials and leases of equipment, unless exempt by the Acts, the Regulations and directives issued pursuant thereto. The contractor will take action with respect to any subcontract or procurement as the Recipient or the FHWA may direct as a means of enforcing such provisions including sanctions for noncompliance. Provided, that if the contractor becomes involved in, or is threatened with litigation by a subcontractor, or supplier because of such direction, the contractor may request the Recipient to enter into any litigation to protect the interests of the Recipient. In addition, the contractor may request the United States to enter into the litigation to protect the interests of the United States.

CLAUSES FOR DEEDS TRANSFERRING UNITED STATES PROPERTY

APPENDIX B

The following clauses will be included in deeds effecting or recording the transfer of real property, structures, or improvements thereon, or granting interest therein from the United States pursuant to the provisions of Assurance 4:

NOW, THEREFORE, the Department of Transportation as authorized by law and upon the condition that City of Casper will accept title to the lands and maintain the project constructed thereon in accordance with Moving Ahead for Progress in the 21st Century (MAP-21), the Regulations for the Administration of Federal Highway Administration (FHWA) Program, and the policies and procedures prescribed by the FHWA of the Department of Transportation in accordance and in compliance with all requirements imposed by Title 49, Code of Federal Regulations, Department of Transportation, Subtitle A, Office of the Secretary, Part 21, Non-discrimination in Federally-assisted programs of the Department of Transportation pertaining to and effectuating the provisions of Title VI of the Civil Rights Act of 1964 (78 Stat. 252; 42 U.S.C. § 2000d to 2000d-4), does hereby remise, release, quitclaim and convey unto City of Casper all the right, title and interest of the Department of Transportation in and to said lands described in Exhibit "A" (if applicable) attached hereto and made a part hereof.

(HABENDUM CLAUSE)

TO HAVE AND TO HOLD said lands and interests therein unto City of Casper and its successors forever, subject, however, to the covenants, conditions, restrictions and reservations herein contained as follows, which will remain in effect for the period during which the real property or structures are used for a purpose for which Federal financial assistance is extended or for another purpose involving the provision of similar services or benefits and will be binding on City of Casper, its successors and assigns.

City of Casper, in consideration of the conveyance of said lands and interests in lands, does hereby covenant and agree as a covenant running with the land for itself, its successors and assigns, that (1) no person will on the grounds of race, color, or national origin be excluded from participation in, be denied the benefits of, or be otherwise subjected to discrimination with regard to any facility located wholly or in part on, over, or under such lands hereby conveyed [,] [and]* (2) that City of Casper will use the lands and interests in lands and interests in lands so conveyed, in compliance with all requirements imposed by or pursuant to Title 49, Code of Federal Regulations, Department of Transportation, Subtitle A, Office of the Secretary, Part 21, Non-discrimination in Federally-assisted programs of the Department of Transportation, Effectuation of Title VI of the Civil Rights Act of 1964, and as said Regulations and Acts may be amended, and (3) that in the event of breach of any of the above-mentioned non-discrimination conditions, the Department will have a right to enter or re-enter said lands and facilities on said land, and that above described land and facilities will there on revert to and vest in

and become the absolute property of the Department of Transportation and its assigns as such interest existed prior to this instruction.*

(*Reverter clause and related language to be used only when it is determined that such a clause is necessary in order to effectuate the purpose of Title VI.)

**CLAUSES FOR TRANSFER OF REAL PROPERTY ACQUIRED OR IMPROVED UNDER
THE ACTIVITY, FACILITY OR PROGRAM**

APPENDIX C

The following clauses will be included in deeds, licenses, leases, permits, or similar instruments entered into by City of Casper pursuant to the provisions of Assurance 7(a):

- A. The (grantee, lessee, permittee, etc. as appropriate) for himself/herself, his/her heirs, personal representatives, successors in interest, and assigns, as a part of the consideration hereof, does hereby covenant and agree [in the case of deeds and leases add "as a covenant running with the land"] that:
1. In the event facilities are constructed, maintained, or otherwise operated on the property described in this (deed, license, lease, permit, etc.) for a purpose for which a Department of Transportation activity, facility, or program is extended or for another purpose involving the provision of similar services or benefits, the (grantee, licensee, lessee, permittee, etc.) will maintain and operate such facilities and services in compliance with all requirements imposed by the Acts and Regulations (as may be amended) such that no person on the grounds of race, color, or national origin will be excluded from participation in, denied the benefits of, or be otherwise subjected to discrimination in the use of said facilities.
- B. With respect to licenses, leases, permits, etc., in the event of breach of any of the above Non-discrimination covenants, City of Casper will have the right to terminate the (lease, license, permit, etc.) and to enter, re-enter, and repossess said lands and facilities thereon, and hold the same as if the (lease, license, permit, etc.) had never been made or issued.*
- C. With respect to a deed, in the event of breach of any of the above Non-discrimination covenants, the City of Casper will have the right to enter or re-enter the lands and facilities thereon, and the above described lands and facilities will there upon revert to and vest in and become the absolute property of the City of Casper and its assigns.*

(*Reverter clause and related language to be used only when it is determined that such a clause is necessary to effectuate the purpose of Title VI.)

**CLAUSES FOR CONSTRUCTION/USE/ACCESS TO REAL PROPERTY ACQUIRED
UNDER THE ACTIVITY, FACILITY OR PROGRAM**

APPENDIX D

The following clauses will be included in deeds, licenses, permits, or similar instruments/agreements entered into by _____ City of Casper _____ pursuant to the provisions of Assurance 7(b):

- A. The (grantee, licensee, permittee, etc., as appropriate) for himself/herself, his/her heirs, personal representatives, successors in interest, and assigns, as a part of the consideration hereof, does hereby covenant and agree (in the case of deeds and leases add, "as a covenant running with the land") that (1) no person on the ground of race, color, or national origin will be excluded from participation in, denied the benefits of, or be otherwise subjected to discrimination in the use of said facilities, (2) that in the construction of any improvements on, over, or under such land, and the furnishing of services thereon, no person on the ground of race, color, or national origin will be excluded from participation in, denied the benefits of, or otherwise be subjected to discrimination, (3) that the (grantee, licensee, lessee, permittee, etc.) will use the premises in compliance with all other requirements imposed by or pursuant to the Acts and Regulations, as amended, set forth in this Assurance.
- B. With respect to (licenses, leases, permits, etc.), in the event of breach of any of the above Non-discrimination covenants, the _____ City of Casper _____ will have the right to terminate the (license, permit, etc., as appropriate) and to enter or re-enter and repossess said land and the facilities thereon, and hold the same as if said (license, permit, etc., as appropriate) had never been made or issued.*
- C. With respect to deeds, in the event of breach of any of the above Non-discrimination covenants, the _____ City of Casper _____ will there upon revert to and vest in and become the absolute property of _____ City of Casper _____ and its assigns.*

(*Reverter clause and related language to be used only when it is determined that such a clause is necessary to effectuate the purpose of Title VI.)

APPENDIX E

During the performance of this contract, the contractor, for itself, its assignees, and successors in interest (hereinafter referred to as the "contractor") agrees to comply with the following non-discrimination statutes and authorities; including but not limited to:

- Title VI of the Civil Rights Act of 1964 (42 U.S.C. § 2000d *et seq.*, 78 stat. 252), (prohibits discrimination on the basis of race, color, national origin); and 49 CFR Part 21;
- The Uniform Relocation Assistance and Real Property Acquisition Policies Act of 1970, (42 U.S.C. § 4601), (prohibits unfair treatment of persons displaced or whose property has been acquired because of Federal or Federal-aid programs and projects);
- Federal-Aid Highway Act of 1973, (23 U.S.C. § 324 *et seq.*), (prohibits discrimination on the basis of sex);
- Section 504 of the Rehabilitation Act of 1973, (29 U.S.C. § 794 *et seq.*), as amended, (prohibits discrimination on the basis of disability); and 49 CFR Part 27;
- The Age Discrimination Act of 1975, as amended, (42 U.S.C. § 6101 *et seq.*), (prohibits discrimination on the basis of age);
- Airport and Airway Improvement Act of 1982, (49 USC § 471, Section 47123), as amended, (prohibits discrimination based on race, creed, color, national origin, or sex);
- The Civil Rights Restoration Act of 1987, (PL 100-209), (Broadened the scope, coverage and applicability of Title VI of the Civil Rights Act of 1964, The Age Discrimination Act of 1975 and Section 504 of the Rehabilitation Act of 1973, by expanding the definition of the terms "programs or activities" to include all of the programs or activities of the Federal-aid recipients, sub-recipients and contractors, whether such programs or activities are Federally funded or not);
- Titles II and III of the Americans with Disabilities Act, which prohibit discrimination on the basis of disability in the operation of public entities, public and private transportation systems, places of public accommodation, and certain testing entities (42 U.S.C. §§ 12131 -- 12189) as implemented by Department of Transportation regulations at 49 C.F.R. parts 37 and 38;
- The Federal Aviation Administration's Non-discrimination statute (49 U.S.C. § 47123) (prohibits discrimination on the basis of race, color, national origin, and sex);
- Executive Order 12898, Federal Actions to Address Environmental Justice in Minority Populations and Low-Income Populations, which ensures non-discrimination against minority populations by discouraging programs, policies, and activities with disproportionately high and adverse human health or environmental effects on minority and low-income populations;
- Executive Order 13166, Improving Access to Services for Persons with Limited English Proficiency, and resulting agency guidance, national origin discrimination includes discrimination because of limited English proficiency (LEP). To ensure compliance with Title VI, you must take reasonable steps to ensure that LEP persons have meaningful access to your programs (70 Fed. Reg. at 74087 to 74100);
- Title IX of the Education Amendments of 1972, as amended, which prohibits you from discriminating because of sex in education programs or activities (20 U.S.C. 1681 *et seq.*).



TAP Attachment M: *sam.gov* Proof of Registration
[INSERT sam.gov Proof of Current Registration]
City of Casper



A NEW WAY TO SIGN IN - If you already have a SAM account, use your SAM email for login.gov.

Log In

Login.gov FAQs

ALERT: SAM.gov will be down for scheduled maintenance Saturday, 06/13/2020 from 8:00 AM to 1:00 PM

Entity Dashboard

CASPER, CITY OF
 DUNS: 152720140 CAGE Code: 4ART4
 Status: Active
 Expiration Date: 03/16/2021
 Purpose of Registration: Federal Assistance Awards Only

200 NORTH DAVID ST STE 107
 CASPER, WY, 82601-1815,
 UNITED STATES

- ▶ [Entity Overview](#)
- ▶ [Entity Registration](#)
 - ▶ [Core Data](#)
 - ▶ [Assertions](#)
 - ▶ [Reps & Certs](#)
 - ▶ [POCs](#)
- ▶ [Exclusions](#)
 - ▶ [Active Exclusions](#)
 - ▶ [Inactive Exclusions](#)
 - ▶ [Excluded Family Members](#)

Entity Overview

Entity Registration Summary

Name: CASPER, CITY OF
Business Type: US Local Government
Last Updated By: Conie Arnold
Registration Status: Active
Activation Date: 03/16/2020
Expiration Date: 03/16/2021

Exclusion Summary

Active Exclusion Records? No

[RETURN TO SEARCH](#)



IBM-P-20200424-1037
WWW5

- [Search Records](#)
- [Disclaimers](#)
- [FAPIS.gov](#)
- [Data Access](#)
- [Accessibility](#)
- [GSA.gov/IAE](#)
- [Check Status](#)
- [Privacy Policy](#)
- [GSA.gov](#)
- [About](#)
- [USA.gov](#)
- [Help](#)

This is a U.S. General Services Administration Federal Government computer system that is "FOR OFFICIAL USE ONLY." This system is subject to monitoring. Individuals found performing unauthorized activities are subject to disciplinary action including criminal prosecution.

RESOLUTION NO. 20-145

A RESOLUTION AUTHORIZING SUBMISSION OF AN APPLICATION TO THE WYOMING DEPARTMENT OF TRANSPORTATION FOR THE FISCAL YEAR 2021 TRANSPORTATION ALTERNATIVES PROGRAM FUNDING FOR THE PARADISE VALLEY TO ROBERTSON ROAD BRIDGE PROJECT.

WHEREAS, the City of Casper desires to construct a pedestrian bridge and ten foot (10') wide concrete pathway connections to the Robertson Road Pathway and the neighborhoods of Paradise Valley; and,

WHEREAS, the Transportation Alternatives Program (TAP) is a federally funded program that is intended to fund projects that will enhance transportation safety, especially for non-motorized transportation enhancements; and,

WHEREAS, the TAP program requires that federal funding criteria be met, and the City of Casper agrees to ensure satisfaction of all requirements; and,

WHEREAS, the City of Casper acknowledges that if funded, the TAP project shall be completed by December 31, 2023; and,

WHEREAS, the City of Casper agrees to set aside a minimum of One Hundred Twenty-Five Thousand Dollars (\$125,000.00) as a line item in its budget for the required twenty percent (20%) local cash match on the project; and,

WHEREAS, the City of Casper acknowledges TAP is funded on a reimbursement basis and all invoices must be one hundred percent (100%) paid by the City of Casper prior to reimbursement through TAP (eighty percent (80%) Federal Reimbursement). The City of Casper acknowledges that failure to comply with this requirement may result in cancellation of the award and repayment by the City of Casper of all funds reimbursed.

NOW, THEREFORE, BE IT RESOLVED BY THE GOVERNING BODY OF THE CITY OF CASPER, WYOMING: That the Mayor is hereby authorized to execute an "Application for Transportation Alternatives Program (TAP) Funding" in the amount of Five Hundred Thousand Dollars (\$500,000.00) for Fiscal Year 2021.

BE IT FURTHER RESOLVED: That the City Engineer or his designee is hereby authorized to submit the TAP grant to the Wyoming Department of Transportation for processing.

PASSED, APPROVED, AND ADOPTED this ____ day of _____, 2020.

APPROVED AS TO FORM:



ATTEST:

Fleur Tremel
City Clerk

CITY OF CASPER, WYOMING
A Municipal Corporation

Steven K. Freel
Mayor

June 16, 2020

MEMO TO: J. Carter Napier, City Manager *JCN*
FROM: Cally Lund, Municipal Court Judge
Michael Szewczyk, IT Manager
SUBJECT: Court Software Replacement

Meeting Type & Date
Council Meeting
July 7, 2020

Action type
Resolution

Recommendation

That Council, by resolution, authorize the purchase of court software and services, in the amount of \$260,397, from Tyler Technologies, Inc.

Summary

Casper Municipal Court has been using its current software platform since 2012. Earlier this year, the vendor informed the City that it was sunsetting the application, and would no longer provide support or maintenance for the system. The City has the option to migrate to the company's new product, which is estimated to cost over \$400,000 in one-time fees and more than a six fold increase in annual maintenance.

The Municipal Court Judge had already been interested in the possibility of migrating the Court software to Tyler Technologies in order to take advantage of integration with the City's new financial system. The proposal by Tyler includes a full featured Court management application, interfaces to Police systems for citations and warrants, and a hosted module for supervising individuals on probation. This project is planned to begin in late summer with a go live in advance of July 1, 2021, the day the current vendor ceases support of its application.

Financial Considerations

Funding for the initial purchase of this effort, \$260,397, is budgeted from capital reserves. Recurring service and maintenance fees will be budgeted in the Municipal Court operating budget for future years, (currently estimated at \$46,411).

Oversight/Project Responsibility

Michael Szewczyk, IT Manager

Attachments

Contract and Resolution



AMENDMENT

This amendment ("Amendment") is effective as of the date of signature of the last party to sign as indicated below ("Amendment Effective Date"), by and between Tyler Technologies, Inc. with offices at One Tyler Drive, Yarmouth, Maine 04096 ("Tyler") and the City of Casper, with offices at 200 North David Street, Casper, Wyoming 82601 ("Client").

WHEREAS, Tyler and the Client are parties to an agreement dated August 7, 2018 ("Agreement"); and

WHEREAS, Tyler and Client desire to amend the terms of the Agreement as provided herein.

NOW THEREFORE, in consideration of the mutual promises hereinafter contained, Tyler and the Client agree as follows:

1. The items set forth in the sales quotation attached as Exhibit 1 to this Amendment are hereby added to the Agreement as of the Amendment Effective Date.
2. Use of the Tyler hosted applications set forth in Exhibit 1 shall be governed by the terms and conditions set forth in Web Services - Hosted Application Terms attached hereto as Exhibit 2 and added to the Agreement as of the Amendment Effective Date.
3. Tyler will provide the implementation services itemized in the Exhibit 1.
4. Upon Client request, and provided a Non-Disclosure Agreement between the parties is in effect, Tyler will provide annual internal controls (SOC) audit reports for the hosted applications and comply with material recommendations that arise from such controls.
5. Payment of fees and costs for items set forth in Exhibit 1 shall conform to the following terms:
 - a. License Fees. License fees will be invoiced when Tyler makes the software added to the Agreement pursuant to this Amendment available for download (for the purpose of this Amendment, the "Available Download Date").
 - b. Maintenance Fees. Year 1 annual maintenance and support fees, prorated for a time period commencing on the Available Download Date and ending at the same time as the end of the then-current annual maintenance term for the Tyler Software already licensed under the Agreement, are due on the Available Download Date. Subsequent annual maintenance fees will be invoiced in accord with the Agreement.
 - c. Services Fees & Expenses. Services added to the Agreement pursuant to this Amendment, along with applicable expenses, shall be invoiced as provided and/or incurred.
 - d. Hardware Fees. Fees for Hardware are due on delivery of the respective Hardware.
 - e. Hosting Fees. Fees for the Tyler hosted applications set forth in Exhibit 1 are invoiced on the Amendment Effective Date. Subsequent fees are due annually in advance of each anniversary thereof at our then-current rates.



6. This Amendment shall be governed by and construed in accordance with the terms and conditions of the Agreement.
7. Except as expressly indicated in this Amendment, all other terms and conditions of the Agreement shall remain in full force and effect.

IN WITNESS WHEREOF, the parties hereto have executed this Amendment as of the dates set forth below.

Tyler Technologies, Inc.

City of Casper

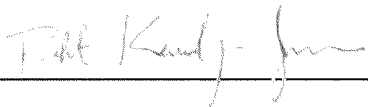
By: 

By: _____

Name: Robert Kennedy-Jensen

Name: Steven K. Freel

Title: Director of Contracts

Title: Mayor, City of Casper

Date: 6/19/2020

Date: 07/07/2020

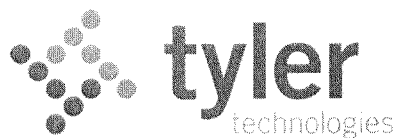

Exhibit 1

The following details the software and services to be delivered by us to you under the Agreement. This Amendment is effective as of the Effective Date. Capitalized terms not otherwise defined will have the meaning assigned to such terms in the Agreement.

In the event a comment in the following sales quotation conflicts with a provision of this Amendment, the provision in this Amendment shall control.

REMAINDER OF PAGE INTENTIONALLY LEFT BLANK



Quoted By: Lee Midkiff
 Quote Expiration: 10/8/2020
 Quote Name: City of Casper-LGD-CT
 Quote Number: 2020-107782
 Quote Description: Municipal Court

Sales Quotation For
 Michael Szewczyk
 City of Casper
 200 N. David
 Casper, WY 82601-1561
 Phone: +1 (307) 235-8317

Tyler Software and Related Services

Description	License	Impl Hours	Impl Cost	Data Conversion	Module Total	Maintenance
Incode Court Suite						
Criminal Court Case Mgt	\$55,000	160	\$20,800	\$47,110	\$122,910	\$13,750
Tyler Jury Module	\$27,500	36	\$4,680	\$0	\$32,180	\$6,875
Cashiering	\$0	8	\$1,040	\$0	\$1,040	\$0
Scheduling	\$8,100	0	\$0	\$0	\$8,100	\$2,025
Officer Email Notification (Generic Interface)	\$4,000	0	\$0	\$0	\$4,000	\$1,000
Citation Issuing Device Interface	\$4,000	0	\$0	\$0	\$4,000	\$1,000
Court/Police (non-Incode) Interface (Import or Export of Citations/Warrants/Dispositions)	\$5,500	0	\$0	\$0	\$5,500	\$1,375
Jury Data Import (Generic Interface)	\$4,400	0	\$0	\$0	\$4,400	\$1,100
Munis GL Interface	\$0	0	\$0	\$0	\$0	\$0
Court Payment Import (Generic Interface)	\$2,500	4	\$520	\$0	\$3,020	\$625
Output Director	\$4,950	8	\$1,040	\$0	\$5,990	\$1,238
<i>Sub-Total:</i>	<i>\$115,950</i>		<i>\$28,080</i>	<i>\$47,110</i>	<i>\$191,140</i>	<i>\$28,988</i>
<i>Less Discount:</i>	<i>\$17,393</i>					<i>\$8,117</i>
TOTAL:	\$98,557	216	\$28,080	\$47,110	\$173,747	\$20,871

Tyler Software and Related Services - Annual

Description	One Time Fees			Annual Fee
	Impl. Hours	Impl. Cost	Data Conversion	
Incode Court Suite				
Court IVR	0	\$0	\$0	\$0
Tyler Supervision (10)	0	\$0	\$0	\$18,000
Tyler Hosted Applications				
Court Online Component	0	\$0	\$0	\$1,800
Notifications for Court	0	\$0	\$0	\$0
Online Record Search	0	\$0	\$0	\$5,000

OpenEdge		0	\$0	\$0	\$0
	<i>Sub-Total:</i>			\$0	\$24,800
	TOTAL:	0	\$0	\$0	\$24,800

Other Services

Description	Quantity	Unit Price	Extended Price	Maintenance
Project Management	2	\$5,000	\$10,000	\$0
Premium Implementation	80	\$130	\$10,400	\$0
TCM Court Training	60	\$130	\$7,800	\$0
Tyler Supervision Setup, Training and Forms	60	\$130	\$7,800	\$0
Online Application -Set up fee	1	\$800	\$800	\$0
	TOTAL:		\$36,800	\$0

3rd Party Hardware, Software and Services

Description	Quantity	Unit Price	Unit Discount	Total Price	Maintenance	Maintenance Discount	Total Maintenance
Canon DR-C225 Sheetfed Scanner - VV7373	1	\$450	\$0	\$450	\$0	\$0	\$0
Epson TM-H6000IV Thermal Receipt Printer - Black, USB NEW	2	\$1,050	\$0	\$2,100	\$420	\$0	\$420
Media Plus Automated Cash Drawer -Black NEW	2	\$250	\$0	\$500	\$80	\$0	\$80
Topaz Fingerprint / Signature Pad TF-LBK464-HSB-R - USB On-Premise Court Sites	2	\$600	\$0	\$1,200	\$240	\$0	\$240
	TOTAL:			\$4,250			\$740

Summary

	One Time Fees	Recurring Fees
Total Tyler Software	\$98,557	\$20,871
Total Tyler Annual	\$0	\$24,800
Total Tyler Services	\$119,990	\$0
Total Third Party Hardware, Software and Services	\$4,250	\$740
Summary Total	\$222,797	\$46,411
Estimated Travel Expenses	\$12,060	

Detailed Breakdown of Conversions (Included in contract total)

Description	Hours	Unit Price	Programming Fee	Extended Price
Incode Court Suite				
Court Case Management -Conversion	40	\$130	\$20,000	\$25,200
Warrants & Judgements -Conversion	8	\$130	\$4,250	\$5,290
Court -Fee Instance, Payment Plans, Restitution -Conversion - Conversion	24	\$130	\$13,500	\$16,620
Tyler Content Manager				
TCM Conversions -Court			\$8,000	\$8,000
	Total:			\$55,110

Comments

- Travel Expenses will be billed as incurred according to Tyler's standard business travel policy.
- Incode Court Online component displays citations for payment, payment plans, payment options, deferred disposition. Make payments, collects pleas from defendants, security SSL(secure socket layer), payment processing (credit card), and payment packet is created to be imported to Court system. Note that the defendant pays \$2.50-\$3.50 fee per transaction for payment on-line.
- Incode Notification for Courts (\$.20 per violation) - defendant notification by phone. Calls can be made for citation issued, court date reminders, court date missed and notification of next step, warrant issued, and payment plan due date reminder etc. Case is updated after each call. Call can be taken live, a message left, or no answer (court creates unique message for each call type and call can be in English or Spanish). The call can go to the attorney rather than the defendant. Incode Notification for Courts (\$.20 per text) - Defendant notification by text. Text can be made for the citation issues, court date reminder, court date missed and notification of next step, warrant issued, and payment plan due date reminder. Note: The Court will be billed by Tyler Technologies quarterly for the calls/texts conducted. The Court will be allowed 2 call campaigns in the first 30 days at no charge. Tyler will assist with the setup and creation of the campaigns. Trial offer is free for 30 days and the campaign is limited to a one year time frame. Both campaigns must be used within the 30 day time frame. If more than 2 campaigns are used, then the customer will be billed for the additional campaigns.
- Court Case Management conversion includes basic case data.
- IVR solution for Court- The payment packet is created in centralized cash collections, the IVR system gives the defendant the balance owed on the citation, the defendant makes the payment by phone and the citation is updated with the payment record. Note: There is a \$2.50 per transaction fee associated with IVR that will be paid by the client unless Tyler is instructed by the client to pass along to the user at time of payment.

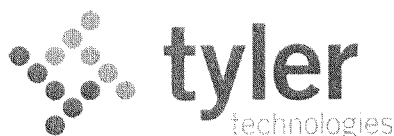

Exhibit 2

Web Services – Hosted Application Terms

Tyler Technologies, Inc. will provide you with the hosted applications indicated in the Investment Summary. The terms and conditions contained in this document only apply to our provision of those applications. Capitalized terms not otherwise defined will have the meaning assigned to such terms in the Agreement.

1. Hosted Applications. We will provide you with any of the following hosted applications as indicated in the Investment Summary.
 - 1.1. *Web Services*: Our Web Services are designed to enable you to easily establish a presence on the Internet. Our Web Hosting and Design is composed of our Web Hosting and Design Publishing Component and other miscellaneous components. These components may be used independently or in conjunction with each other.
 - 1.2. *Utility Billing On-Line*: Our Utility Billing On-Line Component allows you to make available certain information from your utility billing system to citizens with Internet access. This information is posted to your web site, which is hosted on our web server. With the proper security clearance, citizens with Internet access have access to the data which can include: Consumption information, service level information, requests for service, accounting information and the opportunity to pay their Utility Bill over the Internet using a credit card.
 - 1.3. *Court On-Line*: Our Court On-Line Component provides the ability for municipal court fines to be paid by credit card via the Internet. This system interfaces seamlessly with our Incode Municipal Court System.
 - 1.4. *Building Projects On-Line*: Our Building Projects On-Line Component allows you to make available certain information from your building projects system to citizens with Internet access. This information is posted to your web site, which is hosted on our web server. With the proper security clearance, citizens with Internet access have access to the data which can include: Building project status, inspection results, inspection scheduling and the opportunity to pay their building projects over the Internet using a credit card.
 - 1.5. *Business License On-Line*: Our Business License On-Line Component allows you to make available certain information from your business license system to citizens with Internet access. This information is posted to your web site, which is hosted on our web server. With the proper security clearance, citizens with Internet access have access to the data which can include: business license status, business license renewal and the opportunity to pay their business license over the Internet using a credit card.

- 1.6. *Accounts Receivable On-Line*: Our Accounts Receivable On-Line Component allows you to make available certain information from your accounts receivable system to citizens with Internet access. This information is posted to your web site, which is hosted on our web server. With the proper security clearance, citizens with Internet access have access to the data which can include: current balance, contract status, and the opportunity to pay the accounts receivable over the Internet using a credit card.
- 1.7. *Call Center On-Line*: Our Call Center On-Line Component allows you to make available certain information from your call center system to citizens with Internet access. This information is posted to your web site, which is hosted on our web server. With the proper security clearance, citizens with Internet access have access to the data which can include: current and past incidents, create a new incident and view status of incident.
- 1.8. *Property Tax On-Line*: Our Property Tax On-Line Component allows you to make available certain information from your Property Tax System to citizens with Internet access. This information is posted to your web site, which is hosted on our web server. With the proper security clearance, citizens with Internet access have access to the data which can include: parcel number, receipt number, tax amount due, and the opportunity to pay the Property Tax over the Internet using a credit card.
- 1.9. *Sales Tax On-Line*: Our Sales Tax On-Line Component allows you to make available certain information from your Sales Tax System to citizens with Internet access. This information is posted to your web site, which is hosted on our web server. With the proper security clearance, citizens with Internet access have access to the data to pay outstanding Sales Tax balances over the Internet using a credit card.
2. Term. We will grant you access to the hosted applications provided you timely pay all associated fees. The term of your subscription will commence on the Amendment Effective Date and will continue for three (3) years. Thereafter, the term will be automatically extended in separate one (1) year periods. Either party may cancel this subscription to the hosted applications upon sixty (60) days written notice to the other.
3. Nature of Website. We shall maintain a website for you, allowing a user to access relevant data provided by you. This data may include information from your Tyler Software system. This website will be capable of accepting payments via Secured Socket Layer (SSL) encryption and credit card or debit card charge.
4. Data Procurement. You must set up a merchant account with Electronic Transaction System Corporation or authorized.net to be solely used for our Web Service transactions. The merchant account must be set up to fund to your bank account. You are responsible for all fees and expenses of the merchant account. You must install and run Tyler Web Services to allow us to transfer the necessary data from your system to our servers on a real time basis. Certain information, such as payment information, must be conveyed to you. We will be responsible for transferring such information to you on a regular basis. Tyler Web Services requires a dedicated IP address; assignment of this address is your responsibility. While we assume responsibility for data transfer, we are not responsible for accuracy of data transferred.
5. Limited License. Your license to use the hosted applications will automatically terminate upon cancellation of this subscription, or upon your failure to timely pay fees or otherwise comply with these

terms and conditions.

6. Ownership of Data. All data you provide to us for the purposes of generating the website shall remain your property. Should you terminate your subscription, we shall return to you any such data in our possession.
7. Fees. You agree to pay the initial fee and annual subscription fees as stated in the Investment Summary. We may increase the per-transaction fee for online payment no more than once per year with sixty (60) days prior written notice.

APPROVAL AS TO FORM

I have reviewed the attached *Amendment* from Tyler Technologies regarding hosted Municipal Court software, and approve it as to form on behalf of the City of Casper, Wyoming.

Dated: June 22, 2020.



Wallace Trembath III
Deputy City Attorney

RESOLUTION NO.20-146

A RESOLUTION AUTHORIZING A CONTRACT
AMENDMENT BETWEEN THE CITY OF CASPER AND
TYLER TECHNOLOGIES, INC.

WHEREAS, the City of Casper desires to enter into a Contract Amendment with Tyler Technologies, Inc. for Municipal Court software; and,

WHEREAS, Tyler Technologies, Inc. is able and willing to provide the software and associated professional services; and,

WHEREAS, the fees for said software services are set forth in the above referenced Contract Amendment.

NOW, THEREFORE, BE IT RESOLVED BY THE GOVERNING BODY OF THE CITY OF CASPER, WYOMING: That the Mayor is hereby authorized and directed to execute, and the City Clerk to attest, a Contract Amendment in the amount of Two Hundred Sixty Thousand Three Hundred Ninety-Seven Dollars (\$260,397).

BE IT FURTHER RESOLVED: That the City Manager is hereby authorized to make verified partial payments throughout the term of the agreement, in an amount not to exceed Two Hundred Sixty Thousand Three Hundred Ninety-Seven Dollars (\$260,397).

PASSED, APPROVED, AND ADOPTED on this ____ day of _____, 2020.

APPROVED AS TO FORM:



ATTEST:

Fleur Tremel
City Clerk

CITY OF CASPER, WYOMING
A Municipal Corporation

Steven K. Freel
Mayor

June 24, 2020

MEMO TO: J. Carter Napier, City Manager 

FROM: Jolene Martinez, Assistant to the City Manager

SUBJECT: Accepting Grant from the Wyoming Governor's Big Game License Coalition, in the amount of \$10,000, for Wetlands Construction and Enhancement in the First Street Reach River Restoration

Meeting Type & Date

Regular Council Meeting
July 7, 2020

Action type

Resolution

Recommendation

That Council, by resolution, accept a grant from the Wyoming Governor's Big Game Coalition, in the amount of \$10,000, to be used to fund wetlands construction and enhancement.

Summary

Staff was notified on June 23, 2020 that a grant from the Wyoming Governor's Big Game Coalition to fund wetland construction and enhancement in the First Street reach of the river restoration project had been approved. The grant, administered by Wyoming Game and Fish, is awarded from the Wyoming Governor's Big Game Coalition. Staff identified and submitted a grant application to this highly competitive grant opportunity requesting a second grant to cover more of the costs of the same wetlands project that is part of the First Street Reach river restoration project.

In June 2013, Council authorized staff to move forward to secure funding and implement the work identified in the Platte River Environmental Restoration Master Plan. The river restoration effort, which includes a volunteer day every September, is called the Platte River Revival. The projects outlined in the master plan are a combination of riverbank and in-river construction, Russian olive removal, and vegetative plantings. The total cost estimate for riverbank and in-river construction in the seven identified priority areas of the river through Casper is estimated at over \$20 million.

The Platte River Revival is an infrastructure project for Casper and Wyoming that improves water quality; protects drinking water and roadway infrastructure; stabilizes riverbanks; restores and protects green infrastructure; and provides economic development opportunities.

Financial Considerations

No match is required for this grant. However, the grant does not cover 100% of the wetlands construction and enhancement, which is \$35,000. The two Wyoming Governor's Big Game License grants combined will cover \$20,000 of the cost. The additional \$15,000, will be funded by an approved grant from the Wyoming Wildlife and Natural Resource Trust.

Oversight/Project Responsibility

Andrew Beamer, Public Services Director
Scott Baxter, Associate Engineer
Jolene Martinez, Assistant to the City Manager

Attachments

Resolution

**GRANT AGREEMENT
BETWEEN WYOMING GAME AND FISH COMMISSION
AND
CITY OF CASPER**

Grant Agreement No.: 003287
Project Title: First Street Wetlands Project
Award Amount: \$10,000.00
Performance Period: July 1, 2020 through June 30, 2022
PPCAS Code: TW SW0 WGBG 100
Unit: All Wildlife Species Account - F03A - \$10,000.00

Agency Project Coordinator: Justin Binfet, 307-473-3408 / justin.binfet@wyo.gov
Grantee Project Coordinator: Jolene Martinez, 307-235-8332 / jmartinez@casperwy.gov

1. **Parties.** The parties to this Grant Agreement (Agreement) are the Wyoming Game and Fish Commission (Commission), by and through the Wyoming Game and Fish Department (Agency), in cooperation with the Wyoming Governor's Big Game License Coalition, whose address is 5400 Bishop Boulevard, Cheyenne, WY 82006, and City of Casper (Grantee), whose address is 200 North David Street, Casper, WY 82601.
2. **Purpose of Agreement.** The purpose of this Agreement is to set forth the terms and conditions under which the Agency shall provide grant funds to the Grantee to use for projects described herein.
3. **Term of Agreement.** This Agreement is effective when all parties have executed it (Effective Date). The Performance Period of the Agreement is from July 1, 2020 through June 30, 2022. All Services shall be completed during the Performance Period.
4. **Payment.**
 - A. In accordance with Wyo. Stats. §§ 23-1-302 (a)(x) and (a)(xi), and 23-1-501. the Agency hereby grants an amount not to exceed ten thousand dollars and zero cents (\$10,000.00) to the Grantee to perform the activities directly related to the project described herein during the term of this Agreement. At such time as the activities are initiated, the Grantee may invoice the Agency. Payment shall be made within forty-five (45) days after submission of invoice pursuant to Wyo. Stat. § 16-6-602. Grantee shall submit invoices in sufficient detail to ensure that payments may be made in conformance to this Agreement.
 - B. No payment shall be made for work performed outside the Performance Period of this Agreement. Should the Grantee fail to perform in a manner consistent with the terms and conditions set forth in this Agreement. payment under this Agreement

may be withheld until such time as the Grantee performs its duties and responsibilities to the satisfaction of Agency.

- C. Except as otherwise provided in this Agreement, the Grantee shall pay all costs and expenses, including travel, incurred by Grantee or on its behalf in connection with Grantee's performance and compliance with all of Grantee's obligations under this Agreement.

5. **Responsibilities of Grantee.** The Grantee agrees to:

- A. Perform the following project activities:
 - (i) Activities to be performed by the Grantee are as outlined in Attachment A, Project Application, which is attached to and incorporated into this Agreement by this reference, as submitted for consideration and approved by the Wyoming Governor's Big Game License Coalition.
 - (ii) Complete and submit to the Agency Attachment B, WGBGLC Annual Reporting Form, which is attached to this Agreement as and incorporated into this Agreement by this reference.

Reporting due dates are:

Report:	Reporting Period of Performance:	Report Due Date:
Annual Report	7/1/20 – 12/31/20	December 31, 2020
Annual Report	1/1/21 – 12/31/21	December 31, 2021
Final Report	7/1/20 – 6/30/22	September 28, 2022

If the project is completed prior to the end date of the Performance Period, the Final Report will be due within ninety (90) days of project completion.

- B. Utilize grant funds only for the above listed project activities identified in Section 5(A) of this Agreement, and return any unused grant funds no later than ninety (90) days after the grant period or within ninety (90) days after termination of this Agreement by either party.
- C. Maintain adequate accounting records that properly disclose the source and application of grant funds, and make records available for audit by the Agency, Federal awarding agency, Inspectors General, the Comptroller General of the United States, or any of their authorized representatives. Financial records, supporting documents, statistical records, and all other records pertinent to the Federal award must be retained for a period of three (3) years from the date of submission of the final expenditure report in accordance with 2 CFR § 200.333 (Retention requirements for records).

- D. Make any and all project-related information available as requested by the Agency.
- E. Return any equipment purchased with grant funds to the Agency.
- F. Submit to the Agency, upon project completion or within ninety (90) days after the grant termination date, whichever is sooner, a final invoice.

6. **Responsibilities of Agency.** The Agency agrees to:

- A. Make grant funds available as specified in Section 4 above.
- B. Make related information from existing Agency records available to Grantee.

7. **Special Provisions.**

- A. **Assumption of Risk.** The Grantee shall assume the risk of any loss of state or federal funding, either administrative or program dollars, due to the Grantee's failure to comply with state or federal requirements. The Agency shall notify the Grantee of any state or federal determination of noncompliance.
- B. **Certifications.** Acceptance of this grant constitutes certification that:
 - (i) Grantee is not presently debarred, suspended, proposed for disbarment, declared ineligible or voluntarily excluded from covered transactions by any federal department or agency.
 - (ii) Grantee is not delinquent on any federal debt.
 - (iii) To the best of the Grantee's knowledge and belief:
 - (a) No federal appropriated funds have been paid or will be paid, by or on behalf of the Grantee, to any person for influencing or attempting to influence an officer or employee of any agency, a Member of Congress, an officer or employee of congress, or an employee of a Member of Congress in connection with the awarding of any federal contract, the making of any federal grant, the making of any federal loan, the entering into of any cooperative agreement, and the extension, continuation, renewal, amendment, or modification of any federal contract, grant, loan, or cooperative agreement.
 - (b) If funds other than federal appropriated funds have been paid or will be paid to any person for influencing or attempting to influence an officer or employee of any agency, a Member of Congress, an officer or employee of Congress, or an employee of a Member of Congress in connection with this federal contract, grant, loan or

cooperative agreement, the Grantee will complete and submit Standard Form – LLL (Disclosure of Lobbying Activities).

- C. Conflict of Interest Disclosures.** Grantee shall comply with the requirements of 2 CFR § 200.112 (Conflict of Interest). Grantee is responsible for notifying Agency in writing of any actual or potential conflicts of interest that may arise during the life of this award. This Agreement may be terminated if Agency discovers an undisclosed conflict of interest.
- D. Copyright License and Patent Rights.** Grantee acknowledges that the federal grantor, the State of Wyoming, and Agency reserve a royalty-free, nonexclusive, unlimited, and irrevocable license to reproduce, publish, or otherwise use, and to authorize others to use, for federal and state government purposes: (1) the copyright in any work developed under this Agreement; and (2) any rights of copyright to which Grantee purchases ownership using funds awarded under this Agreement. Grantee must consult with Agency regarding any patent rights that arise from, or are purchased with, funds awarded under this Agreement.
- E. Drug-Free Workplace.** Grantee shall comply with the requirements of the Drug-Free Workplace Act of 1988, 42 U.S.C. § 701 *et seq.* and 2 CFR part 1401, which require all programs and activities receiving federal assistance to maintain a drug-free workplace.
- F. Environmental Policy Acts.** Grantee agrees all activities under this Agreement will comply with the Clean Air Act, the Clean Water Act, the National Environmental Policy Acts, and other related provisions of federal environmental protection laws, rules or regulations, if applicable.
- G. Human Trafficking.** As required by 22 U.S.C. § 7104(g) and 2 CFR Part 175, this Agreement may be terminated without penalty if a private entity that receives funds under this Agreement:
- (i) Engages in severe forms of trafficking in persons during the period of time that the award is in effect;
 - (ii) Procures a commercial sex act during the period of time that the award is in effect; or
 - (iii) Uses forced labor in the performance of the award or subawards under the award.
- H. Kickbacks.** Grantee certifies and warrants that no gratuities, kickbacks, or contingency fees were paid in connection with this Agreement, nor were any fees, commissions, gifts, or other considerations made contingent upon the award of this

Agreement. If Grantee breaches or violates this warranty, Agency may, at its discretion, terminate this Agreement without liability to Agency, or deduct from the agreed upon price or consideration, or otherwise recover, the full amount of any commission, percentage, brokerage, or contingency fee.

- I. **Monitoring Activities.** Agency shall have the right to monitor all activities related to this Agreement that are performed by Grantee or its subgrantees. This shall include, but not be limited to, the right to make site inspections at any time and with reasonable notice; to bring experts and consultants on site to examine or evaluate completed work or work in progress; to examine the books, ledgers, documents, papers, and records pertinent to this Agreement; and to observe personnel in every phase of performance of Agreement related work.

- J. **Nondiscrimination.** Grantee shall comply with the Civil Rights Act of 1964, the Wyoming Fair Employment Practices Act (Wyo. Stat. § 27-9-105 *et seq.*), the Americans with Disabilities Act (ADA), 42 U.S.C. § 12101, *et seq.*, and the Age Discrimination Act of 1975 and any properly promulgated rules and regulations thereto and shall not discriminate against any individual on the grounds of age, sex, color, race, religion, national origin, or disability in connection with the performance under this Agreement.

- K. **Prior Approval Requirements.** Grantee shall comply with the requirements of 2 CFR § 200.407 and notify Agency of any changes that have a significant impact on the award-supported activities or in the case of problems, delays, or adverse conditions which materially impair the ability to meet the objectives of the award, changes in scope, time extensions, budget revisions, changes in key personnel, etc.

- L. **Procurement Standards.** Grantee's procurement procedures must conform to applicable federal and state laws and the standards identified in 2 CFR § 200.318 through 2 CFR § 200.326.

8. **General Provisions.**

- A. **Amendments.** Any changes, modifications, revisions, or amendments to this Agreement which are mutually agreed upon by the parties to this Agreement shall be incorporated by written instrument, executed by all parties to this Agreement.

- B. **Applicable Law, Rules of Construction, and Venue.** The construction, interpretation, and enforcement of this Agreement shall be governed by the laws of the State of Wyoming, without regard to conflicts of law principles. The terms "hereof," "hereunder," "herein," and words of similar import, are intended to refer to this Agreement as a whole and not to any particular provision or part. The Courts of the State of Wyoming shall have jurisdiction over this Agreement and the parties. The venue shall be the First Judicial District, Laramie County, Wyoming.

- C. Assignment Prohibited and Agreement Shall Not be Used as Collateral.** Neither party shall assign or otherwise transfer any of the rights or delegate any of the duties set out in this Agreement without the prior written consent of the other party. The Grantee shall not use this Agreement, or any portion thereof, for collateral for any financial obligation without the prior written permission of the Agency.
- D. Availability of Funds.** Each payment obligation of the Agency is conditioned upon the availability of government funds which are appropriated or allocated for the payment of this obligation and which may be limited for any reason including, but not limited to, congressional, legislative, gubernatorial, or administrative action. If funds are not allocated and available for continued performance of the Agreement, the Agreement may be terminated by the Agency at the end of the period for which the funds are available. The Agency shall notify the Grantee at the earliest possible time of the services which will or may be affected by a shortage of funds. No penalty shall accrue to the Agency in the event this provision is exercised, and the Agency shall not be obligated or liable for any future payments due or for any damages as a result of termination under this section.
- E. Compliance with Laws.** The Grantee shall keep informed of and comply with all applicable federal, state, and local laws and regulations in the performance of this Agreement.
- F. Counterparts.** This Agreement may be executed in counterparts. Each counterpart, when executed and delivered, shall be deemed an original and all counterparts together shall constitute one and the same Agreement. Delivery by the Grantee of an originally signed counterpart of this Agreement by facsimile or PDF shall be followed up immediately by delivery of the originally signed counterpart to the Agency.
- G. Entirety of Agreement.** This Agreement, consisting of nine (9) pages: Attachment A, Project Application, consisting of nineteen (19) pages; and Attachment B, WBGGLC Annual Reporting Form, consisting of one (1) page, represent the entire and integrated Agreement between the parties and supersede all prior negotiations, representations, and agreements, whether written or oral. In the event of a conflict or inconsistency between the language of this Agreement and the language of any attachment or document incorporated by reference, the language of this Agreement shall control.
- H. Force Majeure.** Neither party shall be liable for failure to perform under this Agreement if such failure to perform arises out of causes beyond the control and without the fault or negligence of the nonperforming party. Such causes may include, but are not limited to, acts of God or the public enemy, fires, floods, epidemics, quarantine restrictions, freight embargoes, and unusually severe weather. This provision shall become effective only if the party failing to perform

immediately notifies the other party of the extent and nature of the problem, limits delay in performance to that required by the event, and takes all reasonable steps to minimize delays.

- I. **Grant Recovery.** The Agency shall be entitled to recover from the Grantee any full or partial payment made under this Agreement for: 1) any payments used for purposes not authorized or performed outside this Agreement, 2) any payments for project work the Grantee is unable to provide, or 3) any payments for project work the Grantee did not provide but was required to provide under the terms of this Agreement.
- J. **Indemnification.** Each party to this Agreement shall assume the risk of any liability arising from its own conduct. Neither party agrees to insure, defend, or indemnify the other.
- K. **Independent Contractor.** The Grantee shall function as an independent contractor for the purposes of this Agreement and shall not be considered an employee of the State of Wyoming for any purpose. Consistent with the express terms of this Agreement, the Grantee shall be free from control or direction over the details of the performance of services under this Agreement. The Grantee shall assume sole responsibility for any debts or liabilities that may be incurred by the Grantee in fulfilling the terms of this Agreement and shall be solely responsible for the payment of all federal, state, and local taxes which may accrue because of this Agreement. Nothing in this Agreement shall be interpreted as authorizing the Grantee or its agents or employees to act as an agent or representative for or on behalf of the State of Wyoming or the Agency or to incur any obligation of any kind on behalf of the State of Wyoming or the Agency. The Grantee agrees that no health or hospitalization benefits, workers' compensation, unemployment insurance, or similar benefits available to State of Wyoming employees will inure to the benefit of the Grantee or the Grantee's agents or employees as a result of this Agreement.
- L. **Notices.** All reports, forms, notices and communications arising out of, or from, the provisions of this Agreement shall be in writing and directed to the attention of the Agency's or Grantee's contact person either by regular mail or delivery in person at the addresses provided under this Agreement.
- M. **Prior Approval.** This Agreement shall not be binding upon either party, no services shall be performed, and the Wyoming State Auditor shall not draw warrants for payment, until this Agreement has been fully executed and approved as to form by the Office of the Attorney General.
- N. **Sovereign Immunity and Limitations.** Pursuant to Wyo. Stat. § 1-39-104(a), the State of Wyoming, the Commission, and Agency expressly reserve sovereign immunity by entering into this Agreement and the Grantee expressly reserves governmental immunity. Each of them specifically retains all immunities and

defenses available to them as sovereigns or governmental entities pursuant to Wyo. Stat. § 1-39-101, *et seq.*, and all other applicable law. The parties acknowledge that the State of Wyoming has sovereign immunity and only the Wyoming Legislature has the power to waive sovereign immunity. Designations of venue, choice of law, enforcement actions, and similar provisions shall not be construed as a waiver of sovereign immunity. The parties agree that any ambiguity in this Agreement shall not be strictly construed, either against or for either party, except that any ambiguity as to immunity shall be construed in favor of immunity.

- O. Taxes.** Grantee shall pay all taxes and other such amounts required by federal, state, and local law, including, but not limited to, federal and social security taxes, workers' compensation, unemployment insurance, and sales taxes.
- P. Termination of Agreement.** This Agreement may be terminated if Grantee fails to perform in accordance with the terms of this Agreement. The Agency will provide Grantee written notice of intent to impose immediate measures and will make reasonable efforts to resolve the problem informally.
- Q. Third-Party Beneficiary Rights.** The parties do not intend to create in any other individual or entity the status of third-party beneficiary, and this Agreement shall not be construed so as to create such status. The rights, duties, and obligations contained in this Agreement shall operate only between the parties to this Agreement and shall inure solely to the benefit of the parties to this Agreement. The provisions of this Agreement are intended only to assist the parties in determining and performing their obligations under this Agreement.
- R. Enhancement of Recipient and Subrecipient Employee Whistleblower Protection.**

 - (i) This award, related subawards, and related contracts over the simplified acquisition threshold and all employees working on this award, related subawards, and related contracts over the simplified acquisition threshold are subject to the whistleblower rights and remedies established at 41 U.S.C. § 4712.
 - (ii) Recipients, their subrecipients, and their contractors awarded contracts over the simplified acquisition threshold related to this award, shall inform their employees in writing, in the predominant language of the workforce, of the employee whistleblower rights and protections under 41 U.S.C. § 4712.
 - (iii) The recipient shall insert this clause, including this paragraph (iii), in all subawards and in contracts over the simplified acquisition threshold related to this award.

THE REMAINDER OF THIS PAGE WAS INTENTIONALLY LEFT BLANK.

- 9. **Signatures.** The parties to this Agreement, either personally or through their duly authorized representatives, have executed this Agreement on the dates set out below, and certify that they have read, understood, and agreed to the terms and conditions of this Agreement.

The Effective Date of this Agreement is the date of signature last affixed to this page.

WYOMING GAME AND FISH COMMISSION

 John Kennedy, Deputy Director
 Wyoming Game and Fish Department

Date

 Meredith Wood, Chief Fiscal Officer

Date

GRANTEE:
City of Casper

 Steven K. Freel, Mayor
 Authorized Signatory for Grantee

Date

DUNS Number

ATTORNEY GENERAL'S OFFICE: APPROVAL AS TO FORM

Tyler M. Renner
 _____ # 204214
 for: Tyler M. Renner, Assistant Attorney General

6/22/2020

Date

CITY ATTORNEY'S OFFICE: APPROVAL AS TO FORM

Wallace Trembath

 Wallace Trembath, Deputy City Attorney

6/25/2020

Date

Attachment A - Project Application

Email address	jmartinez@casperwy.gov
Project lead:	Jolene Martinez
Phone number:	307.235.8332
Organization:	Other, provide information below
If other, list the name of the organization and mailing address	City of Casper, 200 N David St, Casper, WY 82601
Species group funding:	All wildlife
Project type:	Habitat or Conservation Easement
Project Description	
Project title:	First Street Wetlands Project
Project location:	Natrona, Casper, 13N391117 4745024
Project phase :	Phase 1 of 1
Project timeline and estimated completion date (explain):	Naturally occurring wetlands have been delineated and evaluated. City engineering staff has mapped and evaluated all stormwater outfalls in the river reach. Design for the First Street Reach including wetland enhancement and creation and outfall redirection is 100% complete. The project has been bid and awarded. The first half of the river restoration project has been completed and a timeline with contract change order is in the progress for the second half. Funding is in place for the contracted elements and additional funding is being sought so that the elements removed due to lack of funding can be constructed, too. Construction, dependent on river flow, will begin by October 1, 2020 and be completed by early December 2020. Seeding and landscaping will occur in spring 2021.
Miles or acres directly affected:	18 acres
List any statewide or national initiatives this project will be associated with:	Strategic Habitat Plan and Wyoming Wetlands Conservation Strategy
	The First Street Wetlands Project is a wetlands construction and enhancement project within the First Street reach of the larger river restoration construction project for the Casper portion of the North Platte River. The restoration project is named Platte River Revival. During river restoration construction in fall 2020, wetlands will be created or enhanced. Wetlands are a critical

component of the Platte River Revival both for their importance to the river ecosystem and for their ability prevent water pollution by filtering the stormwater outfalls. One of the strategies for wetlands within the river restoration effort is to construct wetlands to filter stormwater from the outfalls where space permits. When space does not permit, low-flow cleaning manholes are added to the outfall to reduce water pollution.

Project narrative:

The First Street reach is located on the edge of Casper's downtown and is a 2,400 lineal feet reach of the North Platte River and its associated riparian area from the Poplar Street bridge to the BNSF bridge. The First Street bridge divides the reach. Additional funding is respectfully being requested for the First Street Wetlands Project. This project was fortunate and honored to receive Wyoming Governor's Big Game License Coalition funding in 2019. However, the bid for the entire river restoration was over budget and over available funding. Several original elements including realignment of a stormwater outfall to a wetland had to be removed. Because the second half of the construction project, where the wetlands are located, had to be delayed, there is an opportunity to find more funding to include the removed elements. In this case, a second award from WGBGLC would enable the Platte River Revival Advisory Committee to redirect city infrastructure funding from the wetlands construction to use for both leverage for additional funding and for additional funding toward adding back in one of the outfall realignments taken out of the project due to lack of funding. Should WGBGLC fund this 2020 request, the funding will be added to the 2019 funding and all WGBGLC funding will be focused on enhancing marginal quality wetlands and creating two additional wetlands per project design documents. Three stormwater outfalls in this second half of river reach will be directed to the wetlands for contaminant filtering. This does not include the outfall realignment that can hopefully be added back to the project.

In order to achieve the goal of constructing and/or enhancing wetlands for wildlife benefit and to filter stormwater from outfalls in the First Street reach, the stamped design will be followed by the contractor. Success will be measured by the design drawings that document how the wetlands were designed; the as-built drawings that will document the actual construction; the number of acres of wetlands created and enhanced; the net wetland gain; and the results of monitoring the wetlands to document whether they are functioning. Outcomes from the First Street Wetlands Project include increased habitat for wetland and riparian species including waterfowl and shore birds; improved fish health; increased aquatic plants; decreased volumes of stormwater reaching the river unfiltered; reduced nutrient and sediment loads reaching the river; and increased opportunities to bird watch, nature explore, wildlife watch, and more. There is also an educational opportunity to teach the general public about the importance of wetlands to Wyoming wildlife, especially as the project is being constructed.

The First Street Wetlands Project is part of the larger North

Describe any current or future monitoring plans:	Platte River restoration project. The project is a collaboration lead by the City of Casper, Wyoming Game and Fish, BLM, Natrona County Weed and Pest, and Two Fly Foundation. Up to 35 private organizations and business also participate. Monitoring plans are in conjunction with the lead collaborators and are part of City of Casper, Wyoming Game and Fish and Natrona County Weed and Pest operations and maintenance.
Total project cost:	First Street Wetlands total cost is \$55,000.
Total WGBGLC funding requested:	\$10,000 is being requested from the All Species Fund.
Details for matching funds anticipated in cash:	WGBGLC 2019, \$10,000, received and in hand; City of Casper, \$20,000 received and in hand; WGF Commission Trust Fund, \$15,000 received, pending.
Details for in-kind matching funds:	There are no in-kind funds for First Street Wetlands Project.
Is NEPA required? If so, when will NEPA be approved?	NEPA is not required.
List contact information (name, and phone number) for each affected private surface owner or surface management agency:	Surface management agency is the City of Casper in consultation with Wyoming Game and Fish. The contact for the City of Casper is Scott Baxter, Associate Engineer, 307.235.8341.
Attachments and supporting documentation:	Project design Map
Additional information for consideration:	Funding from the Wyoming Governor's Big Game License Grant will be used solely for the costs associated with constructing two wetlands and enhancing the existing marginal wetlands delineated as part of the design process in the First Street Reach. Costs include excavation, clearing and grubbing, and seeding and planting. The costs for the First Street Wetlands Project were extracted from the contract bid tab. All of the line items are for direct wetlands construction costs: labor, equipment, and materials. The Wyoming Governor's Big Game License Coalition has been integral to the accomplishment of several important project components of the entire river restoration since 2015 including leadership funding for the Morad Park Wetlands Sub-Project in 2015, the Aquatic Habitat Side Channel in 2016, Russian olive removal and citizen science monitoring in critical riparian areas in 2017 and 2018, and the First Street reach wetlands in 2019. One of the outcomes of Russian olive removal has been the return of naturally occurring wetlands. The Platte River Revival Advisory Committee is very grateful for the funding the WGBGLC has given to the Platte

River Revival and the trust it has placed in the Platte River Revival Advisory Committee as good stewards. Because the Governor's Big Game License Coalition funding has respect amongst other funders, the Platte River Revival Advisory Committee has been able to successfully leverage the Coalition grants for needed additional project funding and expects to do so again on the stormwater outfall realignment. To date, the Platte River Revival has a net wetland gain of 8.5 acres from river restoration work completed. This project will add an additional 0.31 net wetland gain. To continue to highlight the importance of wetlands for wildlife habitat and water pollution prevention from stormwater outfalls, the Platte River Revival Advisory Committee humbly and respectfully asks the Wyoming Governor's Big Game License Coalition to join 2020 funding with 2019 funding and continue funding wetland gains in the Casper portion of the North Platte River.

River Restoration - First Street Wetlands Project

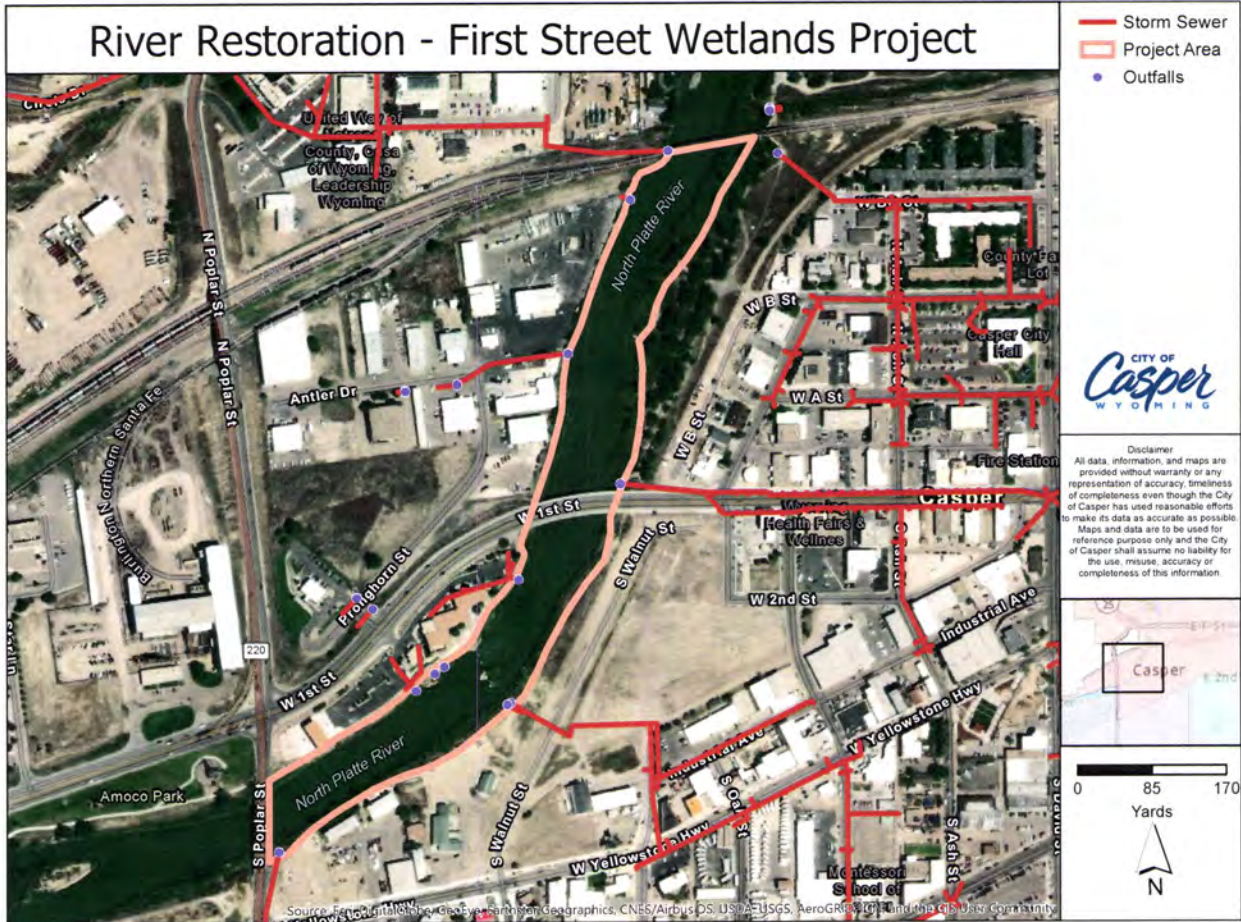

CITY OF CASPER

STATE	PROJECT NO.	SHEET NO.	TOTAL SHEETS
WY	172621100	COVER	45

NORTH PLATTE RIVER RESTORATION FIRST STREET REACH

**MAY 2019
100% DESIGN
NATRONA COUNTY, WYOMING**

Sheet List Table	
Sheet Number	Sheet Title
COVER	COVER SHEET
NOTES	GENERAL NOTES
EX-OV	EXISTING PLAN
OV-1	SITE PLAN
PP-1	PLAN AND PROFILE 1
PP-2	PLAN AND PROFILE 2
PP-3	PLAN AND PROFILE 3
WET-PP-1	WETLAND AREA 1 PLAN
WET-PP-2	WETLAND AREA 2 PLAN AND PROFILE
DET-01	BAR VANE DETAIL
DET-02	W BAR VANE DETAIL
DET-03	WOOD TOE DETAIL
DET-04	BOULDER VANE DETAIL
DET-05	WILLOW WATTLE GRADE CONTROL DETAIL
DET-06	BOAT RAMP AND ACCESS ROAD DETAIL
DET-07	BOULDER CLUSTER DETAIL
DET-08	ARMORED INNER BERM DETAIL
DET-09	RUBBLE REMOVAL DETAIL
XS-1	CROSS SECTIONS
XS-2	CROSS SECTIONS
XS-3	CROSS SECTIONS

XS-4	CROSS SECTIONS
XS-5	CROSS SECTIONS
XS-6	CROSS SECTIONS
WC-1	ACCESS AND WATER CONTROL OVERVIEW
WC-2	ACCESS AND WATER CONTROL SEQUENCING
ESC-OV	EROSION AND SEDIMENTATION PLAN OVERVIEW
ESC-1	EROSION AND SEDIMENTATION PLAN
ESC-2	EROSION AND SEDIMENTATION PLAN
ESC-DET-01	EROSION AND SEDIMENT CONTROL DETAILS
ESC-DET-02	EROSION AND SEDIMENT CONTROL DETAILS
ESC-DET-03	EROSION AND SEDIMENT CONTROL DETAILS
L-OV	LANDSCAPING OVERVIEW
L-1	LANDSCAPING PLAN
L-2	LANDSCAPING PLAN
L-3	LANDSCAPING PLAN
L-4	LANDSCAPING PLAN
L-5	LANDSCAPING PLAN
L-6	LANDSCAPING PLAN
L-7	LANDSCAPING PLAN
SS-1	OUTFALL A
SS-2	OUTFALL B
SS-3	OUTFALL C 1
SS-4	OUTFALL C 2
SS-5	STORMWATER NOTES AND DETAILS

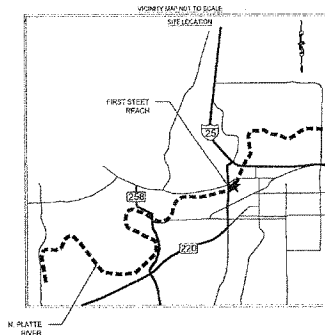

NO.	DESCRIPTION

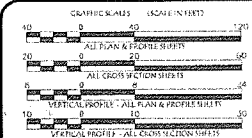

PROJECT LENGTH
REGULATION 1.25 MI FT

Prepared by:

Stantec Consulting Services Inc.
3328 South Timberline Road, Suite 150
Fort Collins, Colorado 80505
www.stantec.com

Professional Engineer
Timothy Dinkins
Project Engineer

Prepared for:

Scott Baxter
PROJECT MANAGER

EXISTING LEGEND

- EXISTING WETLAND
- EXISTING RIPRAP
- EXISTING CONCRETE UNFORD BANK
- EXISTING GABION BASKETS
- EXISTING RAVINE
- EXISTING TREE
- EXISTING ROAD/DRIVEWAY
- EXISTING FENCE LINE
- EXISTING RIP BARRIER WALL
- EXISTING STORM WATER PIPE
- ORSM
- EXISTING MONITORING WELLS
- PROPERTY LINE
- WATER LINE
- OVERHEAD UTILITY LINE
- GAS LINE
- MAJOR EXISTING CONTOUR
- MINOR EXISTING CONTOUR
- EXISTING BANKFULL CHANNEL LIMITS

PROPOSED LEGEND

- NATIVE COBBLE
- SELECT MATERIAL
- RIPRAP RIPRAP GRATING WITH SELECT MATERIAL
- PROPOSED BOAT RAMP
- PROPOSED BOULDER
- PROPOSED WOOD POLE
- OUTFLOW CHANNEL LIMIT
- PROPOSED BANKFULL CHANNEL LIMITS
- MAJOR PROPOSED CONTOUR
- PROPOSED BASELINE ALIGNMENT
- PROPOSED BASELINE ALIGNMENT
- UNITS OF DISTURBANCE

PROFILE LEGEND

- PROPOSED BASELINE PROFILE
- PROPOSED BANKFULL PROFILE
- EXISTING SURFACE AT EXISTING PROFILE
- EXISTING SURFACE AT CENTERLINE PROFILE

BOULDER SIZING		
	N	S
15	33	30

Select Material Gradation		
3/8" Sieve	4.75" Sieve	Intermediate Sieve Dimensions (in)
100%	100%	10
100%	100%	12
100%	100%	15
100%	100%	18
100%	100%	24

Select Material Mixing Requirements

Appropriate Applications (See Volume)	Material Description
0 Part	1/4" - 1/2" Native Rock (Cleaned rock with 100% passing 4 inch sieve, 50-90% passing 3/4 inch sieve, 0-10% passing 1/2 inch sieve)
1 Part	1/2" - 3/4" Riprap (Riprap with rock and sand well graded, 70-100% passing 4" sieve, 70-90% passing 1.5" sieve, 40-60% passing 3/8" sieve, 10-30% passing #10 sieve)
2 Part	1/2" - 3/4" Riprap (Cleaned rock with 100% passing 4" sieve, 50-90% passing 3/4" sieve, 0-20% passing #10 sieve)
3 to 4 Part	Native Rock

*NOTE: IMPROVED MATERIAL SHALL BE MIXED WITH LOCAL ALLUVIAL SAND TO FORM CHANNEL SUBSTRATE FOR CHANNEL RECONSTRUCTION RESTRICTIONS DESCRIBED ABOVE.

- GENERAL NOTES:**
- DRAWINGS BASED ON FIELD SURVEY AS PERFORMED BY CEPI DATED DECEMBER 3, 2018. THE LOWEST SURFACE DATA WAS VERIFIED BY CEPI DATED DEC 3, 2018. ALL DRAWINGS ARE REFERENCED TO NAVD83 PLANE COORDINATE SYSTEM. PROPERTY LINES AND CONVEYANCE LIMITS OF CONSTRUCTION ACTIVITIES UNLESS NOTED ON THE PLANS OR APPROVED BY THE OWNER.
 - ALL WORK SHALL BE IN ACCORDANCE WITH CITY OF CASPER STANDARD SPECIFICATIONS AND DETAILS UNLESS FURTHER SPECIFIED IN THESE PLANS AND SPECIFICATIONS.
 - CONTRACTOR SHALL INSPECT SITE PRIOR TO START OF WORK. VERIFY EXISTING CONDITIONS MATCH PLANS AND ACCEPT SITE. ON REPORT ANY DISCREPANCIES IMMEDIATELY TO THE ENGINEER.
 - ANY DISCREPANCIES IN PLANS, OR DEPARTURE FROM PLANS SHALL BE REPORTED TO THE ENGINEER IMMEDIATELY. AND NO WORK SHALL CONTINUE ON THE AFFECTED AREA UNTIL CORRECTED BY THE ENGINEER.
 - CONTRACTOR IS RESPONSIBLE FOR SCHEDULING ALL PRE-CONSTRUCTION MEETINGS WITH ALL APPLICABLE GOVERNING JURISDICTIONS.
 - THE CONTRACTOR IS RESPONSIBLE FOR OBTAINING ALL NECESSARY PERMITS TO COMMENCE WORK. A SECTION 404 PERMIT HAS BEEN OBTAINED FOR THE PROJECT FROM THE USACE. NO WORK SHALL BE BEGUN UNTIL ALL PERMITS ARE IN HAND.
 - THE CONTRACTOR IS RESPONSIBLE FOR COORDINATION AND IDENTIFICATION OF UTILITIES ON-SITE. ONE CALL OF ANYTHING SHALL BE NOTIFIED BY CONTRACTOR (OR 1-800-848-4478) IF OUT-OF-STATE) AT LEAST TWO BUSINESS DAYS BEFORE EXCAVATION CAN BEGIN.
 - THE CONTRACTOR IS RESPONSIBLE FOR COORDINATING ALL DISUSE OR MANAGEMENT OF TRAIL/PEDESTRIAN TRAFFIC IN CONJUNCTION WITH THESE CONSTRUCTION ACTIVITIES.
 - THE CONTRACTOR WILL MAKE EVERY EFFORT TO AVOID AND MINIMIZE DAMAGE TO ANY INFRASTRUCTURE, UTILITIES, AND PRIVATE PROPERTY ADJACENT TO THE PROJECT AREA. ANY DAMAGE SHALL BE REPAIRED IMMEDIATELY AND BE THE SOLE RESPONSIBILITY OF THE CONTRACTOR.
 - CONTRACTOR SHALL KEEP JOB SITE FREE OF TRASH AND DEBRIS, AND SHALL IMMEDIATELY COLLECT ANY CONSTRUCTION-RELATED DEBRIS OR TRASH THAT IS OR IS DIRECTLY ADJACENT TO THE PROJECT SITE.
 - ALL SOIL EROSION CONTROL MEASURES REQUIRED BY THE EROSION CONTROL PLANS SHALL BE PERFORMED PRIOR TO GRADING, CLEARING OR GRUBBING. ALL EROSION CONTROL DEVICES SUCH AS SILT FENCES, ETC. SHALL BE MAINTAINED IN WORKABLE CONDITIONS FOR THE LIFE OF THE PROJECT. AND SHALL BE REMOVED AT THE COMPLETION OF THE PROJECT OR AS PER THE OWNER'S APPROVAL.
 - IF ANY EROSION CONTROL MEASURES FOR STABILITY AND OPERATION ON SLOPE 1:1 OR WITHIN 24 HOURS AFTER ANY SIGNIFICANT STORM EVENT.
 - REMOVE SETTLEMENT FROM BEHIND SILT FENCE. MARK THE DEPTH REACHES 15 FEET. SETTLEMENT SHALL BE DISPOSED ON THE PROJECT ONLY IN PROTECTION AREAS OR HALLED AWAY IF NOT SUITABLE FOR FILL MATERIAL.
 - IF ANY EROSION CONTROL MEASURE IS FOUND TO BE UNUSABLE OR NOT FUNCTIONING PROPERLY, REPAIRS SHOULD BE DONE IMMEDIATELY TO MAINTAIN MEASURES AS DESIGNED OR AS DIRECTED BY THE ENGINEER.
 - THE CONTRACTOR SHALL CONTROL ALL DUST BY PERIODIC WATERING AND SHALL PROVIDE ACCESS AT ALL TIMES FOR PROPERTY OWNERS WITHIN THE PROJECT AREA AND FOR EMERGENCY VEHICLES. ALL OPEN DITCHES AND HAZARDOUS AREAS SHALL BE CLEARLY MARKED IN ACCORDANCE WITH GOVERNING REGULATORY BODIES.
 - THE CONTRACTOR SHALL ENTER AND EXIT THE SITE VIA THE TEMPORARY CONSTRUCTION ENTRANCES AS DETAILED IN THE DRAWINGS.
 - PREVENT SPILLING OF FUELS, LUBRICANTS, COOLANTS, HYDRAULIC FLUIDS, AND ANY OTHER PETROLEUM PRODUCTS ONTO THE GROUND OR INTO SURFACE WATERS. DISPOSE OF SPENT FUELS

- APPROPRIATELY, AS PER LAW, THE CONTRACTOR IS RESPONSIBLE FOR ALL COSTS ASSOCIATED WITH HAZARDOUS MATERIAL TABLE INCLUDING REMEDIATION.
- THE CONTRACTOR IS RESPONSIBLE FOR PROJELET SURVEY INCLUDING STRAIN AND STRUCTURE LAYOUT. ALL STRAINING WORK SHALL BE DONE BY A LICENSED SURVEYOR REGISTERED IN THE STATE OF WYOMING.
 - REPAIRS TO GRADES TO FINISHES SHALL BE AS NOTED IN THESE PLANS AND THE SPECIFICATIONS. THE ENGINEER MAY MAKE GRADE CHANGES AS REQUIRED IN THE FIELD WITHOUT EFFECTING THE UNIT BID PRICE FOR UNDESIGNED ELEVATION.
 - IN-STREAM WORK SHALL BE CONSTRUCTED FROM THE UPSTREAM WORKING IN THE DOWNSTREAM DIRECTION. CONSTRUCT THE PROPOSED STREAM CHANNEL TO THE GRADE SPECIFIED.
 - CONSTRUCT ONLY A PORTION OF THE CHANNEL THAT CAN BE COMPLETED AND STABILIZED WITHIN THE SAME DAY. ONLY NEW CHANNEL WORK SHALL BE PROTECTED WITH REED, STRAW, COYNEER MATTING, AND LIME STAKES. ALL OTHER DISTURBED AREAS SHALL BE PROTECTED WITH REED, PASTURE AND STRAW.
 - ANY AREAS NOT DESIGNATED FOR CHANGE SHALL BE MAINTAINED TO PRE-PROJECT CONDITIONS UNLESS NOTIFIED BY THE ENGINEER OR OWNER.
 - THE CONTRACTOR IS RESPONSIBLE TO READ, REVIEW, AND FOLLOW THE REQUIREMENTS AND PROTOCOLS OUTLINED IN THE CONTAMINANT RELEASE MITIGATION PLAN.
- CONSTRUCTION SEQUENCE:**
- ALL EROSION CONTROL BARRIERS AND IN-STREAM RELEASE CONTROLS WILL BE INSTALLED PRIOR TO CONSTRUCTION ACCESS INTO THE NORTH PLATE REACH.
 - WORK WILL PROCEED FROM UPSTREAM TO DOWNSTREAM REACH, WITH REACH 1 BEING THE FIRST TO BE CONSTRUCTED.
 - PRELIMINARY ACCESS AND STAGING AREAS FOR THE PROJECT, DESCRIBED ON THE ATTACHED SITE ACCESS FIGURE, WILL BE ESTABLISHED AND SECURED.
 - 3 BED SAMPLES WILL BE EXCAVATED FROM LOCATIONS SLATED FOR EXCAVATION IN THE REACH DOWNSTREAM OF THE FLY FISHERMAN STATUS REACH 2) AND ANALYZED FOR SUITABILITY AS ACCEPTABLE (i.e. "CLEAN") FILL MATERIAL. THE SAMPLES WILL BE VISUALLY INSPECTED FOR PRESENCE OF OIL, GREASE OR COLOR AND WILL BE SCREENED USING A PHOTO IONIZATION DETECTOR (PID) TO MEASURE A SAMPLE OF THE SOIL USING STANDARD HEADSPACE ANALYSIS PROTOCOLS OR "DIRTY" IN SOIL (FIELD TEST KIT).
 - IF THE MATERIAL IS FOUND TO BE "CLEAN" AS A RESULT OF THIS ANALYSIS, THE CONTRACTOR WILL UTILIZE LOCALLY HARVESTED AND ENGINEER APPROVED BED MATERIAL TO FILL THE ACCESS ROAD AS SHOWN ON THE SITE ACCESS FIGURE TO REACH 1. IMPORTED SELECT MATERIAL MAY BE NECESSARY AS SUPPLEMENTAL BANK MATERIAL TO COMPLETE CREATION OF THE ACCESS ROAD.
 - THE ACCESS ROAD WILL SERVE AS THE PRIMARY ROUTE FOR THE MOVEMENT OF CONSTRUCTION EQUIPMENT TO AND FROM REACH 1.
 - RED AND BANK GRADING ON RIVERBANK, UPSTREAM OF THE FLY FISHERMAN STATUS, HAS BEEN MAINTAINED IN DESIGN SO AS TO NOT DEGRADE EXISTING INFRASTRUCTURE. ANY RED OR BANK CONSTRUCTION CONDUCTED IN REACH 1 WILL BE PERFORMED IN ISOLATION (i.e. IN THE DRY) THROUGH IMPLEMENTATION OF COPPER DAMS OR SIMILAR STRUCTURES).
 - ALL EXCAVATED MATERIAL FROM REACH 1 WILL BE HALLED OFF, REMOVED FROM THE PROJECT SITE, AND DISPOSED IN APPROVED LOCATION IDENTIFIED BY THE CITY OF CASPER MUNICIPAL SOLID WASTE MANAGER. ALL BED AND BANK MATERIAL FILL IN REACH 1 WILL BE IMPORTED FROM APPROVED ON-SITE LOCATIONS OR FROM AN APPROVED OFF-SITE SOURCE.
 - ONCE WORK WITHIN REACH 1 IS COMPLETE AND NO FURTHER RIVERBANK DISTURBANCE WILL OCCUR, CONSTRUCTION WILL PROCEED IN THE DOWNSTREAM DIRECTION.



Client/Project:
CITY OF CASPER
200 NORTH DAVID STREET | CASPER, WY 82401

Revision	By	Date
1	JK	11/15/23
2	JK	11/15/23
3	JK	11/15/23
4	JK	11/15/23
5	JK	11/15/23
6	JK	11/15/23
7	JK	11/15/23
8	JK	11/15/23
9	JK	11/15/23
10	JK	11/15/23
11	JK	11/15/23
12	JK	11/15/23
13	JK	11/15/23
14	JK	11/15/23
15	JK	11/15/23
16	JK	11/15/23
17	JK	11/15/23
18	JK	11/15/23
19	JK	11/15/23
20	JK	11/15/23

Permit Seal

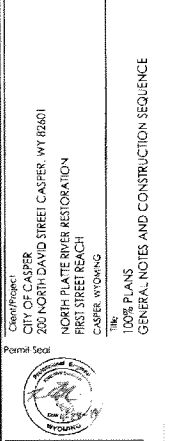

Project Number: 1726211.10

Scale: 1" = 10'-0"

Drawing No: _____

Revision: _____

Sheet: _____

Notes: _____

Attachment A to the Grant Agreement
between Wyoming Game and Fish Commission
and City of Casper
Page 7 of 19



225 S. Fremont Blvd., Suite 4100
 Fort Collins, Colorado 80526
 www.stantec.com

NO.	DATE	BY	APP'D	DESCRIPTION
1	10/20/10	JK	JK	ISSUED FOR PERMIT
2	11/15/10	JK	JK	REVISIONS
3	12/15/10	JK	JK	REVISIONS
4	01/15/11	JK	JK	REVISIONS
5	02/15/11	JK	JK	REVISIONS
6	03/15/11	JK	JK	REVISIONS
7	04/15/11	JK	JK	REVISIONS
8	05/15/11	JK	JK	REVISIONS
9	06/15/11	JK	JK	REVISIONS
10	07/15/11	JK	JK	REVISIONS
11	08/15/11	JK	JK	REVISIONS
12	09/15/11	JK	JK	REVISIONS
13	10/15/11	JK	JK	REVISIONS
14	11/15/11	JK	JK	REVISIONS
15	12/15/11	JK	JK	REVISIONS
16	01/15/12	JK	JK	REVISIONS
17	02/15/12	JK	JK	REVISIONS
18	03/15/12	JK	JK	REVISIONS
19	04/15/12	JK	JK	REVISIONS
20	05/15/12	JK	JK	REVISIONS
21	06/15/12	JK	JK	REVISIONS
22	07/15/12	JK	JK	REVISIONS
23	08/15/12	JK	JK	REVISIONS
24	09/15/12	JK	JK	REVISIONS
25	10/15/12	JK	JK	REVISIONS
26	11/15/12	JK	JK	REVISIONS
27	12/15/12	JK	JK	REVISIONS
28	01/15/13	JK	JK	REVISIONS
29	02/15/13	JK	JK	REVISIONS
30	03/15/13	JK	JK	REVISIONS
31	04/15/13	JK	JK	REVISIONS
32	05/15/13	JK	JK	REVISIONS
33	06/15/13	JK	JK	REVISIONS
34	07/15/13	JK	JK	REVISIONS
35	08/15/13	JK	JK	REVISIONS
36	09/15/13	JK	JK	REVISIONS
37	10/15/13	JK	JK	REVISIONS
38	11/15/13	JK	JK	REVISIONS
39	12/15/13	JK	JK	REVISIONS
40	01/15/14	JK	JK	REVISIONS
41	02/15/14	JK	JK	REVISIONS
42	03/15/14	JK	JK	REVISIONS
43	04/15/14	JK	JK	REVISIONS
44	05/15/14	JK	JK	REVISIONS
45	06/15/14	JK	JK	REVISIONS
46	07/15/14	JK	JK	REVISIONS
47	08/15/14	JK	JK	REVISIONS
48	09/15/14	JK	JK	REVISIONS
49	10/15/14	JK	JK	REVISIONS
50	11/15/14	JK	JK	REVISIONS
51	12/15/14	JK	JK	REVISIONS
52	01/15/15	JK	JK	REVISIONS
53	02/15/15	JK	JK	REVISIONS
54	03/15/15	JK	JK	REVISIONS
55	04/15/15	JK	JK	REVISIONS
56	05/15/15	JK	JK	REVISIONS
57	06/15/15	JK	JK	REVISIONS
58	07/15/15	JK	JK	REVISIONS
59	08/15/15	JK	JK	REVISIONS
60	09/15/15	JK	JK	REVISIONS
61	10/15/15	JK	JK	REVISIONS
62	11/15/15	JK	JK	REVISIONS
63	12/15/15	JK	JK	REVISIONS
64	01/15/16	JK	JK	REVISIONS
65	02/15/16	JK	JK	REVISIONS
66	03/15/16	JK	JK	REVISIONS
67	04/15/16	JK	JK	REVISIONS
68	05/15/16	JK	JK	REVISIONS
69	06/15/16	JK	JK	REVISIONS
70	07/15/16	JK	JK	REVISIONS
71	08/15/16	JK	JK	REVISIONS
72	09/15/16	JK	JK	REVISIONS
73	10/15/16	JK	JK	REVISIONS
74	11/15/16	JK	JK	REVISIONS
75	12/15/16	JK	JK	REVISIONS
76	01/15/17	JK	JK	REVISIONS
77	02/15/17	JK	JK	REVISIONS
78	03/15/17	JK	JK	REVISIONS
79	04/15/17	JK	JK	REVISIONS
80	05/15/17	JK	JK	REVISIONS
81	06/15/17	JK	JK	REVISIONS
82	07/15/17	JK	JK	REVISIONS
83	08/15/17	JK	JK	REVISIONS
84	09/15/17	JK	JK	REVISIONS
85	10/15/17	JK	JK	REVISIONS
86	11/15/17	JK	JK	REVISIONS
87	12/15/17	JK	JK	REVISIONS
88	01/15/18	JK	JK	REVISIONS
89	02/15/18	JK	JK	REVISIONS
90	03/15/18	JK	JK	REVISIONS
91	04/15/18	JK	JK	REVISIONS
92	05/15/18	JK	JK	REVISIONS
93	06/15/18	JK	JK	REVISIONS
94	07/15/18	JK	JK	REVISIONS
95	08/15/18	JK	JK	REVISIONS
96	09/15/18	JK	JK	REVISIONS
97	10/15/18	JK	JK	REVISIONS
98	11/15/18	JK	JK	REVISIONS
99	12/15/18	JK	JK	REVISIONS
100	01/15/19	JK	JK	REVISIONS

Client/Project
 CITY OF CASPER
 200 NORTH DAVID STREET CASPER, WY 82401
 NORTH PLATTE RIVER RESTORATION
 FIRST STREET REACH
 CASPER, WYOMING

THE
 100% PLANS
 EXISTING PLAN

Permit-Stamp



Project Number: 172621110
 File Name: 100% Existing Dr. Aug.
 HW: JLA MFL WJS
 Date: 07/15/18 Page: 11 of 100
 Drawing No.
 Revision Sheet
 0 EX-0V

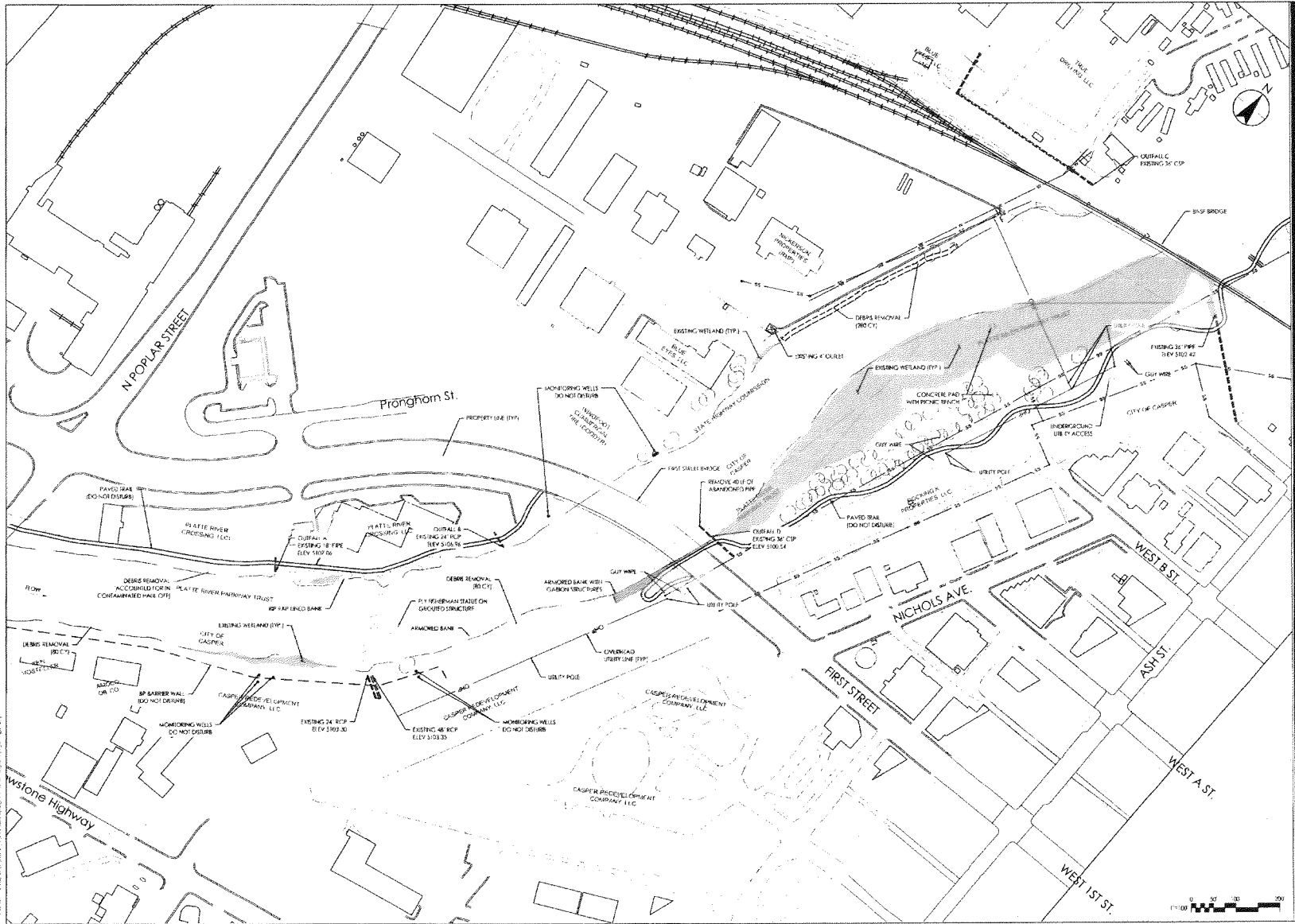



3333 Township Road, Suite 4100
 Fort Collins, Colorado 80525
 www.stantec.com

NO.	DATE	REVISION
1	11/11/10	ISSUED FOR PERMITS
2	01/11/11	ISSUED FOR PERMITS
3	03/11/11	ISSUED FOR PERMITS
4	05/11/11	ISSUED FOR PERMITS
5	07/11/11	ISSUED FOR PERMITS
6	09/11/11	ISSUED FOR PERMITS
7	11/11/11	ISSUED FOR PERMITS
8	01/12/12	ISSUED FOR PERMITS
9	03/12/12	ISSUED FOR PERMITS
10	05/12/12	ISSUED FOR PERMITS
11	07/12/12	ISSUED FOR PERMITS
12	09/12/12	ISSUED FOR PERMITS
13	11/12/12	ISSUED FOR PERMITS
14	01/13/13	ISSUED FOR PERMITS
15	03/13/13	ISSUED FOR PERMITS
16	05/13/13	ISSUED FOR PERMITS
17	07/13/13	ISSUED FOR PERMITS
18	09/13/13	ISSUED FOR PERMITS
19	11/13/13	ISSUED FOR PERMITS
20	01/14/14	ISSUED FOR PERMITS
21	03/14/14	ISSUED FOR PERMITS
22	05/14/14	ISSUED FOR PERMITS
23	07/14/14	ISSUED FOR PERMITS
24	09/14/14	ISSUED FOR PERMITS
25	11/14/14	ISSUED FOR PERMITS
26	01/15/15	ISSUED FOR PERMITS
27	03/15/15	ISSUED FOR PERMITS
28	05/15/15	ISSUED FOR PERMITS
29	07/15/15	ISSUED FOR PERMITS
30	09/15/15	ISSUED FOR PERMITS
31	11/15/15	ISSUED FOR PERMITS
32	01/16/16	ISSUED FOR PERMITS
33	03/16/16	ISSUED FOR PERMITS
34	05/16/16	ISSUED FOR PERMITS
35	07/16/16	ISSUED FOR PERMITS
36	09/16/16	ISSUED FOR PERMITS
37	11/16/16	ISSUED FOR PERMITS
38	01/17/17	ISSUED FOR PERMITS
39	03/17/17	ISSUED FOR PERMITS
40	05/17/17	ISSUED FOR PERMITS
41	07/17/17	ISSUED FOR PERMITS
42	09/17/17	ISSUED FOR PERMITS
43	11/17/17	ISSUED FOR PERMITS
44	01/18/18	ISSUED FOR PERMITS
45	03/18/18	ISSUED FOR PERMITS
46	05/18/18	ISSUED FOR PERMITS
47	07/18/18	ISSUED FOR PERMITS
48	09/18/18	ISSUED FOR PERMITS
49	11/18/18	ISSUED FOR PERMITS
50	01/19/19	ISSUED FOR PERMITS
51	03/19/19	ISSUED FOR PERMITS
52	05/19/19	ISSUED FOR PERMITS
53	07/19/19	ISSUED FOR PERMITS
54	09/19/19	ISSUED FOR PERMITS
55	11/19/19	ISSUED FOR PERMITS
56	01/20/20	ISSUED FOR PERMITS
57	03/20/20	ISSUED FOR PERMITS
58	05/20/20	ISSUED FOR PERMITS
59	07/20/20	ISSUED FOR PERMITS
60	09/20/20	ISSUED FOR PERMITS
61	11/20/20	ISSUED FOR PERMITS
62	01/21/21	ISSUED FOR PERMITS
63	03/21/21	ISSUED FOR PERMITS
64	05/21/21	ISSUED FOR PERMITS
65	07/21/21	ISSUED FOR PERMITS
66	09/21/21	ISSUED FOR PERMITS
67	11/21/21	ISSUED FOR PERMITS
68	01/22/22	ISSUED FOR PERMITS
69	03/22/22	ISSUED FOR PERMITS
70	05/22/22	ISSUED FOR PERMITS
71	07/22/22	ISSUED FOR PERMITS
72	09/22/22	ISSUED FOR PERMITS
73	11/22/22	ISSUED FOR PERMITS
74	01/23/23	ISSUED FOR PERMITS
75	03/23/23	ISSUED FOR PERMITS
76	05/23/23	ISSUED FOR PERMITS
77	07/23/23	ISSUED FOR PERMITS
78	09/23/23	ISSUED FOR PERMITS
79	11/23/23	ISSUED FOR PERMITS
80	01/24/24	ISSUED FOR PERMITS
81	03/24/24	ISSUED FOR PERMITS
82	05/24/24	ISSUED FOR PERMITS
83	07/24/24	ISSUED FOR PERMITS
84	09/24/24	ISSUED FOR PERMITS
85	11/24/24	ISSUED FOR PERMITS
86	01/25/25	ISSUED FOR PERMITS
87	03/25/25	ISSUED FOR PERMITS
88	05/25/25	ISSUED FOR PERMITS
89	07/25/25	ISSUED FOR PERMITS
90	09/25/25	ISSUED FOR PERMITS
91	11/25/25	ISSUED FOR PERMITS
92	01/26/26	ISSUED FOR PERMITS
93	03/26/26	ISSUED FOR PERMITS
94	05/26/26	ISSUED FOR PERMITS
95	07/26/26	ISSUED FOR PERMITS
96	09/26/26	ISSUED FOR PERMITS
97	11/26/26	ISSUED FOR PERMITS
98	01/27/27	ISSUED FOR PERMITS
99	03/27/27	ISSUED FOR PERMITS
100	05/27/27	ISSUED FOR PERMITS

Client/Project:
 CITY OF CASPER
 200 NORTH DAVID STREET CASPER, WY 82401
 NORTH PLATE RIVER RESTORATION
 FIRST STREET BEACH
 CASPER, WYOMING

Permit/Spec:
 THE
 100% PLANS
 SITE PLAN

Project Number: 17291110
 www.stantec.com
 Drawing No: 01-1000-01
 Revision: 0
 Sheet: 01-1000-01

Attachment A to the Grant Agreement
 between Wyoming Game and Fish Commission
 and City of Casper
 Page 9 of 19

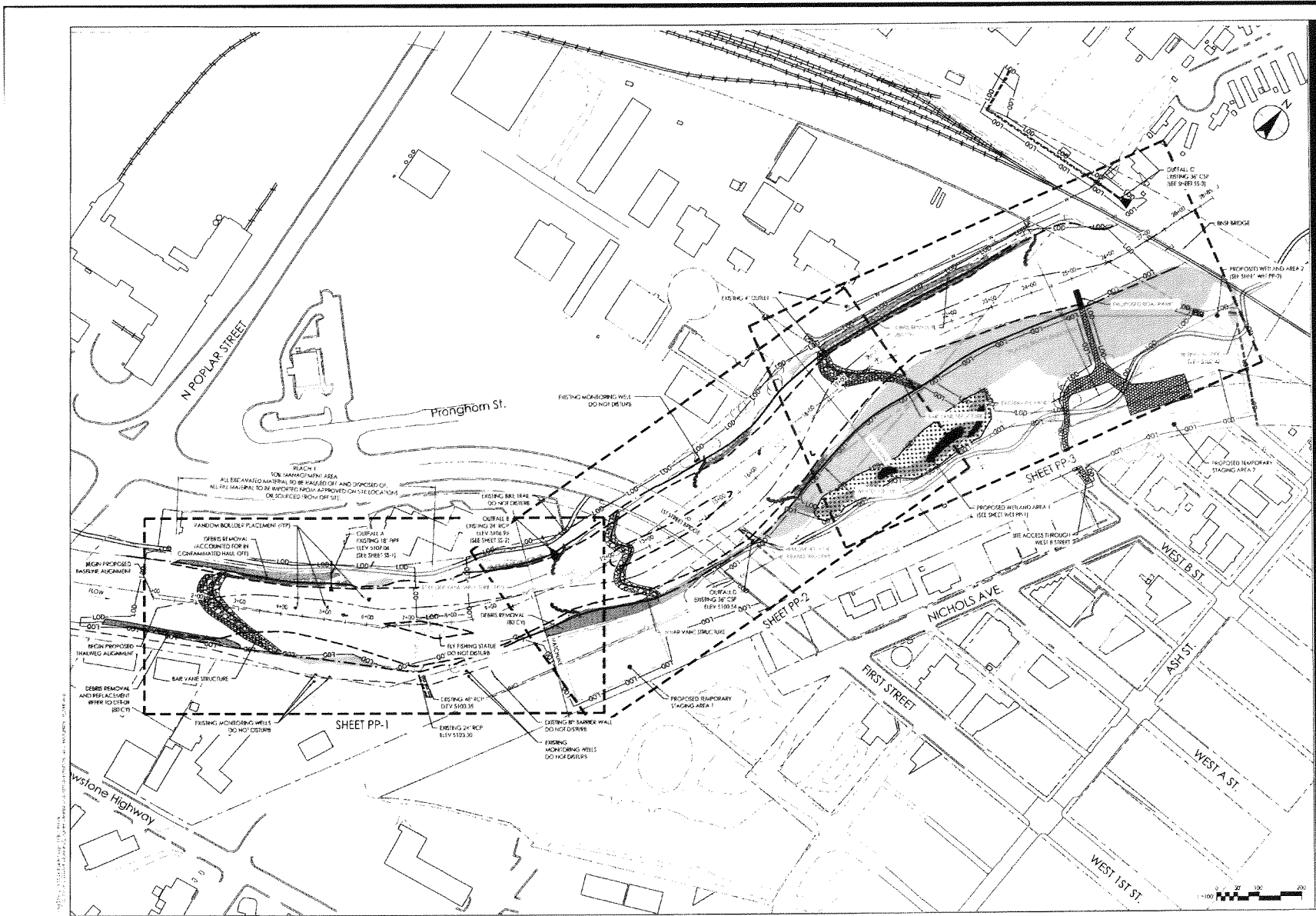

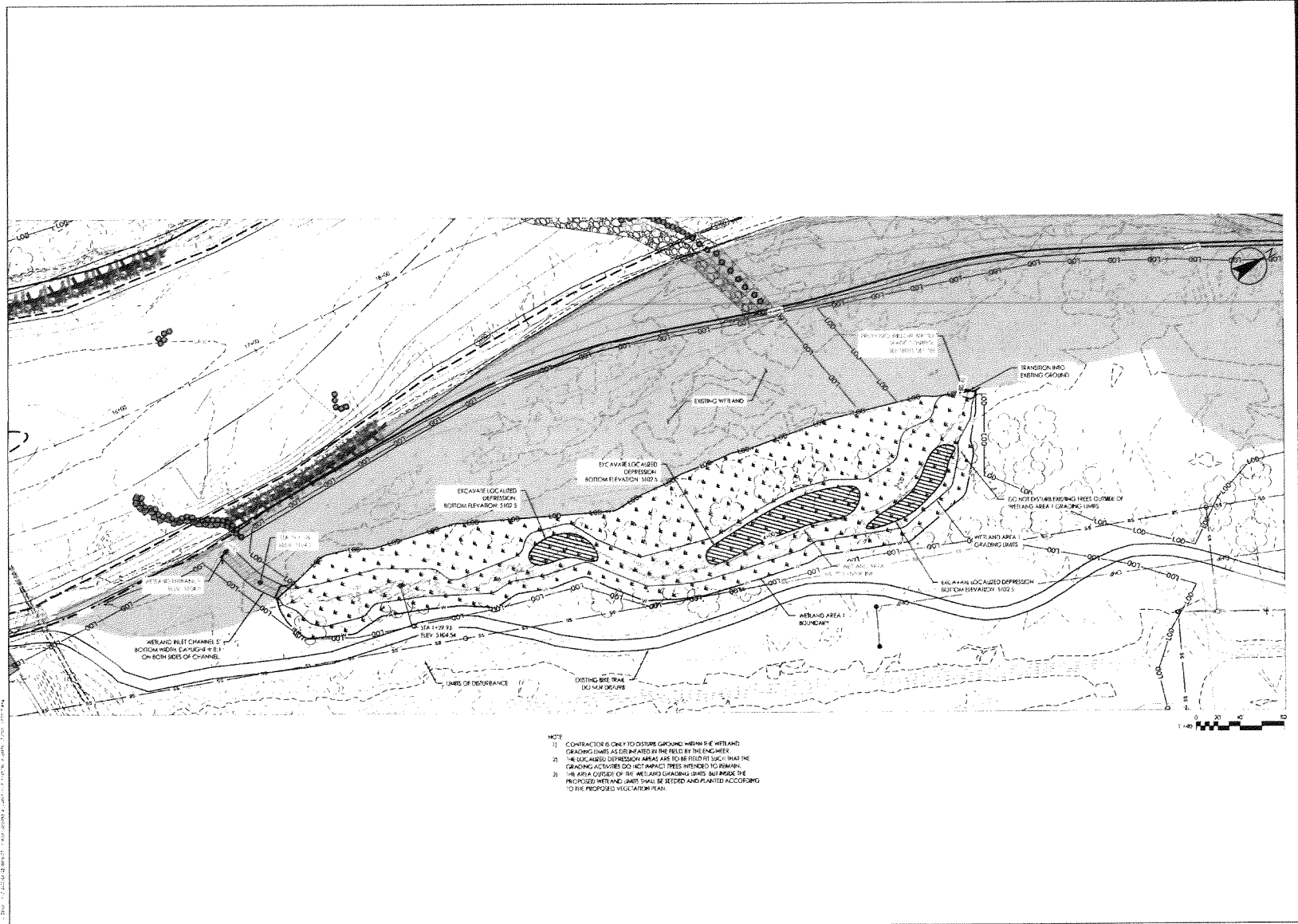

NOTE

- 1) CONSTRUCTION IS ONLY TO OCCUR WITHIN THE WETLAND GRADING LIMITS AS DETERMINED BY THE ENGINEER.
- 2) THE LOCALIZED DEPRESSION AREAS ARE TO BE FLOTTED SUCH THAT THE GRADING ACTIVITIES DO NOT IMPACT TREES REFERRED TO ROWING.
- 3) THE AREA OUTSIDE OF THE WETLAND GRADING LIMITS BUT INSIDE THE PROPOSED WETLAND LIMITS SHALL BE SEEDING AND PLANTED ACCORDING TO THE PROPOSED VEGETATION PLAN.



Revision	No.	DATE	BY	CHKD	APP'D
	0				

CLIENT
 CITY OF CASPER
 220 NORTH DAVID STREET CASPER, WY 82402
 NORTH PLATE RIVER RESTORATION
 FIRST STREET REACH
 CASPER, WYOMING

THIS DRAWING IS THE PROPERTY OF STANTEC INC. IT IS TO BE USED ONLY FOR THE PROJECT AND SITE SPECIFICALLY IDENTIFIED HEREIN. IT IS NOT TO BE REPRODUCED, COPIED, OR TRANSMITTED IN ANY FORM OR BY ANY MEANS, ELECTRONIC OR MECHANICAL, INCLUDING PHOTOCOPYING, RECORDING, OR BY ANY INFORMATION STORAGE AND RETRIEVAL SYSTEM, WITHOUT THE WRITTEN PERMISSION OF STANTEC INC.

Permit-Set

Project Number: 172621110

DATE	DESCRIPTION	BY	CHKD	APP'D

Drawing No. _____
 Revision _____ Sheet _____
 0 WET PP-1

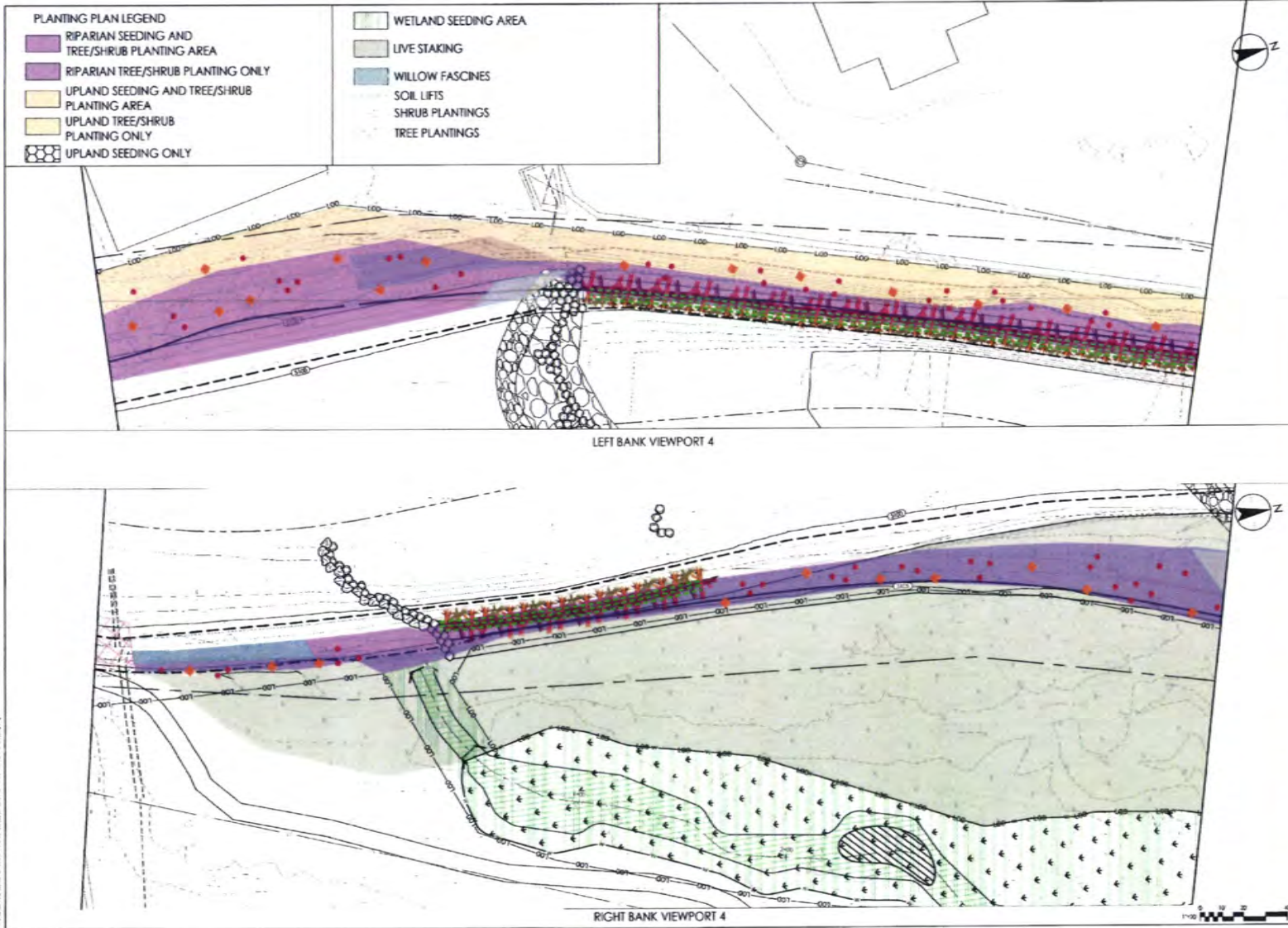

- PLANTING PLAN LEGEND**
- RIPARIAN SEEDING AND TREE/SHRUB PLANTING AREA
 - RIPARIAN TREE/SHRUB PLANTING ONLY
 - UPLAND SEEDING AND TREE/SHRUB PLANTING AREA
 - UPLAND TREE/SHRUB PLANTING ONLY
 - UPLAND SEEDING ONLY

- WETLAND SEEDING AREA
- LIVE STAKING
- WILLOW FASCINES
- SOIL LIFTS
- SHRUB PLANTINGS
- TREE PLANTINGS



Rev	Date	By	App
1	11/14/18	JK	JK
2	11/14/18	JK	JK

Client/Project:
 CITY OF CASPER
 200 NORTH DAVID STREET CASPER, WY 82401
 NORTH PLATTE RIVER RESTORATION
 FOST STREET REACH
 CASPER, WY 82401

Permit/Spec:
 Title:
 100% PLANS
 LANDSCAPING PLAN

Project Number: 172671110
 City Agency: WPCD - LANDSCAPING PLAN
 Date: 11/14/18
 Drawn: JK
 Check: JK
 Title: 100% PLANS
 Drawing No. LANDSCAPING PLAN
 Sheet L-4



Revision	By	Date

Client/Project:
CITY OF CASPER
200 NORTH DAVID STREET CASPER, WY 82401
NORTH PLATTE RIVER RESTORATION
FIRST STREET BEACH
CASPER, WY 82401

Title:
100% PLANS
LANDSCAPING PLAN

Project Number: 172621110
 Date: 04/03/2018
 Drawing No: LANDSCAPING PLAN
 Sheet: 1 of 4

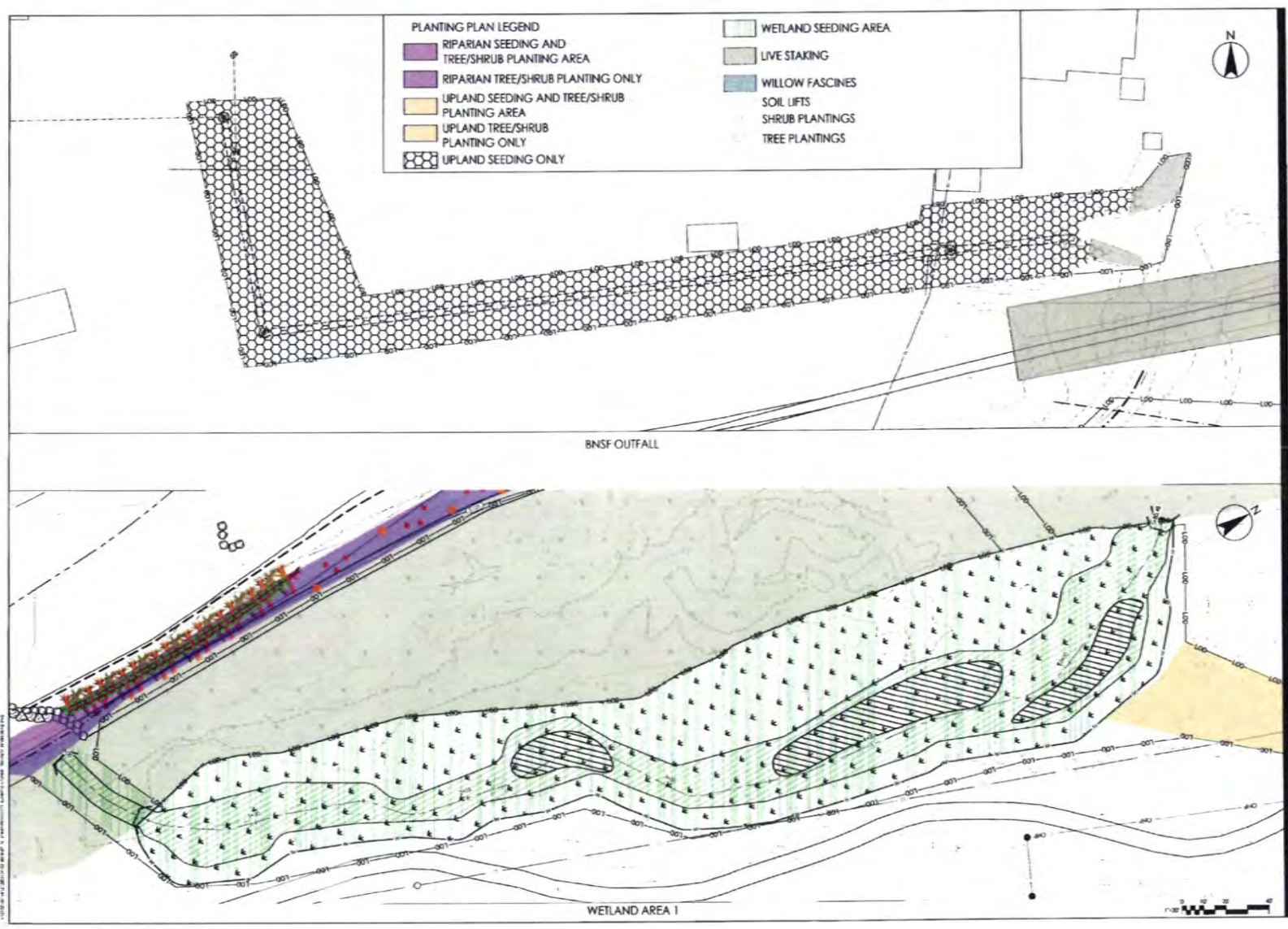

- PLANTING PLAN LEGEND**
- RIPARIAN SEEDING AND TREE/SHRUB PLANTING AREA
 - RIPARIAN TREE/SHRUB PLANTING ONLY
 - UPLAND SEEDING AND TREE/SHRUB PLANTING AREA
 - UPLAND TREE/SHRUB PLANTING ONLY
 - UPLAND SEEDING ONLY
 - WETLAND SEEDING AREA
 - LIVE STAKING
 - WILLOW FASCINES
 - SOIL LIFTS
 - SHRUB PLANTINGS
 - TREE PLANTINGS

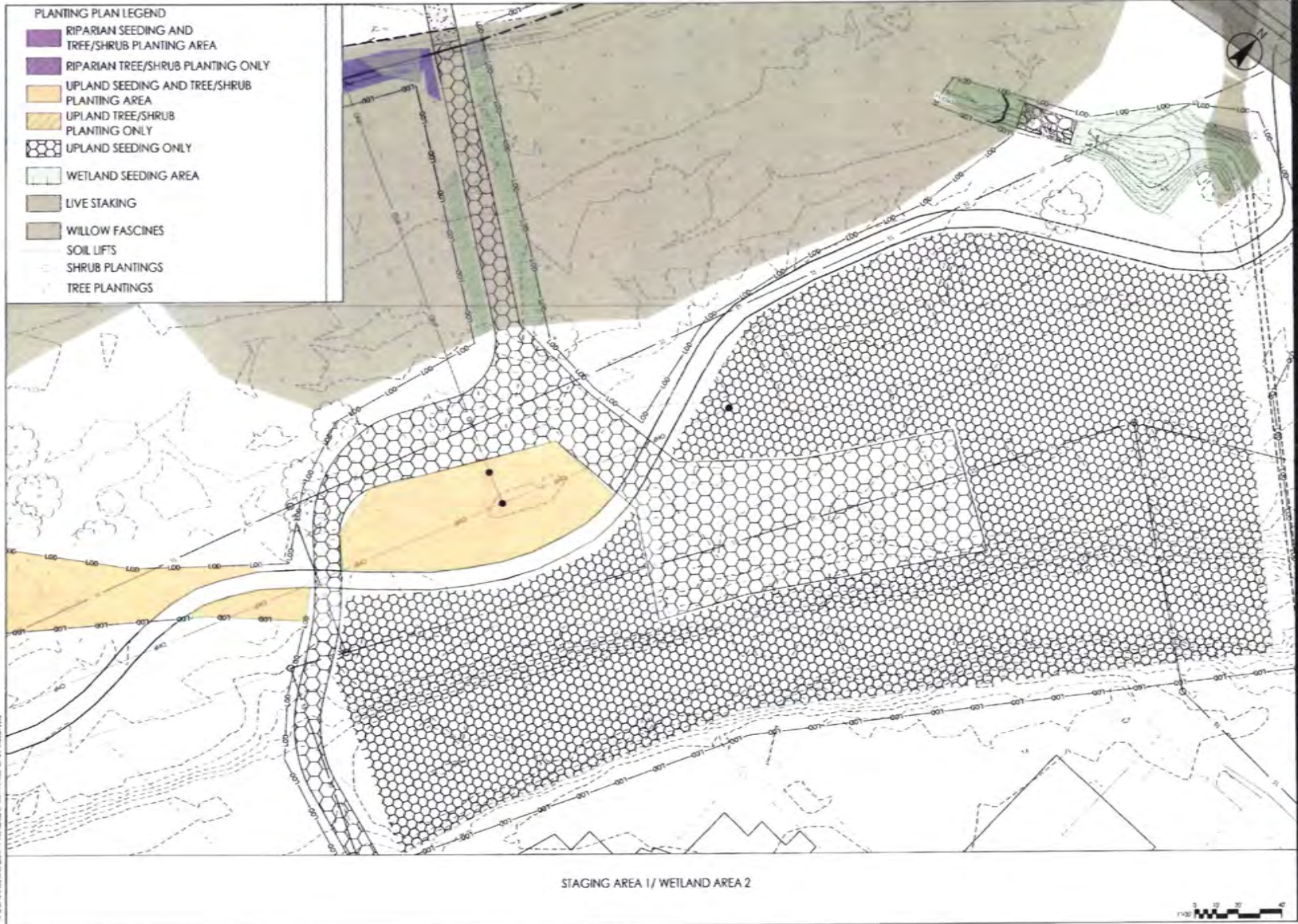

Stantec
 323 South Indiana Avenue, Suite 100
 Fort Collins, Colorado 80526-3920
 Phone: 970.226.8000
 Fax: 970.226.8001
 www.stantec.com

NO.	DATE	REVISION
1	11/11/2011	ISSUED FOR PERMITS
2	01/10/2012	REVISED PER COMMENTS
3	02/01/2012	REVISED PER COMMENTS
4	02/01/2012	REVISED PER COMMENTS
5	02/01/2012	REVISED PER COMMENTS
6	02/01/2012	REVISED PER COMMENTS
7	02/01/2012	REVISED PER COMMENTS
8	02/01/2012	REVISED PER COMMENTS
9	02/01/2012	REVISED PER COMMENTS
10	02/01/2012	REVISED PER COMMENTS
11	02/01/2012	REVISED PER COMMENTS
12	02/01/2012	REVISED PER COMMENTS
13	02/01/2012	REVISED PER COMMENTS
14	02/01/2012	REVISED PER COMMENTS
15	02/01/2012	REVISED PER COMMENTS
16	02/01/2012	REVISED PER COMMENTS
17	02/01/2012	REVISED PER COMMENTS
18	02/01/2012	REVISED PER COMMENTS
19	02/01/2012	REVISED PER COMMENTS
20	02/01/2012	REVISED PER COMMENTS
21	02/01/2012	REVISED PER COMMENTS
22	02/01/2012	REVISED PER COMMENTS
23	02/01/2012	REVISED PER COMMENTS
24	02/01/2012	REVISED PER COMMENTS
25	02/01/2012	REVISED PER COMMENTS
26	02/01/2012	REVISED PER COMMENTS
27	02/01/2012	REVISED PER COMMENTS
28	02/01/2012	REVISED PER COMMENTS
29	02/01/2012	REVISED PER COMMENTS
30	02/01/2012	REVISED PER COMMENTS
31	02/01/2012	REVISED PER COMMENTS
32	02/01/2012	REVISED PER COMMENTS
33	02/01/2012	REVISED PER COMMENTS
34	02/01/2012	REVISED PER COMMENTS
35	02/01/2012	REVISED PER COMMENTS
36	02/01/2012	REVISED PER COMMENTS
37	02/01/2012	REVISED PER COMMENTS
38	02/01/2012	REVISED PER COMMENTS
39	02/01/2012	REVISED PER COMMENTS
40	02/01/2012	REVISED PER COMMENTS
41	02/01/2012	REVISED PER COMMENTS
42	02/01/2012	REVISED PER COMMENTS
43	02/01/2012	REVISED PER COMMENTS
44	02/01/2012	REVISED PER COMMENTS
45	02/01/2012	REVISED PER COMMENTS
46	02/01/2012	REVISED PER COMMENTS
47	02/01/2012	REVISED PER COMMENTS
48	02/01/2012	REVISED PER COMMENTS
49	02/01/2012	REVISED PER COMMENTS
50	02/01/2012	REVISED PER COMMENTS

Client/Project:
 CITY OF CASPER
 200 NORTH DAVID STREET CASPER, WY 82601
 NORTH PLATTE RIVER RESTORATION
 FIRST STREET REACH
 CASPER, WY 82601

Title:
 100% PLANS
 LANDSCAPING PLAN

Permit-Seed

Project Number: 17262111G
 No. Rev. Date Description





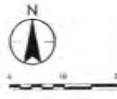
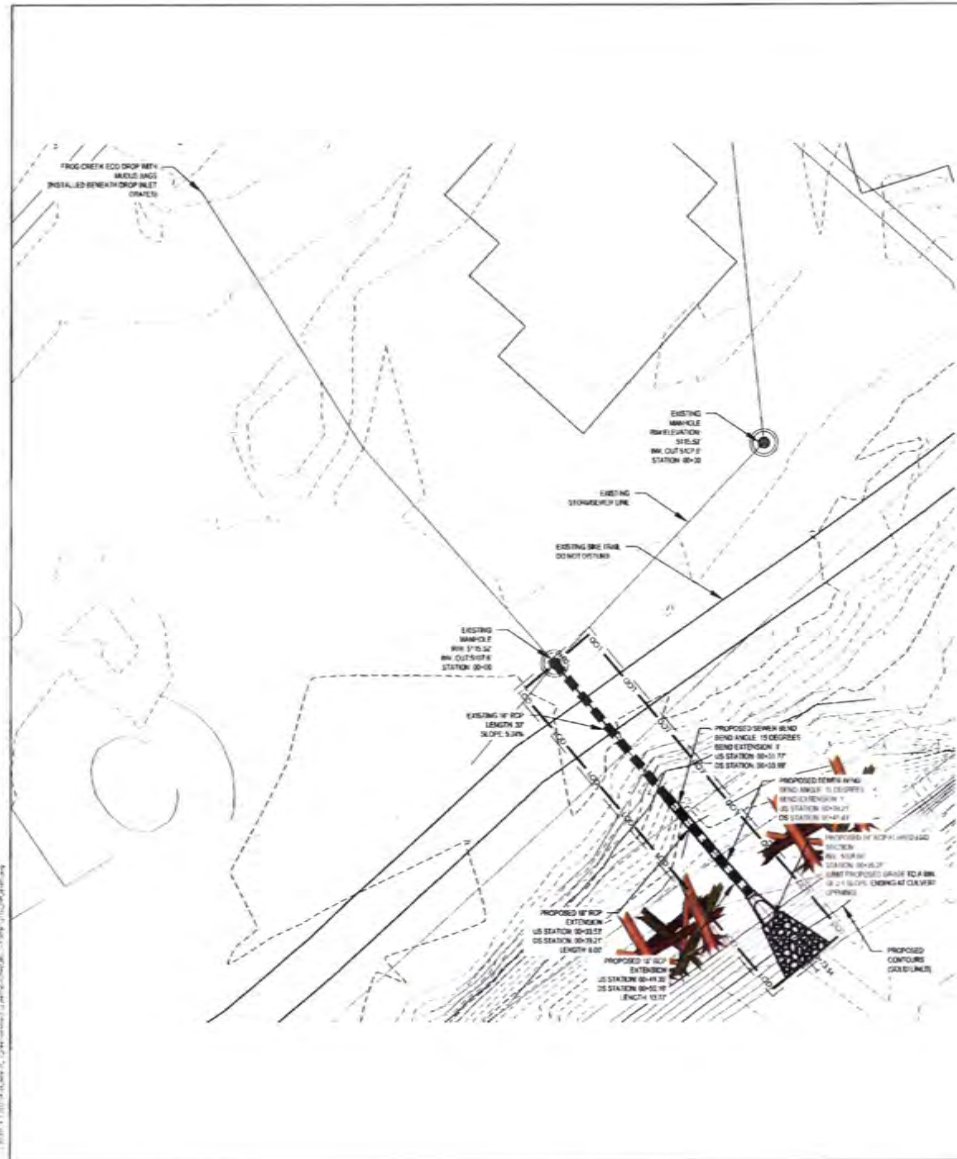

NO.	REV.	DATE	DESCRIPTION
0	1	02/01/2012	ISSUED FOR PERMITS

Drawing No. LANDSCAPING PLAN
 Revision Sheet
 0 1-7



NOTE: SURVEY DATA SHOWN IN DASHED LINES PROVIDED BY THE CITY OF CASPER. ACTUAL ELEVATIONS MAY VARY.

LEGEND

-  PROPOSED SELECT MATERIAL BANK PROTECTION
-  SUPER SILT FENCE
-  LIMITS OF DISTURBANCE
-  EXISTING SANITARY SEWER MANHOLE
-  EXISTING CULVERT (WIDTH MAY VARY)
-  PROPOSED CULVERT (WIDTH MAY VARY)

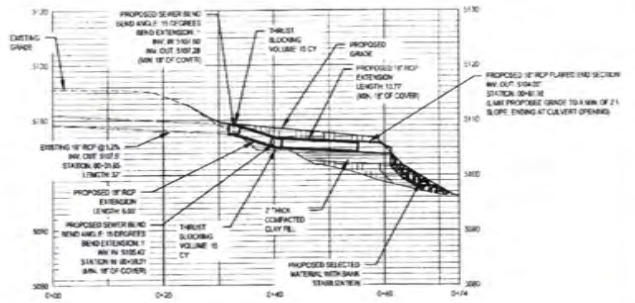

OUTFALL A 0+00 - 0+74

Stantec
 3323 S. Broadway Road, Suite 4100
 Fort Collins, Colorado 80521
 970.226.5000
 www.stantec.com

Revision	Date	By	Check

Client/Project:
 CITY OF CASPER
 200 NORTH DAVID STREET CASPER, WY 82401
 NORTH PLATE RIVER RESTORATION
 FIRST STREET REACH
 CASPER, WYOMING

File:
 100% PLANS
 OUTFALL A

Project Number: 172671193
 Date: 08/16/2016
 Drawing No: 0
 Revision: 15-1

NOTE: SURVEY DATA SHOWN IN DASHED LINES PROVIDED BY THE CITY OF CASPER. GIS DATA SHOWN IN SOLID LINES WAS UTILIZED FROM THE CITY OF CASPER'S GIS WEBSITE. ACTUAL ELEVATIONS MAY VARY.

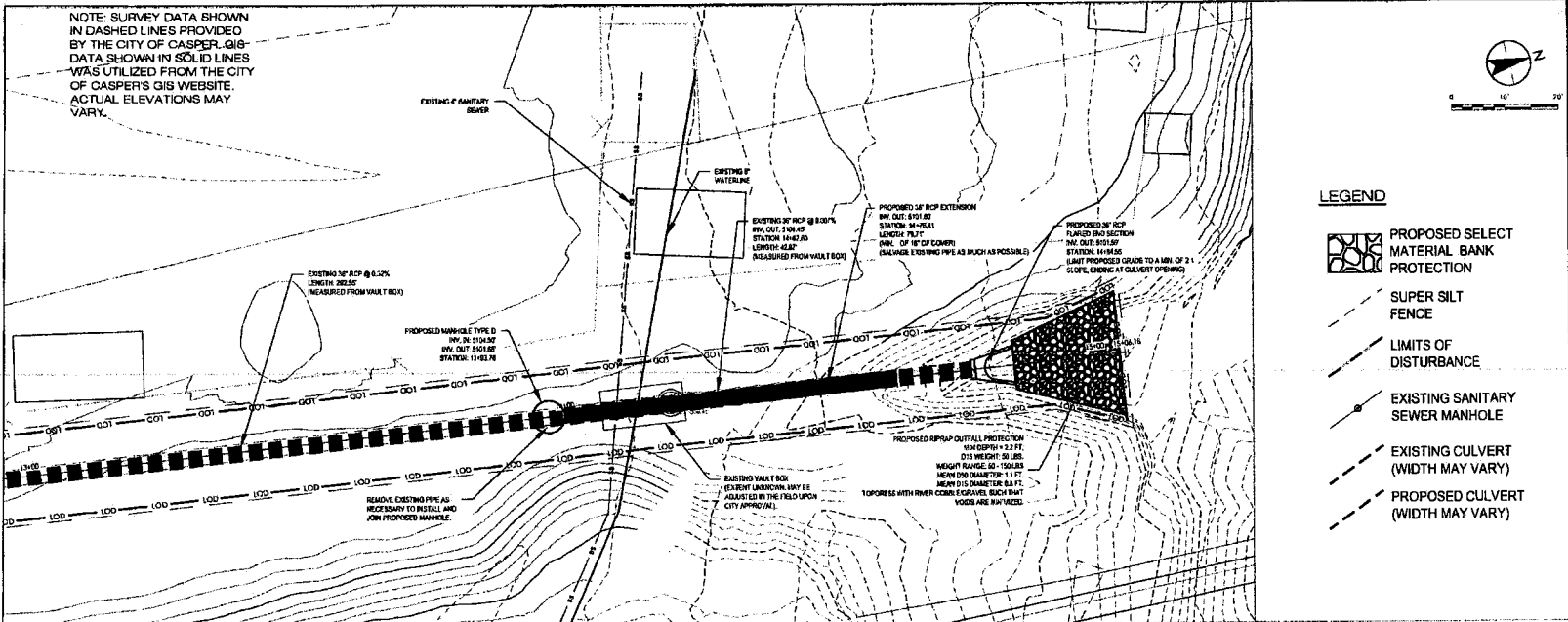

Stantec
 1335 Franklin Road, Suite 113
 Casper, Wyoming 82401
 Phone: 307.234.2000
 Fax: 307.234.2001
 Email: info@stantec.com
 www.stantec.com

NO.	DATE	BY	APP'D	DESCRIPTION
1				ISSUED FOR PERMIT

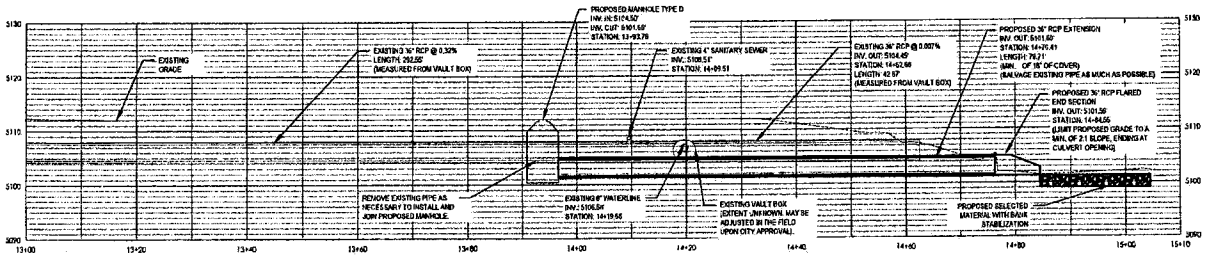

OUTFALL C 13+00 - 15+10

Client/Project
 CITY OF CASPER
 200 NORTH DAVID STREET CASPER, WY 82401

Permit/Spec
 NORTH PLATE RIVER RESTORATION
 FIRST STREET REACH
 CASPER, WYOMING

100% PLANS
 BUSF-STORAWATER LINE-OUTFALL C 2

Project Number: 172621110
 Name: JHS, JMS, RPH, DJS
 Date: 10/20/11
 Drawn: JHS
 Check: JMS
 Date: 11/09/11

Drawing No. _____
 Revision _____
 Sheet _____
 0 55-4



Attachment B

Grantee: Grant #:

Reporting Period: to Submitter Name:

Project Title:

Annual Report

Final Report

Award Amount:

Amount Expended:

Award Balance:

Project Accomplishment(s):

Photos:

PLEASE SUBMIT ANNUAL REPORT WITH PHOTOS BY DECEMBER 31ST EACH YEAR AND FINAL REPORT WITH PHOTOS WITHIN NINETY (90) DAYS OF GRANT/PROJECT COMPLETION TO:

Wyoming Governor's Big Game License Coalition
c/o Wyoming Game and Fish Department - Fiscal Division

Email: wfggrants@wyo.gov

Mail: 5400 Bishop Blvd., Cheyenne, WY 82006

RESOLUTION NO. 20-147

A RESOLUTION AUTHORIZING ACCEPTANCE OF A
GRANT FROM THE WYOMING GOVERNOR'S BIG GAME
LICENSE COALITION

WHEREAS, the City of Casper identified the need to restore the North Platte River through Casper and has established a project called the Platte River Revival; and,

WHEREAS, the City of Casper has been approved for a grant from the Wyoming Governor's Big Game License Coalition 2020 grant cycle, in the amount of Ten Thousand Dollars (\$10,000); and,

WHEREAS, the City of Casper desires to accept the grant funds from the Wyoming Governor's Big Game License Coalition to fund wetland construction and enhancement in the First Street reach of the river restoration project.

NOW, THEREFORE, BE IT RESOLVED BY THE GOVERNING BODY OF THE CITY OF CASPER, WYOMING: That the grant from the Wyoming Governor's Big Game License Coalition, in the amount of Ten Thousand Dollars (\$10,000), is, with gratitude, accepted.

PASSED, APPROVED AND ADOPTED this ____ day of _____, 2019.

APPROVED AS TO FORM:



ATTEST:

CITY OF CASPER, WYOMING
A Municipal Corporation

Fleur D. Tremel
City Clerk

Steven K. Freel
Mayor

June 26, 2020

MEMO TO: J. Carter Napier, City Manager *JCN*

FROM: Keith McPheeters, Chief of Police *KMcP 307*
Lori Jackson, PSCC Manager

SUBJECT: That Council, by Resolution, Authorize an Amendment to the Professional Services Contract with PowerPhone Total Response Emergency Medical Dispatch, in the Total Amount of Seventy-One Thousand, Four Hundred and Ten Dollars and 00/100 (\$71,410.00)

Meeting Type & Date

Regular Council Meeting
July 7, 2020

Action type

Amendment to Professional Services Contract

Recommendation

That Council, by resolution, authorize an amendment to the professional services contract with PowerPhone Total Response Emergency Medical Dispatch, in the total amount of seventy-one thousand, four hundred and ten dollars and 00/100 (\$71,410.00).

Summary

The current Emergency Medical Dispatch (EMD) by Priority Dispatch has been a reliable product that has assisted dispatchers in completing complex medical dispatch. Although the product has been sufficient, the ability to modify the suggested response is not allowed and this does limit our liability coverage provided by the vendor. In order to dispatch effectively and provide a more robust level of care to citizens, the department researched and decided that PowerPhone Total Response Emergency Medical Dispatch Quality Assurance provides an integrated software solution with the Spillman CAD system to ensure a quick and accurate response. The software also provides the Public Safety Communication Center (PSCC) the ability to configure the field unit responses, based on local protocol.

The department has completed webinars and met with the Wyoming Medical Center Director to ensure that we would be provided the guidance to evaluate and modify the Total Response EMD and follow the WMC guidelines for EMD. PowerPhone Total Response Emergency Medical Dispatch allows for modifications by the local medical director to ensure the most efficient and quality care that dispatchers can provide over the phone to the citizen. The agreement between the WMC and Casper/Natrona County PSCC has been lacking for some time and we are able to strengthen the relationship between the two agencies. National guidelines, such as CPR will not be modified, but other protocols that are unique to our area can be modified.

The Spillman and PowerPhone EMD Interface allows for instant EMD when the call nature is matched with the condition. It also records the responses provided by the caller to ensure accuracy and current EMD procedures were followed. The PSCC will be trained by PowerPhone to utilize the system with a train the trainer program which will reduce the overall cost of recertification and training.

Financial Considerations

The initial cost to implement the PowerPhone Total Response EMD QA will be \$71,410 with an annual maintenance of \$6,188. Funding for the initial purchase will come from the remaining funds in the PSCC Reserve Line Item.

Oversight/Project Responsibility

Scott Hoffman, Police Technologies Manager

Lori Jackson, PSCC Manager

Michael Szewczyk, IT Manager

Attachments

Amendment to the Professional Services Contract
Resolution

**AMENDMENT NO. 1 TO THE CONTRACT
FOR PROFESSIONAL SERVICES (“AMENDMENT”)**

This Amendment to the Contract for Professional Services (“Amendment”) is entered into on this 7th day of July, 2020, by and between the following parties:

1. The City of Casper of Casper, Wyoming (“City”), a Wyoming municipal corporation, 200 North David Street, Casper, Wyoming 82601.
2. PowerPhone, Inc. (“Contractor”), 1321 Boston Post Road Madison, Connecticut, 06443.

Throughout this document, the City and the Contractor may be collectively referred to as the “parties.”

RECITALS

A. On June 16, 2020, the City and Contractor entered into a *Contract for Professional Services* (“Contract”) to purchase and install a PowerPhone Total Response Computer Aided Call Handling (CACH).

B. The Contract that was approved by the City attorney was not sent to the Contractor. A previous revision was sent and signed by the Contractor. Upon receipt of the fully executed Contract by the City, the Contractor discovered the error.

C. This Amendment is needed to correct the Contract to properly reflect the intent and agreement of the parties.

NOW, THEREFORE, in consideration of the mutual promises and covenants contained herein, the parties hereto agree by and between them to amend the Contract as follows:

1. INCORPORATION OF RECITALS

The recitals set forth above are hereby incorporated herein at this point as if fully set forth as part of this Amendment.

2. AMENDMENT TO PART I, RECITALS, SECTION D.

Recital D, which begins with “The Contractor will provide a turn-key software system,” is deleted in its entirety and replaced with the following:

The Contractor will provide a turn-key software system that works with the City’s existing computer aided emergency medical dispatch system. The Contractor is not responsible for software outside of the CACH software. The Contractor is not responsible for hardware systems needed to operate the CACH software. The City is aware that a Windows 10 platform is required to install the CACH software.

3. AMENDMENT TO PART I, SECTION 2. TIME OF PERFORMANCE.

Part I, Section 2. Time of Performance, which begins with “The services of the Contractor shall be undertaken,” is deleted in its entirety and replaced with the following:

The services of the Contractor shall be undertaken and completed on or before December 31, 2020.

4. AMENDMENT TO PART I, SECTION 4. METHOD OF PAYMENT.

Part I, Section 4. Method of Payment, which begins with “ Payment will be made,” is deleted in its entirety and replaced with the following:

Buyer shall make progress payments on the basis of the schedule set forth below within thirty (30) days of receipt of an itemized invoice during the term of this Contract. The progress payment schedule shall be as follows: First, upon execution of this Contract, the City shall issue to the Contractor a fifty (50) percent down payment. Second, upon installation of the CACH, the City will issue to the Contractor a forty (40) percent payment. Third, the City shall issue to the Contractor the remaining ten (10) percent payment upon final completion of the performance of services.

If amounts owed by the Contractor to the City for any goods, services, licenses, permits or any other items or purpose remain unpaid beyond the City’s general credit policy, those amounts may be deducted from the payment being made by the City to the Contractor pursuant to this Contract.

5. AMENDMENT TO PART II, SECTION 11. B. 2.

Part II, Section 11. B. 2., which begins with “Automobile Liability: Insurance Office Form Number CA 0001,” is deleted in its entirety and replaced with the following:

Automobile Liability: Intentionally omitted.

6. AMENDMENT TO PART II, SECTION 11. B. 4.

Part II, Section 11. B. 4., which begins with “Professional Liability (Errors and Omissions)” is deleted in its entirety and replaced with the following:

Professional Liability (Errors and Omissions) Insurance: Intentionally omitted.

3. RATIFICATION

The terms and conditions of the Contract, as modified herein, are hereby ratified by the parties and shall remain in full force and effect.

IN WITNESS WHEREOF, the undersigned duly authorized representatives of the Parties have executed this Amendment as of the day and year above.

APPROVED AS TO FORM

Walter Smith

ATTEST

CITY OF CASPER, WYOMING
A Municipal Corporation

Fleur Tremel
City Clerk

Steven K. Freel
Mayor

WITNESS

CONTRACTOR
PowerPhone, Inc.

By: _____

By: _____

Printed Name: _____

Printed Name: _____

Title: _____

Title: _____

RESOLUTION NO. 20-148

A RESOLUTION AUTHORIZING AMENDMENT NO. 1 TO THE PROFESSIONAL SERVICES CONTRACT WITH POWERPHONE, INC. TO PURCHASE AND INSTALL A TOTAL RESPONSE COMPUTER AIDED CALL HANDLING (CACH) SYSTEM.

WHEREAS, on June 16, 2020, the City of Casper and PowerPhone Inc. entered into a *Contract for Professional Services* ("Contract") to purchase and install a PowerPhone Total Response Computer Aided Call Handling (CACH); and,

WHEREAS, the Contract that was approved by the City Attorney was not sent to the Contractor. A previous revision was sent and signed by the Contractor. Upon receipt of the fully executed Contract by the City, the Contractor discovered the error; and,

WHEREAS, an amendment is needed to correct the Contract to properly reflect the intent and agreement of the parties.

NOW, THEREFORE, BE IT RESOLVED BY THE GOVERNING BODY OF THE CITY OF CASPER, WYOMING: That the Mayor is hereby authorized and directed to execute, and the City Clerk to attest, *Amendment No. 1 to the Contract for Professional Services* with PowerPhone Inc.

PASSED, APPROVED, AND ADOPTED on this ___ day of _____, 2020.

APPROVED AS TO FORM:



ATTEST:

CITY OF CASPER, WYOMING
A Municipal Corporation

Fleur Tremel
City Clerk

Steven K. Freel
Mayor

July 1, 2020

MEMO TO: J. Carter Napier, City Manager JW
FROM: Liz Becher, Community Development Director eb
SUBJECT: Authorizing a two (2) Month Contract for Professional Services for the Downtown Parking Garage and Parking Lot Management

Meeting Type & Date:

Regular Council Meeting, July 7, 2020

Action Type:

Resolution.

Recommendation:

That Council, by resolution, approve a two (2) month Contract for Professional Services with the Downtown Development Authority (DDA) for the management operations of the parking garage and the public parking lot at 1st and Center Streets.

Summary:

The current parking management contract between the City of Casper and the DDA expired on June 30, 2020. The proposed contract would extend the management of the downtown parking facilities for two (2) months while Council considers the proposals received in response to the recent Request for Proposal (RFP) for parking facility management for a new four (4) year term.

Financial Consideration:

None.

Oversight/Project Responsibility:

Liz Becher, Community Development, is tasked with overseeing the Parking Garage.

Attachments:

Contract for Professional Services
Resolution

CONTRACT FOR PROFESSIONAL SERVICES

PART I - AGREEMENT

This Contract for Professional Services ("Contract") is entered into on this 3rd day of July, 2020 by and between the following parties:

1. The City of Casper, Wyoming, a Wyoming municipal corporation, 200 North David Street, Casper, Wyoming 82601 ("City").
2. The Downtown Development Authority ("Contractor"), 341 Yellowstone Highway, Casper, Wyoming 82601.

Throughout this document, the City and the Contractor may be collectively referred to as the "parties."

RECITALS

A. The City is seeking professional services related to the management of the Municipal Parking Structure located at 230 South Wolcott Street, hereinafter known as the "Facility" and the Municipal Parking Lot located at 106 South Center Street, hereinafter known as "Parking Lot No. 1;" and,

B. The City desires to retain the Contractor to perform certain services related to management of the Facility and Parking Lot No. 1, and the Contractor represents that it is ready, willing, and able to provide the professional services to the City as required by this Contract.

NOW, THEREFORE, in consideration of the covenants and conditions set forth herein to be performed, the parties agree as follows:

1. SCOPE OF SERVICES:

The Contractor shall perform the following services in connection with and respecting the Contract, as follows:

- A. Operate the Facility and Parking Lot No. 1 so that the general public will have access to parking spaces under the condition of payment of fees and compliance with regulations established by the Contractor.
- B. Establish and collect all fees for parking in the Facility. These include hourly parking, monthly parking, and handicapped parking. The fees will be collected and reported to the Business Services Section of the Finance Division on a monthly basis.
- C. Conduct bi-weekly counts of the actual number of vehicles in the Facility. One (1)

peak time, one (1) early morning, and one (1) Saturday time shall be selected. These three (3) counts shall be taken at the same date/time every other week to facilitate an assessment of actual use over time.

- D. Establish and collect all fees for monthly parking at Parking Lot No. 1, including a provision in the monthly leases addressing hours of open public parking. The fees will be collected and reported to the Business Services Section of the Finance Division on a monthly basis. Any changes to the fee schedule shall be reported in the monthly report.
- E. Provide daily maintenance of the Facility to include, but not be limited to: the change-out of light bulbs; litter clean up; cleaning of the stairwells, office spaces and elevators; cleaning of windows; touch-up painting; repair of vandalism; maintenance of all landscaping; and, sweeping of the Facility. The City shall be responsible for graffiti removal.
- F. Provide for snow removal of the uncovered spaces in the Facility, and for Parking Lot No. 1 with equipment provided by the City.
- G. Provide for regular maintenance of Parking Lot No. 1 to include, but not be limited to: Litter clean-up; sweeping; repairs of vandalism. The City shall be responsible for graffiti removal.
- H. Handle all complaints from users of the Facility and Parking Lot No. 1, including, but not limited to: disputes involving charges for parking; space assignments; concerns about persons engaged in inappropriate activities, vandalism of private vehicles, and restroom maintenance. The Contractor shall provide signs with numbers to call for comments/complaints at each entrance, the exit, and in each stairwell.
- I. Pay the appropriate utility bills for services related directly to the management of the Facility, to include water, sewer, internet/telephone, and electricity.
- J. Establish regulations for users of the Facility and Parking Lot No.1, including hours of operation; conditions of monthly lease agreements; restrictions on parking in particular spaces; and, penalties for late payments. Notify all users of regulations, install appropriate signage for hourly customers, and publish/post the regulations on the Contractor's website and have a printed copy of the regulations available at the Contractor's office. The rules and regulations shall be posted in the stairwells of the Facility. The Contractor shall provide the Community Development Director with a copy of the regulations within ninety (90) days of the execution of the Contract.
- K. Provide a copy of the Facility Marketing Plan to the Community Development Director within ninety (90) days of the execution of this Contract.

- L. Provide an annual report to the Assistant to the City Manager no later than August 15th of each year. The annual report shall include a financial statement, review of the use of the Facility, and a summary of the most frequent comments/complaints. The revenue and expenses for the Facility and Parking Lot No. 1 shall be reported separately. The annual report shall include recommendations for minor and major repairs/replacements or upgrades.
- M. Pay to the Business Services Section of the Finance Division an agreed upon amount for depreciation expense of THREE HUNDRED SIXTY-THREE DOLLARS (\$363.00) per month.

The City shall:

- A. Maintain general comprehensive insurance on the structure against damage as a results of fires, earthquakes, or other disasters.
- B. Pay the maintenance contract for servicing the elevators in the Facility. The Buildings and Structures Superintendent shall be responsible for the scheduling of any required repairs to the elevators. Repairs shall only be made during the hours of 7:00 AM to 7:00 PM, Monday through Friday.
- C. Provide for daily maintenance of the restrooms including cleaning and stocking supplies. The City shall inspect the restrooms at least three (3) times per day and set the hours the restrooms will be open.
- D. Make all necessary repairs to the Facility and Parking Lot No.1 including, but not limited to: elevator equipment, utility systems, concrete and asphalt surfaces, repair and replacement of signs, and wheel stops.
- E. Be responsible for the provision, maintenance, repair and replacement of all furniture, ballasts, and equipment necessary for the collection of fees.
- F. Provide supplies to support the office and maintenance responsibilities, including, but not limited to: tickets, light bulbs, forms, paper, pens, cleaning supplies and tools.
- G. Permit the Contractor to use a 4-wheeler and sweeper for security, and Facility and Parking Lot No.1 maintenance. The Fleet Maintenance Manager shall provide the required remedial and preventative maintenance and Contractor shall provide fuel, oil, and daily maintenance. The Contractor shall make any requests for equipment upgrades, replacements or additions to the Community Development Director in writing. The Contractor is responsible for any damage to the equipment not caused through normal wear and tear.

2. TIME OF PERFORMANCE:

The services of the Contractor shall be for two (2) months, beginning July 1, 2020, and ending on August 31, 2020.

3. PROFIT SHARING PROVISION:

In consideration of the performance of services rendered under this Contract, the Contractor shall calculate annual gross income from revenues collected for parking fees and other income generated as a result of the operation of the Facility and Parking Lot No. 1. The net income shall be calculated by deducting all of the direct expenses related to operation of the Facility and Parking Lot No. 1, and the amount paid to the City for depreciation expense, as provided in Section 1, from the gross income. A report providing detailed information on revenues and expenses will be provided to the Finance Director prior to the fifteenth day of August in each year that the contract is in effect. After the net income figures have been calculated and verified, the Contractor shall pay an amount to the Business Services Section of the Finance Division on a sliding scale as follows, which is in addition to the depreciation expense as provided for in Section 1:

Zero (\$0) to Twenty Thousand Dollars (\$20,000) of net income = Ten Percent (10%)

Twenty Thousand Dollars (\$20,000) to Thirty Thousand Dollars (\$30,000) of net income = Fifteen Percent (15%)

Thirty Thousand Dollars (\$30,000) to Forty Thousand Dollars (\$40,000) of net income = Twenty Percent (20%)

Forty Thousand Dollars (\$40,000) and above of net income = Twenty Percent (20%).

4. TERMS AND CONDITIONS:

This Contract is subject to and incorporates the provisions attached hereto as PART II -- GENERAL TERMS AND CONDITIONS.

5. EXTENT OF CONTRACT:

This Contract represents the entire and integrated Agreement between the City and the Contractor, and supersedes all prior negotiations, representations, or agreements, either written or oral. The Contract may be amended only by written instrument signed by both the City's and the Contractor's authorized representatives.

The City and the Contractor each individually represent that they have the requisite authority to execute this Contract and perform the services described in this Contract.

IN WITNESS WHEREOF, the undersigned duly authorized representatives of the parties have executed this Contract as of the day and year above.

APPROVED AS TO FORM

Wallie Tremel

ATTEST

CITY OF CASPER, WYOMING
A Municipal Corporation

Fleur Tremel
City Clerk

Steven K. Freel
Mayor

WITNESS

CONTRACTOR

By: Liz Becher
Printed Name: Liz Becher
Title: Community Development Director

By: Tim Schenk
Printed Name: TIM SCHENK
Title: DDA BOARD CHAIRMAN

CONTRACT FOR PROFESSIONAL SERVICES

PART II - GENERAL TERMS AND CONDITIONS

1. TERMINATION OF CONTRACT:

1.1 The City may terminate this Contract anytime by providing thirty (30) days written notice to Contractor of intent to terminate said Contract. In such event, all finished or unfinished documents, data, studies and reports prepared by the Contractor under this Contract shall, at the option of the City, become its property, and the Contractor shall be entitled to receive just and equitable compensation for any satisfactory work completed on such documents.

1.2 Notwithstanding the above, the Contractor shall not be relieved of liability to the City for damages sustained by the City, by virtue of termination of the Contract by Contractor, or any breach of the Contract by the Contractor, and the City may withhold any payments to the Contractor for the purpose of setoff until such time as the exact amount of damages due the City from the Contractor are determined.

2. CHANGES:

The City may, from time to time, request changes in the scope of the services of the Contract. Such changes, including any increase or decrease in the amount of the Contractor's compensation, which are mutually agreed upon between the City and the Contractor, shall be incorporated in written amendments to this Contract. There shall be no increase in the amount of Contractor's compensation unless approved by Resolution adopted by City.

3. ASSIGNABILITY:

The Contractor shall not assign any interest in this Contract, and shall not transfer any interest in the same (whether by assignment or novation) without the prior written approval of the City: provided, however, that claims for money due or to become due the Contractor from the City under this Contract may be assigned to a bank, trust company, or other financial institution, or to a trustee in bankruptcy, without such approval. Notice of any assignment or transfer shall be furnished to the City within five (5) business days of any assignment or transfer.

4. AUDIT:

The City or any of its duly authorized representatives shall have access to any books, documents, papers, and records of the Contractor which are directly pertinent to the Contract for the purpose of making audit, examination, excerpts, and transactions.

5. EQUAL EMPLOYMENT OPPORTUNITY:

In carrying out the program, the Contractor shall not discriminate against any employee or applicant for employment because of race, color, religion, sex, national origin, or disability. The Contractor shall take affirmative action to ensure that applicants for employment are employed, and that employees are treated during employment, without regard to their race, color, religion, sex, national origin, or disability. Such action shall include, but not be limited to, the following: employment upgrading, demotion, or transfer; recruitment or recruitment advertising; layoff or termination; rates of pay or other forms of compensation; and selection for training, including apprenticeship. The Contractor shall post in conspicuous places, available to employees and applicants for employment, notices required by the government setting forth the provisions of this nondiscrimination clause. The Contractor shall state that all qualified applicants will receive consideration for employment without regard to race, color, religion, sex, national origin, or disability.

6. OWNER OF PROJECT MATERIALS:

All finished or unfinished documents, data, studies, surveys, drawings, maps, models, photographs, films, duplicating plates, and reports prepared by the Contractor under this Contract shall be considered the property of the City, and upon completion of the services to be performed, they will be turned over to the City provided that, in any case, the Contractor may, at no additional expense to the City, make and retain such additional copies thereof as Contractor desires for its own use; and provided further, that in no event may any of the documents, data, studies, surveys, drawings, maps, models, photographs, films, duplicating plates, or other reports retained by the Contractor be released to any person, agency, corporation, or organization without the written consent of the City.

7. FINDINGS CONFIDENTIAL:

All reports, information, data, etc., given to or prepared, or assembled by the Contractor under this Contract are confidential and shall not be made available to any individual or organization by the Contractor without the prior written consent of the City.

8. GOVERNING LAW:

This Contract shall be governed by the laws of the State of Wyoming. The Contractor shall also comply with all applicable laws, ordinances, and codes of the local, state, or federal governments and shall not trespass on any public or private property in performing any of the work embraced by this Contract.

9. PERSONNEL:

The Contractor represents that it has, or will secure, all personnel required in performing the services under this Contract. Such personnel shall not be employees of the City. All

of the services required shall be performed by the Contractor, or under its supervision, and all personnel engaged in the work shall be fully qualified. All personnel employed by Contractor shall be employed in conformity with applicable local, state or federal laws.

10. SUBCONTRACTOR:

The Contractor shall not employ any subcontractor to perform any services in the scope of this project, unless the subcontractor is approved in writing by the City. Any approved subcontractor shall be paid by the Contractor.

11. INSURANCE AND INDEMNIFICATION:

A. **Prior to** the commencement of work, Contractor shall procure and maintain for the duration of the contract insurance against claims for injuries to persons or damages to property which may arise from or in connection with the performance of the work hereunder by the Contractor, its subcontractors, agents, representatives, or employees.

B. *Minimum Scope and limit of Insurance.*

Coverage shall be at least as broad as:

1. Commercial General Liability (CGL): Insurance Services Office Form CG 00 01 covering CGL on an "occurrence" basis, including products and completed operations, property damage, bodily injury and personal & advertising injury with limits no less than the sum of Two Hundred Fifty Thousand Dollars (\$250,000) to any claimant for any number of claims arising out of a single transaction or occurrence; or the sum of Five Hundred Thousand Dollars (\$500,000) for all claims arising out of a single transaction or occurrence. If a general aggregate limit applies, the general aggregate limit shall apply separately to this project/location. The CGL policy shall be endorsed to contain Employers Liability/Stop Gap Coverage
2. Automobile Liability: Insurance Services Office Form Number CA 0001 covering, Code 1 (any auto), or if Contractor has no owned autos, Code 8 (hired) and 9 (non-owned), with limit no less than Five Hundred Thousand (\$500,000) per accident for bodily injury and property damage.
3. Workers' Compensation: as required by the State of Wyoming with Statutory Limits.
4. Professional Liability (Errors and Omissions) Insurance appropriate to the Contractor's profession, with limit no less than the sum of Two Hundred Fifty Thousand Dollars (\$250,000) to any claimant for any number of claims arising out of a single transaction or occurrence; or the sum of Five Hundred Thousand Dollars (\$500,000) for all claims arising out of a single transaction or occurrence. If a general aggregate limit applies, the general aggregate limit shall apply separately to this project/location.

C. *Higher Limits.* If the Contractor maintains higher limits than required under this Agreement, then the City shall be entitled to coverage for the higher limits maintained by the Contractor. Any available insurance proceeds in excess of the specified minimum limits of insurance and coverage shall be available to the City.

D. *Other Insurance Provisions*

The insurance policies are to contain, or be endorsed to contain, the following provisions:

1. *Additional Insured Status*

The City, its officers, elected and appointed officials, employees, agents and volunteers are to be covered as additional insureds on the CGL policy with respect to liability arising out of work or operations performed by or on behalf of the Contractor including materials, parts, or equipment furnished in connection with such work or operations. General liability coverage shall be provided in the form of an endorsement to the Contractor's insurance (at least as broad as ISO Form CG 20 10 11 85 or both CG 20 10 and CG 20 37 forms if later revisions used).

2. *Primary Coverage*

For any claims related to this contract, the Contractor's insurance coverage shall be primary and non-contributory insurance as respects the City, its officers, elected and appointed officials, employees, agents and volunteers.

3. *Notice of Cancellation*

Each insurance policy required above shall state that coverage shall not be canceled, materially changed, or reduced, except with notice to the City. Such notice to the City shall be provided in a commercially reasonable time.

4. *Waiver of Subrogation*

Contractor hereby grants to City a waiver of any right to subrogation which any insurer of said Contractor may acquire against the City by virtue of the payment of any loss under such insurance. Contractor agrees to obtain any endorsement that may be necessary to affect this waiver of subrogation, but this provision applies regardless of whether or not the City has received a waiver of subrogation endorsement from the insurer.

5. *Deductibles and Self-Insured Retentions*

Contractor has two options regarding deductibles and self-insured retentions:

- a. Option 1: Any deductibles or self-insured retentions must be declared to and approved by the City. Unless otherwise approved by the City in writing, any deductible may not exceed Ten Thousand Dollars (\$10,000). Unless otherwise approved in writing by the City, self-insured retentions may not

exceed Ten Thousand Dollars (\$10,000), and the City may require the Contractor to provide proof of ability to pay losses and related investigations, claim administration, and defense expenses within the retention.

- b. Option 2: Contractor shall carry insurance with terms that require its insurance company to pay the full value of a covered claim from the first dollar of coverage, even if the Contractor is unable to pay any deductible or self-insured retention amount(s) required by the insurance policy. Contractor shall provide a written endorsement from its insurance carrier that such insurance coverage is in place, and shall keep such coverage in place during the term of this Contract and any subsequent time period required for claims made policies.

6. *Acceptability of Insurers*

Insurance is to be placed with insurers with a current A.M. Best's rating of no less than A:VII, unless otherwise agreed to in writing by the City.

7. *Claims Made Policies*

If any of the required policies provide coverage on a claims-made basis:

- a. The Retroactive Date must be shown and must be before the date of the contract or the beginning of contract work.
- b. Insurance must be maintained and evidence of insurance must be provided *for at least three (3) years after completion of the contract of work*. However, Contractor's liabilities under this Contract shall not be deemed limited in any way by the insurance coverage required.
- c. If coverage is canceled or non-renewed, and not *replaced with another claims-made policy form with a Retroactive Date* prior to the contract effective date, the Contractor must purchase "extended reporting" coverage for a minimum of *three (3) years* after completion of contract work and at all times thereafter until the applicable statute of limitations runs.

8. *Verification of Coverage*

Contractor shall furnish the City with original certificates and amendatory endorsements or copies of the applicable policy language effecting coverage required by this clause. All certificates and endorsements are to be received and approved by the City before work commences. However, failure to obtain the required documents prior to the work beginning shall not waive the Contractor's obligation to provide them. The City reserves the right to require complete, certified copies of all required insurance policies, including endorsements required by these specifications, at any time.

9. *Subcontractors*

Contractor shall require and verify that all subcontractors maintain insurance meeting all the requirements stated herein, and Contractor shall ensure that the City is an additional insured on insurance required from subcontractors.

10. *Special Risks or Circumstances*

City reserves the right to reasonably modify these requirements, including limits, based on the nature of the risk, prior experience, insurer, coverage, or other special circumstances.

E. Contractor agrees to indemnify the City, the City's employees, elected officials, appointed officials, agents, and volunteers, and all additional insured and hold them harmless from all liability for damages to property or injury to or death to persons, including all reasonable costs, expenses, and attorney's fees incurred related thereto, to the extent arising from negligence, fault or willful and wanton conduct of the Contractor and any subcontractor thereof.

12. INTENT:

Contractor represents that it has read and agrees to the terms of this Contract and further agrees that it is the intent of the parties that Contractor shall perform all of the services for the compensation set forth in this Contract. Contractor also agrees that it is the specific intent of the parties, and a material condition of this Contract, that it shall not be entitled to compensation for other services rendered unless specifically authorized by the City by Resolution of its governing body. Contractor agrees that it has carefully examined the Scope of Services, and that the compensation is adequate for performance of this Contract.

13. WYOMING GOVERNMENTAL CLAIMS ACT:

The City does not waive any right or rights it may have pursuant to the Wyoming Governmental Claims Act, Wyoming Statutes Section 1-39-101 *et seq.*, and the City specifically reserves the right to assert any and all rights, immunities, and defenses it may have pursuant to the Wyoming Governmental Claims Act.

14. NO THIRD PARTY BENEFICIARY RIGHTS:

The parties to this Contract do not intend to create in any other individual or entity the status of third-party beneficiary, and this Contract shall not be construed so as to create such status. The rights, duties and obligations contained in this Contract shall operate only between the parties to this Contract, and shall inure solely to the benefit of the parties to this Contract. The parties to this Contract intend and expressly agree that only parties signatory to this Contract shall have any legal or equitable right to seek to enforce this Contract, to seek any remedy arising out of a party's performance or failure to perform any term or condition of this Contract, or to bring an action for the breach of this Contract.

RESOLUTION NO. 20-149

A RESOLUTION APPROVING A CONTRACT FOR PROFESSIONAL SERVICES WITH THE DOWNTOWN DEVELOPMENT AUTHORITY FOR THE OPERATION AND MANAGEMENT OF THE MUNICIPAL PARKING STRUCTURE AND PARKING LOT NO. 1 AT 1ST AND CENTER STREETS.

WHEREAS, the City of Casper is the owner of the Municipal Parking Structure at 230 South Wolcott Street and Parking Lot No. 1 at 106 South Center Street; and,

WHEREAS, the City of Casper is seeking a contractor to operate/manage the Municipal Parking Structure and Parking Lot No. 1 for the next two (2) months while it completes the discussion regarding the responses to the Request for Proposals (RFP) for the future management of the downtown parking facilities; and,

WHEREAS, the Downtown Development Authority (DDA) has represented that is willing and able to continue to operate/manage the downtown parking facilities; and,

WHEREAS, the City of Casper desires to enter into a Contract for Professional Services with the DDA to operate/manage the Municipal Parking Structure and Parking Lot No. 1.

NOW, THEREFORE, BE IT RESOLVED BY THE GOVERNING BODY OF THE CITY OF CASPER, WYOMING: That the Mayor is hereby authorized and directed to approve, and the City Clerk to attest, a Contract for Professional Services with the Downtown Development Authority to operate/manage the Municipal Parking Structure and Parking Lot No.1, beginning July 1, 2020, and ending on August 31, 2020.

PASSED, APPROVED, AND ADOPTED on this ____ day of _____, 2020.

APPROVED AS TO FORM:



ATTEST:

Fleur Tremel
City Clerk

CITY OF CASPER, WYOMING
A Municipal Corporation

Steven K. Freel
Mayor

June 30, 2020

MEMO TO: J. Carter Napier, City Manager 
FROM: Fleur Tremel, Assistant to the City Manager/City Clerk
Carla Mills-Laatsch, Licensing Specialist

SUBJECT: Authorize use of a Patio for Restaurant Liquor License No. 44, Located at 303 South Wolcott Street.

Meeting Type & Date
Regular Council Meeting
July 7th, 2020

Action type
Minute Action

Recommendation
That Council, by minute action, authorize use of a patio for restaurant liquor license no. 44, for Occasions by Cory, LLC, d/b/a Occasions Entertainment Group, located at 303 South Wolcott Street.

Summary
A request has been received for the use of a patio from restaurant liquor license, no. 44, for Occasions by Cory, LLC, d/b/a Occasions Entertainment Group, located at 303 South Wolcott Street.

City Staff received a request from the owner of Occasions by Cory, LLC., to serve alcoholic beverages in conjunction with a meal on their patio. Municipal code 5.080.350 (B) states that alcoholic beverages may be served in an adjacent fenced or enclosed area as approved by the City Council. The patio is 21' x 25' and is located on the south east side of the building in the back parking lot.

Financial Considerations
N/A

Oversight/Project Responsibility
Carla Mills-Laatsch, Licensing Specialist

Attachments
Letter from Occasions by Cory

OCCASIONS
ENTERTAINMENT
GROUP
EATERY & SPECIAL EVENT VENUE

To Whom it May Concern:

Please accept this letter as my request to serve alcohol on my patio in compliance with my liquor license located at Occasions Entertainment Group at 303 S. Wolcott Street. The patio has been recently completed and has met all City codes.

Thank you for your assistance.

Best Regards,
Cory Poulos – President
Occasions by Cory + Occasions Entertainment Group
303 S. Wolcott Street
Casper, WY 82601
307.337.CORY